



**INSTITUTO DE CIENCIAS  
DE LA CONSTRUCCIÓN  
EDUARDO TORROJA**

C/ Serrano Galvache 4. 28033 Madrid (Spain)  
Tel: (+34) 91 302 0440. [www.ietcc.csic.es](http://www.ietcc.csic.es)  
[gestiondit@ietcc.csic.es](mailto:gestiondit@ietcc.csic.es) [dit.ietcc.csic.es](http://dit.ietcc.csic.es)



Member of  
[www.eota.eu](http://www.eota.eu)

## European Technical Assessment

**ETA 23/0875  
of 08/02/2023**

English translation prepared by IETcc. Original version in Spanish language

### General Part

**Technical Assessment Body issuing the European Technical Assessment:**

Instituto de Ciencias de la Construcción Eduardo Torroja (IETcc)

**Trade name of the construction product**

GRAPAMAR PF 1011

**Product family to which the construction product belongs**

Kit composed by subframe and fixings for fastening cladding and external wall elements

**Manufacturer**

ANCLAJES GRAPAMAR S.L.  
Ctra Novelda-Aspe Km 1  
03660 NOVELDA (Alicante) Spain  
Tlf.: (+34) 965 607 016  
[www.grapamar.com](http://www.grapamar.com)

**Manufacturing plant(s)**

ANCLAJES GRAPAMAR S.L.  
Ctra Novelda-Aspe Km 1  
03660 NOVELDA (Alicante) España  
Tlf.: (+34) 965 607 016  
[www.grapamar.com](http://www.grapamar.com)

**This European Technical Assessment contains**

22 pages including 3 Annexes, which form an integral part of this assessment. Annex C contains confidential information and is not included in the ETA when is publicly available

**This European Technical Assessment is issued in accordance with Regulation (EU) No 305/2011, on the basis of**

European Assessment Document (EAD)  
090034-00-0404. Ed. June 2016  
Kit composed by subframe and fixings for fastening cladding and external wall elements

Translations of this European Technical Assessment in other languages shall fully correspond to the original issued document and should be identified as such.

Communication of this European Technical Assessment, including transmission by electronic means, shall be in full (excepted the confidential Annex(es) referred to above). However, partial reproduction may be made, with the written consent of the issuing Technical Assessment Body. Any partial reproduction has to be identified as such.



## SPECIFIC PART

### 1. Technical description of the product

The assessed kits, composed by subframe and fixings for fastening skin elements “GRAPAMAR PF 1011” are classified as type 2a –punctual hidden fixing on vertical profile (PF 1011 OCULTO) and type 3a – punctual visible fixing on vertical profile (PF 1011 VISTO) according to the EAD 090034-00-0404: *Kit composed by subframe and fixings for fastening cladding and external wall elements*, edition June 2016 (hereinafter EAD 090034-00-0404).

The kits are made of components mechanically assembled and the skin elements are also mechanically fixed. Adhesive is used exclusively as ancillary component, being its contribution to the mechanical resistance of the kits ignored (mechanical characteristics of the components are tested without adhesive). The kits components are defined in table 1; they are factory produced by the ETA holder or a supplier.

TABLE 1 – DEFINITION OF THE KIT COMPONENTS					
Components		Material		Sizes [mm]	
Skin element fixings <sup>(1)</sup>	Elements <sup>(2)</sup> used to secure skin elements to the subframe	PF 1011 OCULTO Punctual hidden fixing	Extruded aluminium 6063-T6	fixing holder plate	See figure 6-A
			Stainless steel AISI 301 (1.4310)	retainer	
		PF 1011 VISTO Punctual visible fixing	Extruded aluminium 6063-T6	fixing holder plate	See figure 6-B
			Stainless steel AISI 301 (1.4310)	strip retainer	
Subframe	Vertical profiles <sup>(3)</sup> used to transfer loading from fixings into brackets	Extruded aluminium 6063-T6		“C” fluted 45 x 30 x 2.5 (figure 5-A) “C” flat 45 x 30 x 2.5 (figure 5-B)	
	Brackets <sup>(4)</sup> used to transfer loading from vertical profiles into substrate	Extruded aluminium 6063-T6		See Annex A and figures 2 and 3	
Fasteners	Fasteners between brackets and vertical profile	Self-drilling screw with EPDM washer Stainless steel A2		Ø 6.3 L=25	
	Fasteners between vertical profile and fixings	Self-drilling screw Stainless steel A2		Ø 4.8 L=16	
Auxiliary components	Adhesive	Polyurethane resin		See Annex B	
	Anchorage to substrate	-			

### 2. Specification of the intended use in accordance with the applicable EAD

#### 2.1 Intended use

“GRAPAMAR PF 1011” kits are intended to be used for mechanical fastening of skin elements in façade with air space, ventilated or not, and to be anchored to supporting structures in new or existing buildings, as defined in Cl. 1.3.4 of the EAD 090034-00-0404, where is usually fixed an insulation material defined in accordance with an EN standard or an ETA.

The subframe and fixing kit is non-load-bearing construction system. It does not contribute to the stability of the wall on which is installed, neither to ensure the air tightness of the building structure.

#### 2.2 Relevant general conditions for the use of the kit

The provisions made in this European Technical Assessment, according to the EAD, are based on an assumed working life of 25 years as minimum when installed in the works, provided that the conditions lay down for the installation, packaging, transport and storage as well as appropriate use, maintenance and repair are met. These provisions are based upon the current state of the art and the available knowledge and experience.

(1) Manufactured by ANCLAJES GRAPAMAR S.L.  
 (2) See Annex A (Fixings and subframe specifications)  
 (3) Not manufactured by ANCLAJES GRAPAMAR S.L.  
 (4) Manufactured by ANCLAJES GRAPAMAR S.L.



The indications given on the working life cannot be interpreted as a guarantee neither given by the product manufacturer or his representative nor by EOTA when drafting the EAD nor by IETcc issuing this ETA, but are regarded only as a means for expressing the expected economically reasonable working life of the product.

### 2.3 Design of kit

The design of subframe and fixing kits for fastening cladding and external wall elements using “GRAPAMAR PF 1011” kits should take into account:

- The substrate material to define the suitable anchorages, assuming that the substrate meets the mechanical requirements (resistance to static and dynamic actions) and ensures airtightness, watertightness and water vapour permeability.
- The mechanical characteristic values of the kit components (e.g. cladding elements, cladding fixings and subframe) in order to resist the actions (dead loads, wind loads, etc.) applying on the specific work. National safety factor must be used.
- The possible movements of the substrate and the position of the building expansion joints.
- The dilation of the kit components and of the plates.
- The category of corrosivity of the atmosphere of the works <sup>(5)</sup>.
- Because joints are not watertight, materials with low water absorption must compose the first layer behind ventilated air space.
- Insulation layer, usually fixed on the external wall should be defined in accordance with a harmonized standard or a European technical assessment.
- The construction of façade specific parts (e.g. base, top, corners, windows etc.)
- If the entire building must comply with the specific building regulations, particularly concerning fire and wind-load resistances of the Member State where the work is to be built.

### 2.4 Installation of kit in works

Installation should be carried out according to the ETA holder’s specifications and using the specific kit components, manufactured by the ETA holder or by suppliers recognized by the ETA holder. Installation should be carried out by appropriately qualified staff and under the supervision of the technical responsible of the site.

### 2.5 Use, maintenance and repair of the works

Maintenance of the assembled systems or kit components includes inspections on site, taking into account the following aspects:

- Regarding the cladding elements appearance of any damage such as cracking or detachment due to permanent and irreversible deformation.
- Regarding metallic components: presence of corrosion or water accumulation.

Necessary repairs should be done rapidly, using the same kit components and following the repair instructions given by ETA holder.

## 3. Performance of the product and references to the methods used for its assessment.

The assessment of “GRAPAMAR PF 1011” kits according to the Basic Works Requirements (BWR) was carried out in compliance with the EAD 090034-00-0404. The characteristics of the components shall correspond to the respective values laid down in the technical documentation of this ETA, checked by IETcc.

In table 2 a summary of “GRAPAMAR PF 1011” kits performance.

(5) (E.g. see table 1 of Standard EN ISO 12944-2: 2017. Paints and varnishes. Corrosion protection of steel structures by protective paint systems. Part 2: Classification of environments.



TABLE 2 – SUMMARY OF “GRAPAMAR PF 1011” KITS PERFORMANCE					
Basic Works Requirement	Nº	Essential characteristic	ETA section	Performance	
BWR 2 Safety in case of fire	1	Reaction to fire	3.1	See § 3.1	
BWR 4 Safety and accessibility in use	2	Wind load resistance	3.2	PF 1011 OCULTO	2.4 kPa
				PF 1011 VISTO	3.6 kPa
	3	Resistance to vertical load of the whole assembled system	-	Not assessed	
	4	Resist. to vertical load of the skin element fixings	3.3	See § 3.3	
	5	Resist. to horiz. load of the skin element fixings	3.4	See § 3.4	
	6	Resist. to pulsating load of skin element fixings	-	Not assessed	
	7	Resist. of skin element fixings in case of inaccuracies of installation	-	Not relevant for GRAPAMAR PF1011 type of fixing	
	8	Pull-through resistance of fixings from profile	-		
	9	Pull-out resistance of fixings from profile	-		
	10	Inertia and resistance of profiles	3.5	See § 3.5 and annex A	
	11	Resistance to vertical load of brackets	3.6	See § 3.6	
	12	Resistance to horizontal load of brackets	3.7	See § 3.7	
	13	Mechanical characteristics of subframe fixings	3.8	See § 3.8 and annex A	
	14	Corrosion	3.9	See § 3.9	

### 3.1 Reaction to fire – BWR 2

The complete subframe and fixing kit is made only of metal with any combustible ancillary component(s) which fulfils the requirements for small components as set out in Cl.M.1 of Annex M of the EAD. In this case the contribution to fire of these component(s) in question can be neglected and therefore doesn't need to be tested.

Consequently, the kits fulfil the criteria as set out in Commission Delegated Regulation (EU) No. 2016/364 and it is classified as class A1.

This classification is valid as long as the insulation layer placed in the ventilated air space is made of a non-combustible material (mineral wool) or the layer behind the cladding elements is a mineral substrate like masonry or concrete (A1).

In other cases, the class of reaction to fire is NPA (No performance assessed).

A European reference fire scenario has not been laid down for facades. In some Member States, the classification of external wall cladding kits according to Standard EN 13501-1 might not be sufficient for the use in facades. An additional assessment of the system according to the national provision (e.g. based on a large-scale test) might be necessary to comply with Member State Regulations, until the existing European classification system has been completed.

### 3.2 Wind load resistance – BWR 4

Resistance to wind suction has been tested according to § 2.2.2 and the method specified in Annex B of EAD.

The kit behaviour exposed to wind pressure is most favourable than when exposed to wind suction. Therefore, wind pressure tests have been avoided and wind pressure resistance of kit can be considered as equal to wind suction resistance.

The mechanically weakest cases have been tested using:

- A generic skin element.
- A distance between cladding fixings and between vertical profiles<sup>(6)</sup> according to the dimension of the generic skin element used.

For PF 1011 OCULTO (Punctual hidden fixing) the generic skin element dimensions were 1000 x 500 x 11 mm, as consequence the distance between vertical profile was 1000 mm and the distance between cladding fixings 900-910 mm.

(6) The distance between vertical profiles and between cladding fixings is strictly related to the dimensions of the cladding element.



For PF 1011 VISTO (Punctual visible fixing) the generic skin element dimensions were 1200 x 600 x 11 mm, as consequence the distance between vertical profile was 1200 mm and the distance between cladding fixings 1100-1110 mm.

- The maximum distance between brackets (1200 mm).

Test results are indicated in table 3.

TABLE 3 – WIND SUCTION RESISTANCE TEST RESULTS				
TEST SPECIMEN	FAILURE LOAD $Q_k$ (kPa)	TYPE OF FAILURE	MAXIMUM PERMANENT DEFORMATION $\Delta d_{max}$ (mm)	MAXIMUM DEFLECTION UNDER LOAD $d_{max}$ (mm)
PF 1011 OCULTO – Punctual hidden fixing	2.4 <sup>(7)</sup>	Deformation of fixing and crack of the grooves of the skin elements	2.5	14.5
PF 1011 VISTO – Punctual visible fixing	3.6 <sup>(8)</sup>	Deformation of fixing and crack of skin element	8.3	49.7

The characteristic resistance to horizontal load determined by test is valid for the same or lower level of wind action determined according to EN 1991-1-4 and:

- The same type of brackets, positioned in lower span in vertical or horizontal position;
- Stronger type of bracket, positioned in the same or lower span in vertical or horizontal position;
- Profiles in vertical or horizontal position with the same or stronger inertia;
- The same type of fixings of skin elements (such as PF 1011 OCULTO/VISTO), positioned in lower span in vertical or horizontal position or in higher number used in one skin element;
- The same type of fasteners used in higher number between bracket and vertical profile and between vertical profile and fixings;
- Stronger type of fasteners used in the same or between bracket and vertical profile and between vertical profile and fixings.

### 3.3 Resistance to vertical load of skin element fixings – BWR 4

Resistance to vertical load of skin element fixings has been tested according to cl. 2.2.4 and the method specified in Annex D of EAD.

Test results are indicated in table 4.

TABLE 4 – RESISTANCE TO VERTICAL LOAD OF SKIN ELEMENT FIXINGS					
TEST SPECIMEN	1 mm PERMANENT DEFORMATION $F_i$ (N)		FAILURE VALUE $F_{iu}$ (N)		MODE OF FAILURE
	Mean value	Characteristic value	Mean value	Characteristic value	
PF 1011 OCULTO – Punctual hidden fixing (Type 2.a) – intermediate fixing	1530	1184.4	1920	1644.8	Significant permanent deformation (2-2.5 mm)
PF 1011 VISTO – Punctual visible fixing (Type 3.a) – intermediate fixing	1042	818.9	1280	1024.8	Significant permanent deformation (2.5 mm)

### 3.4 Resistance to horizontal load of skin element fixings – BWR 4

Resistance to horizontal load of skin element fixings has been tested according to cl. 2.2.5 and the method specified in Annex D of EAD.

(7) Test had to be stopped at 2,6 kPa because of the collapse of one of the skin element

(8) Test had to be stopped at 3,8 kPa because of the collapse of one of the skin element



Test results are indicated in table 5.

TEST SPECIMEN	1 mm PERMANENT DEFORMATION $F_i$ (N)		FAILURE VALUE $F_{iu}$ (N)		MODE OF FAILURE
	Mean value	Characteristic value	Mean value	Characteristic value	
PF 1011 OCULTO – Punctual hidden fixing (Type 2.a) – intermediate fixing	564	340.1	780	675.8	Significant permanent deformation (2-2.5 mm)
PF 1011 VISTO – Punctual visible fixing (Type 3.a) – Starter/Crown and intermediate fixing	746	641	1000	1000	Significant permanent deformation (1.5-2 mm)

### 3.5 Inertia and resistance of profiles – BWR 4

The following characteristics of the horizontal rail and the subframe profiles are given in the relevant tables of Annex A of this ETA:

- Form and dimensions of the profile section.
- Inertia of the profile section.
- Minimum elastic limit of the profile materials.

### 3.6 Resistance to vertical load of brackets– BWR 4

Brackets load bearing capacity and deformation under vertical load have been assessed according to § 2.2.11 and the method specified in Annex H, Cl. H.4 of EAD.

Mean and characteristic values of bracket resistance to vertical load test are indicated in table 6, these values correspond to the resistance to vertical load of 1 bracket.

BRACKETS DIMENSIONS	$R_{v,r}$ (N) $\Delta L=0.2\%$ of L Residual distortion		$R_{v,1mm}$ (N) $\Delta L=1mm$ Displacement		$R_{v,3mm}$ (N) $\Delta L=3mm$ Displacement		$R_{v,s}$ (N) $\Delta L=5$ mm Displacement Significant permanent distortion ( $\geq 2.5mm$ )	
	Mean value	Char. value	Mean value	Char. value	Mean value	Char. value	Mean value	Char. value
60x40x100 (t=4)	535	414.2	1365.5	1013.9	3832.4	3194.5	5772.8	5025.8
80x60x100 (t=5)	980	485	1698.2	1025.1	3892.5	3357.3	5427.2	5069.7
135x60x100 (t=5)	462	275.5	517.4	310.3	1096.8	733.5	1486.6	833.9
200x50x100 (t=4.2)	461	288.3	361.6	312.4	674.5	483.2	925.2	749.5

### 3.7 Resistance to horizontal load of brackets– BWR 4

Brackets load bearing capacity and deformation under horizontal load have been assessed according to § 2.2.12 and the method specified in Annex H, Cl. H.4 of EAD.

Mean and characteristic values of bracket resistance to horizontal load test are indicated in table 7, these values correspond to the resistance to horizontal load of 1 bracket.

BRACKETS DIMENSIONS	$R_{H,1mm}$ (N) $\Delta L=1mm$ Residual distortion		$R_{H,s}$ (N) $\Delta L=5$ mm Displacement Significant permanent distortion ( $\geq 2mm$ )	
	Mean value	Char. value	Mean value	Char. value
60x40x100 (t=4)	5860	4944.9	6779.1	5957.6
60x40x50 (t=4)	3385	3176.6	4334	4085.45
80x60x100 (t=5)	4695	3224.6	5035.5	3083.2
80x60x50 (t=5)	2162	2000.9	2594.4	2359.2
135x60x100 (t=5)	6250	5275.29	6920.7	6536.48
135x60x50 (t=5)	1722	1560.03	2200.3	1871.99
200x50x100 (t=4.2)	4490	4127.16	4904.3	4607.03
200x50x50 (t=4.2)	2155	1978.32	2644.7	2481.11



### 3.8 Mechanical characteristics of subframe fixings

See Annex A of this ETA.

### 3.9 Corrosion protection of metallic kit components

Fixings and subframe components are made of:

- Aluminium alloy AW-6063 according to EN 573, EN 755 and EN 1999-1-1, and their minimum thickness is  $\geq 2$ mm.

The durability class is B according to EN 1999-1-1:2007/A1:2009<sup>(9)</sup> (Table 3.1a and Table.C.1 in Annex C). Therefore, these components may be used in the following external atmospheric exposure: rural environment, moderate industrial/urban environment, but excluding industrial marine environment. These components may be used in other external atmospheric conditions exposure if the components are protected as indicated in EN 1999-1-1.

- A2 stainless steel according to EN ISO 3506-1.

The category of corrosivity is C4 (High) according to EN 1993-1-4:2006<sup>(10)</sup> (Table A.1 in Annex A) and EN ISO 9223: 2012<sup>(11)</sup> (Table C.1 in Annex C). Therefore, these components may be used in indoor environments with high frequency of condensation and high pollution from production process (e.g. industrial processing plants, swimming pools) and in outdoor environments, temperate zone, with high pollution (e.g. polluted urban areas, industrial areas, coastal areas without spray of salt water) or, subtropical and tropical zone, with medium pollution.

## 4. Assessment and verification of constancy of performance (hereinafter AVCP) system applied. with reference to its legal base

According to the decision 2003/640/EC of the European Commission <sup>(12)</sup> the system of assessment and verification of constancy of performances (see Annex V to Regulation (EU) N° 305/2011) given in the following table applies:

Product(s)	Intended use(s)	Level(s) or class(es)	System(s)
Kits composed by subframe and fixings for fastening cladding and external wall elements GRAPAMAR PF1011 OCULTO and GRAPAMAR PF1011 VISTO	Mechanical fastening of skin elements in façades with air space, ventilated or not	-	2+

## 5. Technical details necessary for the implementation of the AVCP system. as provided for in the applicable EAD

Technical details necessary for the implementation of the AVCP system are laid down in the quality plan deposited at IETcc <sup>(13)</sup>.

Issued in Madrid, 08<sup>th</sup> February 2024

by

**Ángel Castillo Talavera**

Director

on behalf of Instituto de Ciencias de la Construcción Eduardo Torroja (IETcc-CSIC)

(9) EN 1999-1-1:2007+A1:2009 "Eurocode 9. Design of aluminium structures - Part 1-1: General structural rules".

(10) EN 1993-1-4:2006 "Eurocode 3 Design of steel structures - Part 1-4: General rules - Supplementary rules for stainless steels".

(11) EN ISO 9223:2012 "Corrosion of metals and alloys - Corrosivity of atmospheres - Classification, determination and estimation".

(12) 2003/640/EC – Commission Decision of date 4 September 2003, published in the Official Journal of the European Union (OJEU) L226/21 of 10/09/2003.

(13) The Control Plan is a confidential part of the ETA and only handed over to the notified certification body involved in the assessment and verification of constancy of performance.



**Note:** The details shown in figures on this page and on the following pages are approximate and must be defined for each project depending on the site of the building.  
These details concern the kit for ventilated external wall claddings and may not be used as justification for compliance with the National requirements.

FIGURE 1-A. PF 1011 OCULTO – PUNCTUAL HIDDEN FIXING

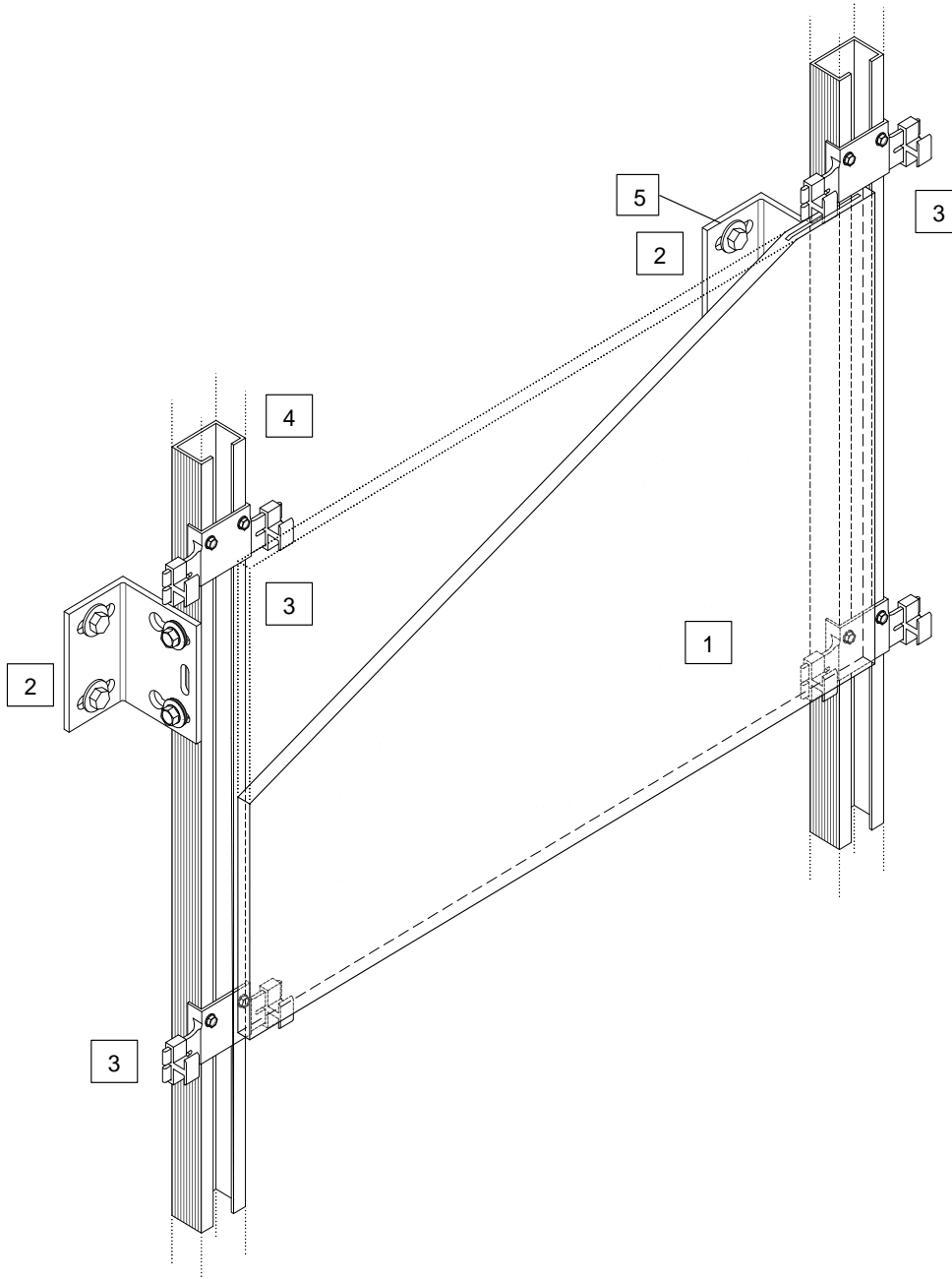

1. Generic skin element – Porcelain stoneware
2. Bracket
3. Skin element fixing – Punctual hidden fixing – PF 1011 OCULTO (intermediate)
4. "C" fluted vertical profile
5. Anchor to the support wall





FIGURE 1-B. PF 1011 VISTO – PUNCTUAL VISIBLE FIXING

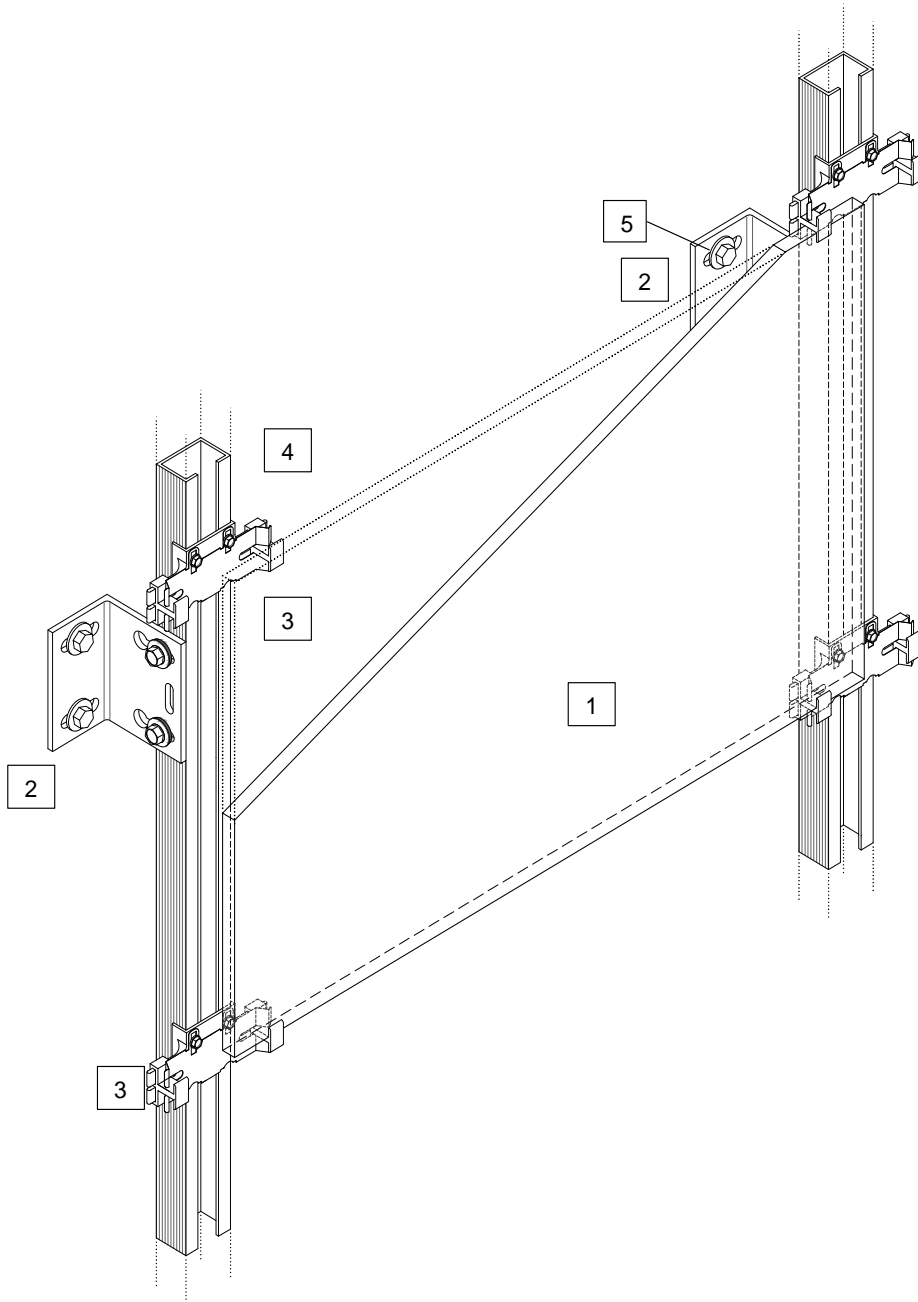

1. Generic skin element – Porcelain stoneware
2. Bracket
3. Skin element fixing– Punctual visible fixing - PF 1011 VISTO (intermediate)
4. “C” fluted vertical profile
5. Anchor to the support wall



### SYSTEM COMPONENTS

#### FIGURE 2. SUPPORTING BRACKETS

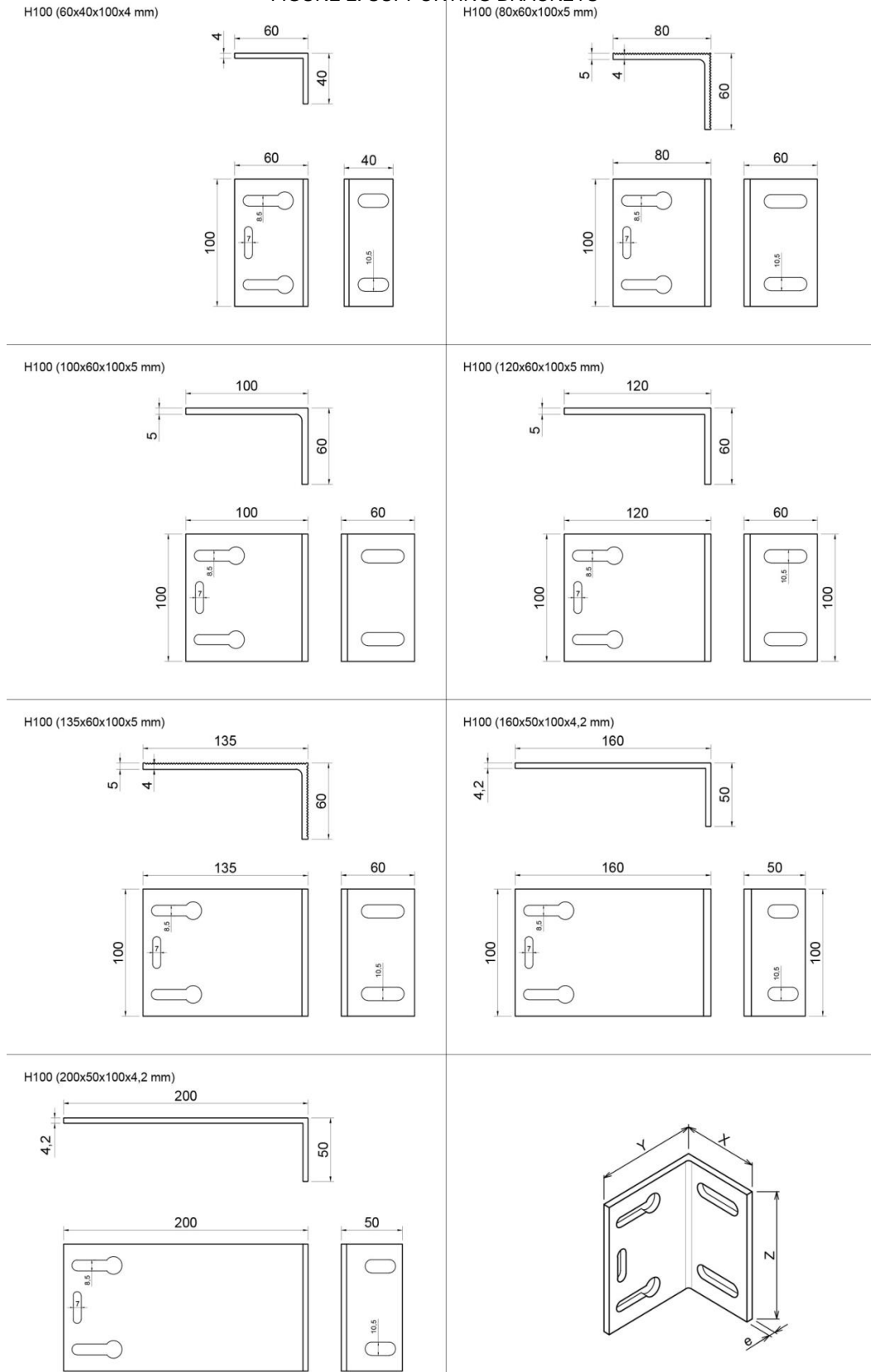
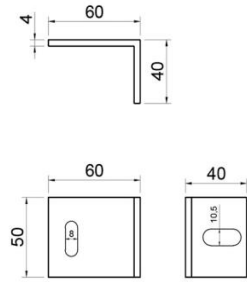
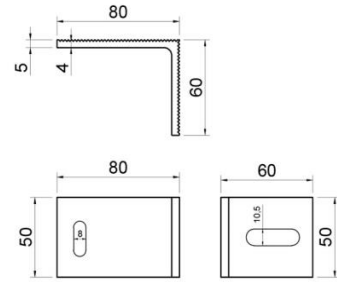

FIGURE 3. RETENTION BRACKETS

H50 (60x40x50x4 mm)



H50 (80x60x50x5 mm)



H50 (100x60x50x5 mm)

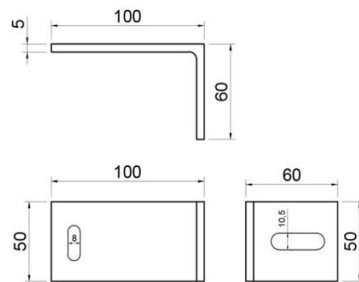

H50 (120x60x50x5 mm)

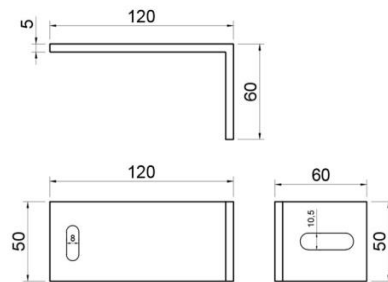

H50 (135x60x50x5 mm)

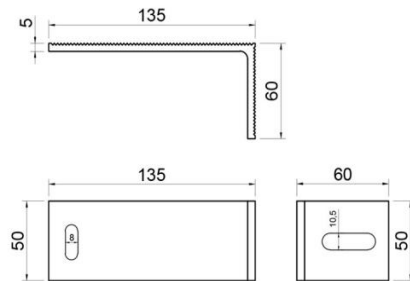

H50 (160x50x50x4,2 mm)

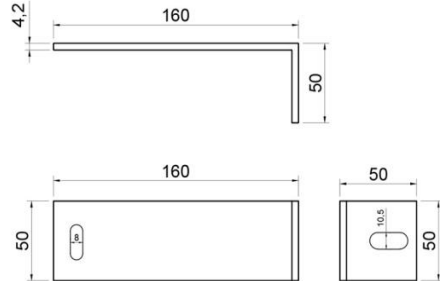

H50 (200x50x50x4,2 mm)

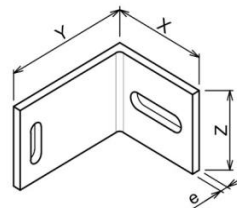
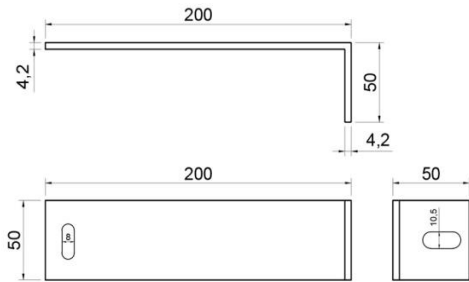

FIGURE 4. VERTICAL PROFILE "C" INSTALLATION

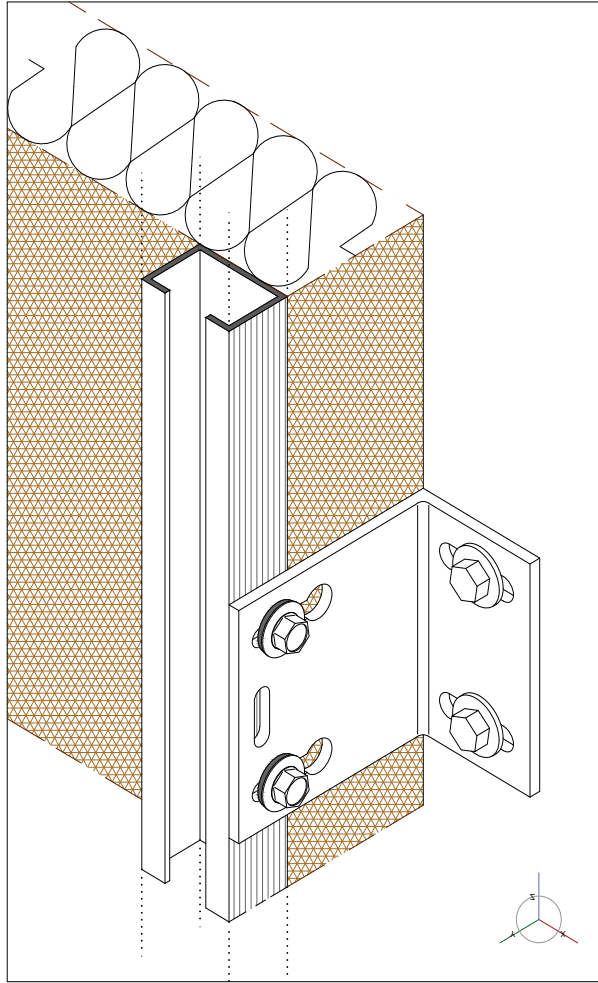

FIGURE 5. "C" VERTICAL PROFILE- SECTION

FIGURE 5-A. FLUTED PROFILE

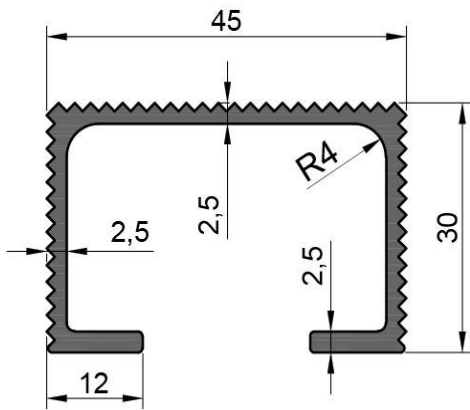

FIGURE 5-B. FLAT PROFILE

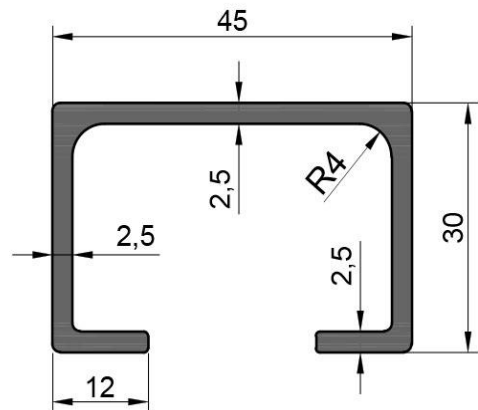
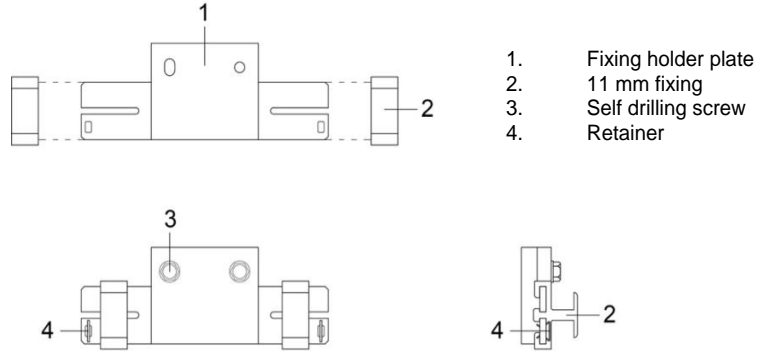
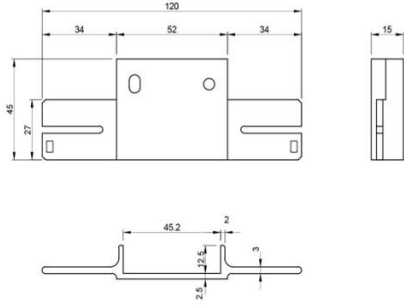

FIGURE 6. SKIN ELEMENT FIXING

FIGURE 6-A. PUNCTUAL HIDDEN FIXING - PF1011 OCULTO



INTERMEDIATE AND STARTER FIXING HOLDER PLATE



CROWN FIXING HOLDER PLATE

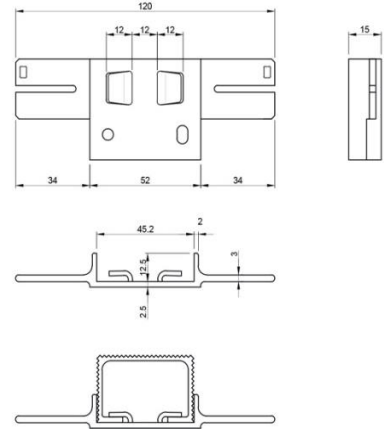

INTERMEDIATE 11 mm FIXING

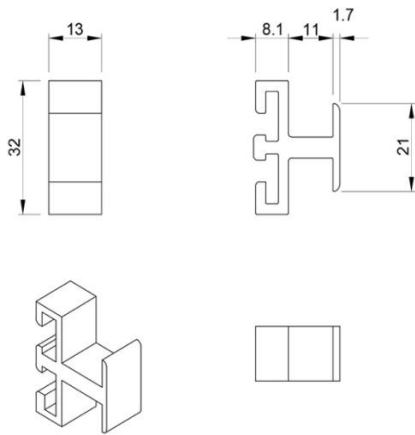

CROWN / STARTER 11 mm FIXING

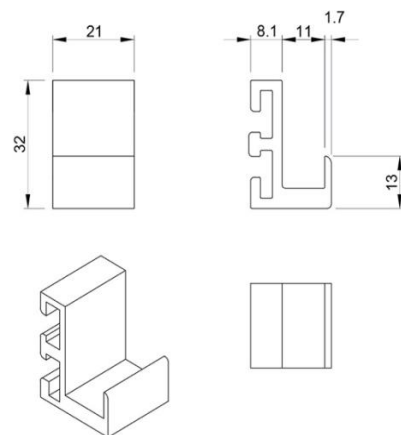
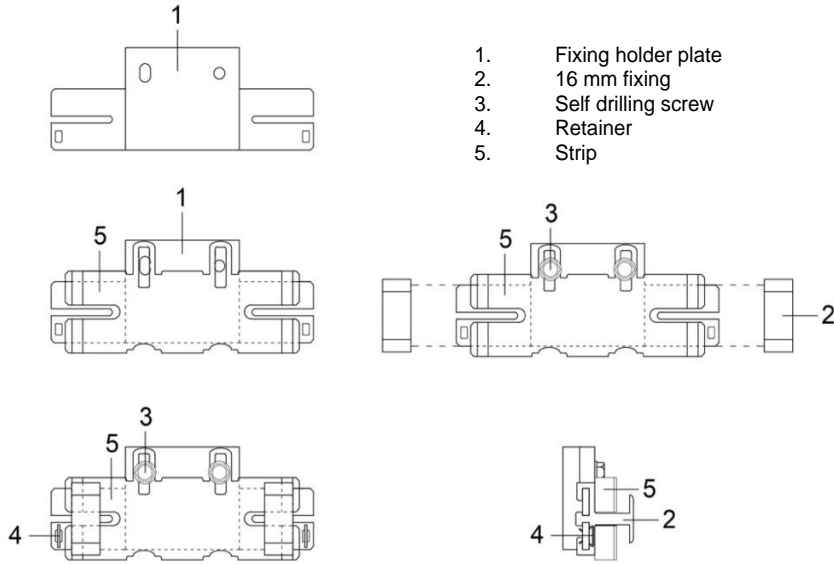
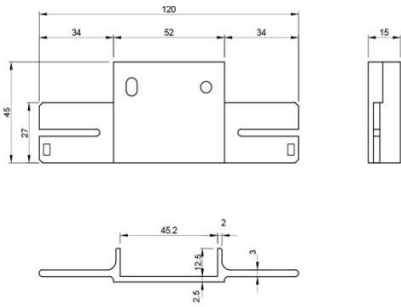

FIGURE 6-B. PUNCTUAL VISIBLE FIXING - PF1011 VISTO



1. Fixing holder plate
2. 16 mm fixing
3. Self drilling screw
4. Retainer
5. Strip

INTERMEDIATE AND STARTER FIXING HOLDER PLATE



CROWN FIXING HOLDER PLATE

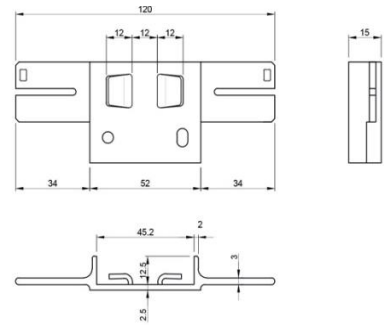

STRIP

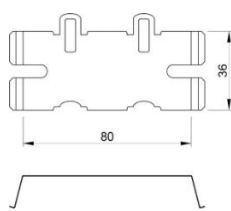

INTERMEDIATE 16 mm FIXING

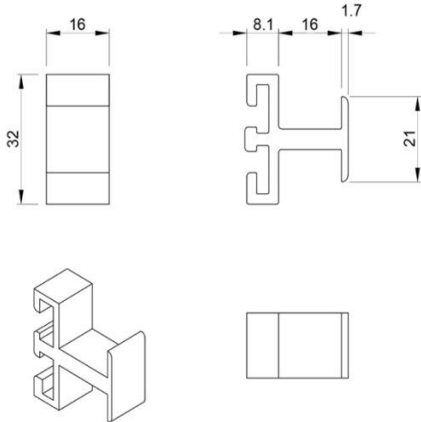

CROWN / STARTER 16 mm FIXING



FIGURA 7. INSTALLATION STEPS

1.- PLACEMENT OF BRACKETS ALTERNATIVELY



2.- PLACEMENT OF VERTICAL PROFILES (HEAD ON)

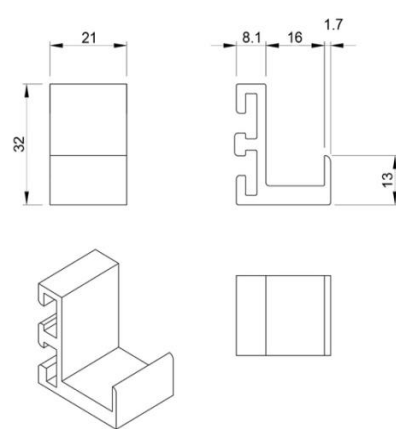
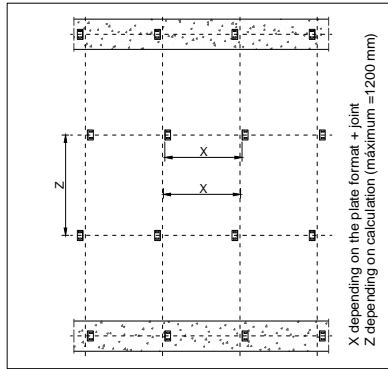
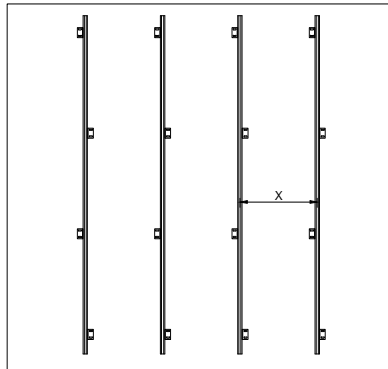

3.- PLACEMENT OF STARTER FIXINGS

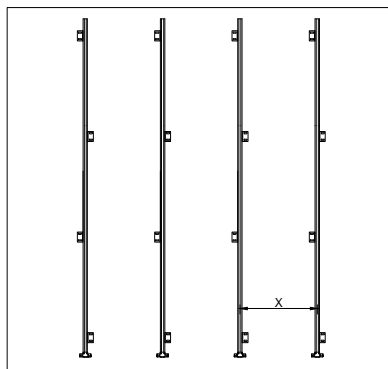

4.- SUCCESSIVE PLACEMENT OF FIXINGS AND TILES

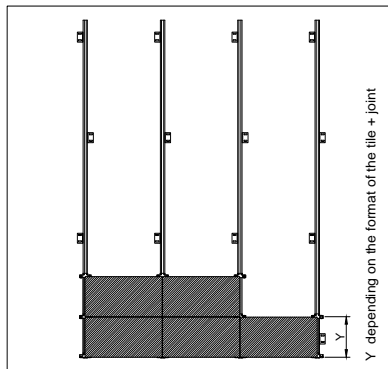

FIGURE 8. VERTICAL SECTION

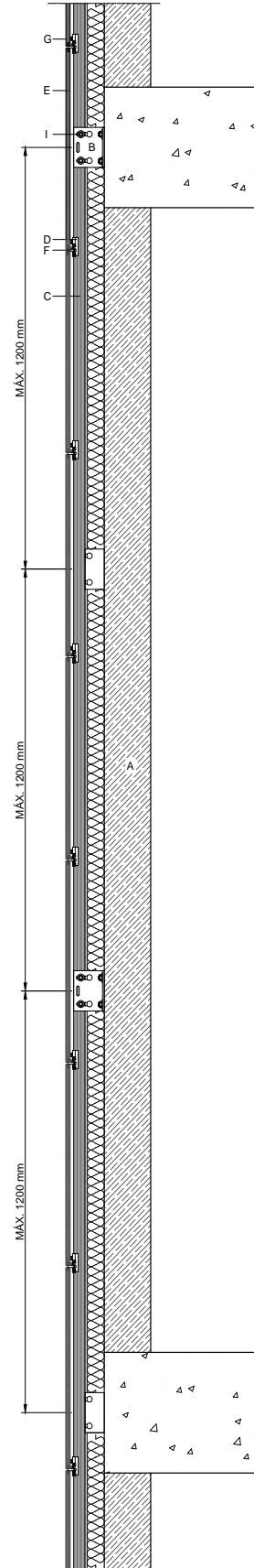
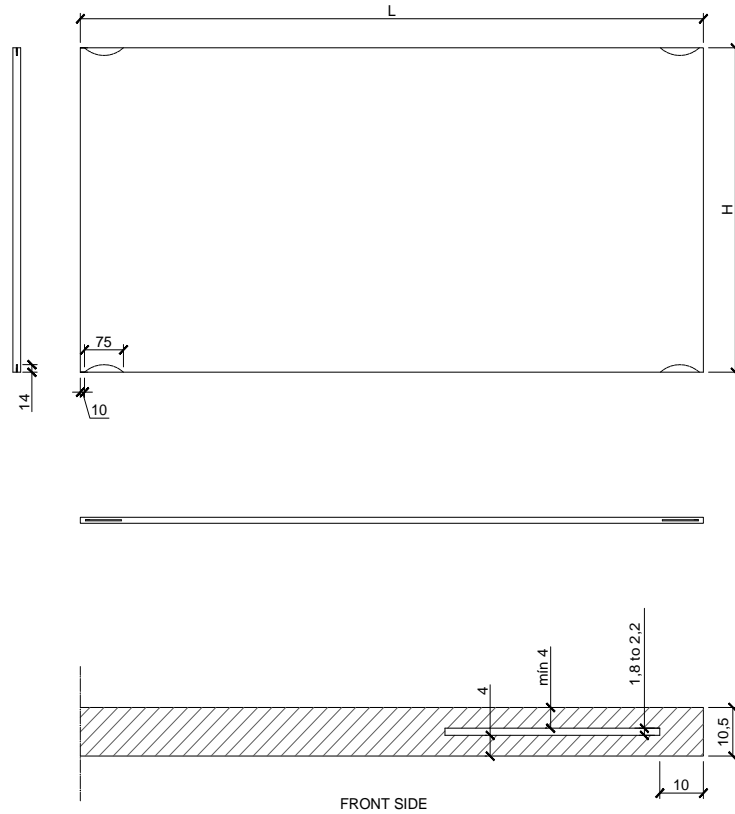

FIGURE 9. GENERIC SKIN ELEMENT WITH GROOVES – PF 1011 OCULTO



Note: In the kit PF 1011 VISTO, the generic skin element doesn't have grooves

### FIGURES LEGEND

- A.- SUPPORT WALL
- B.- BRACKET TO SUPPORT WALL
- C.- "C" VERTICAL PROFILE (30 x 45 mm)
- D.- FIXING HOLDER PLATE
- E.- GENERIC SKIN ELEMENT (PORCELAIN STONEWARE)
- F.- FIXING
- G.- SELF-DRILLING SCREW ( $\varnothing$  4.8 mm L=16 mm)
- H.- STRIP
- I.- SELF-DRILLING SCREW WITH EPDM WASHER ( $\varnothing$  6.3 mm L=25 mm)
- J.- POLYURETHANE RESIN
- K.- ANCHORAGE TO THE SUPPORT WALL





FIGURE 10. DETAIL OF SUBFRAME AND FIXING SYSTEM – VERTICAL AND HORIZONTAL SECTION

FIGURE 10-A. PF 1011 OCULTO

FIGURE 10-B. PF 1011 VSTO

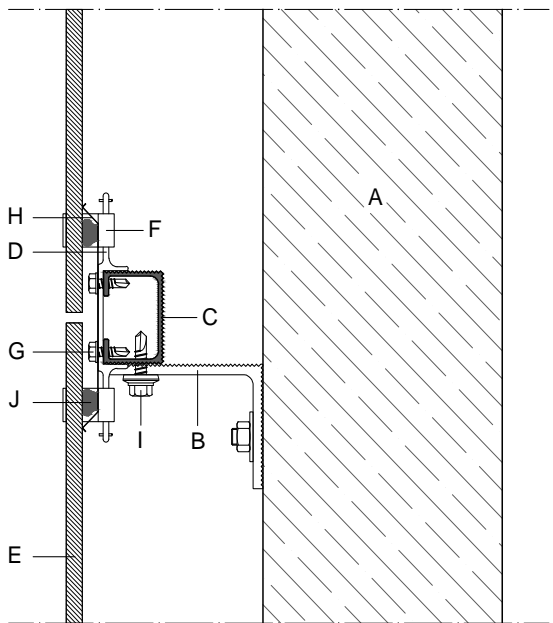
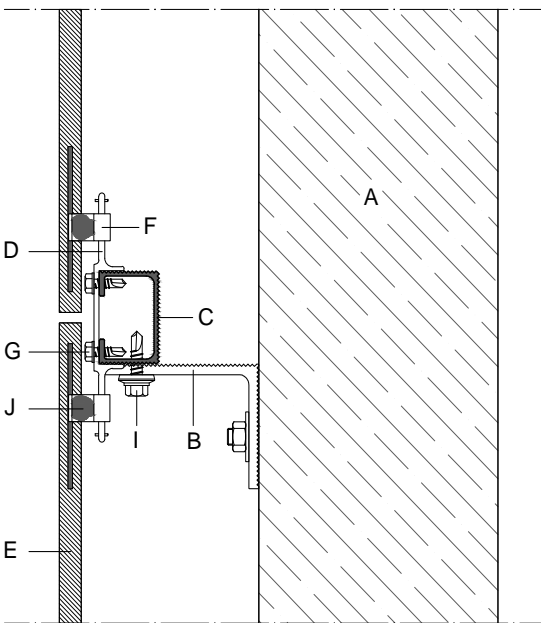
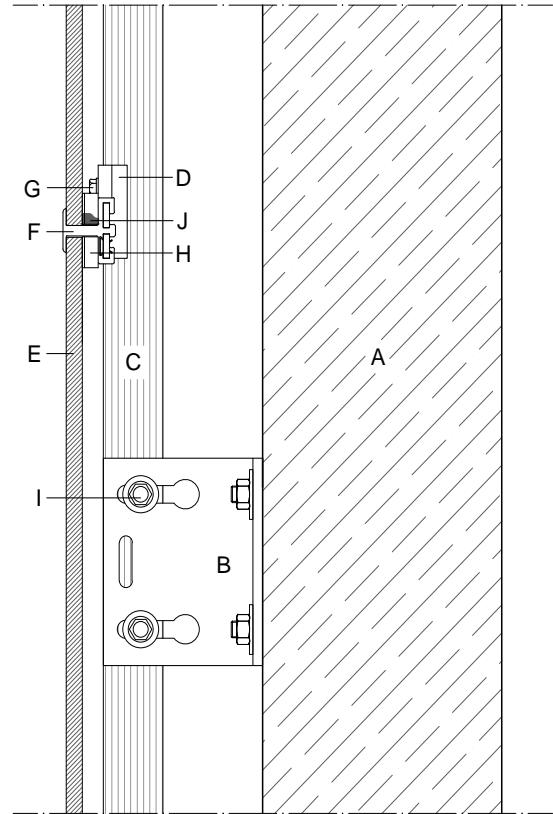
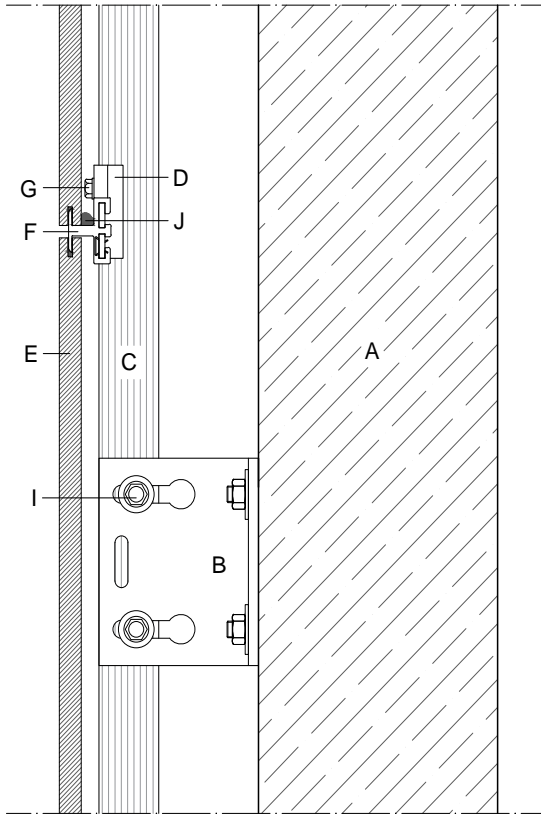

FIGURE 11. CROWN AND BASE DETAIL

FIGURE 11-A. PF 1011 OCULTO

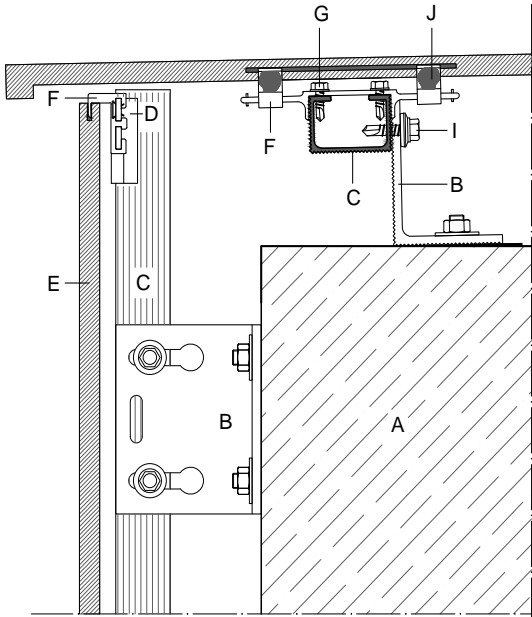

FIGURE 11-B. PF 1011 VISTO

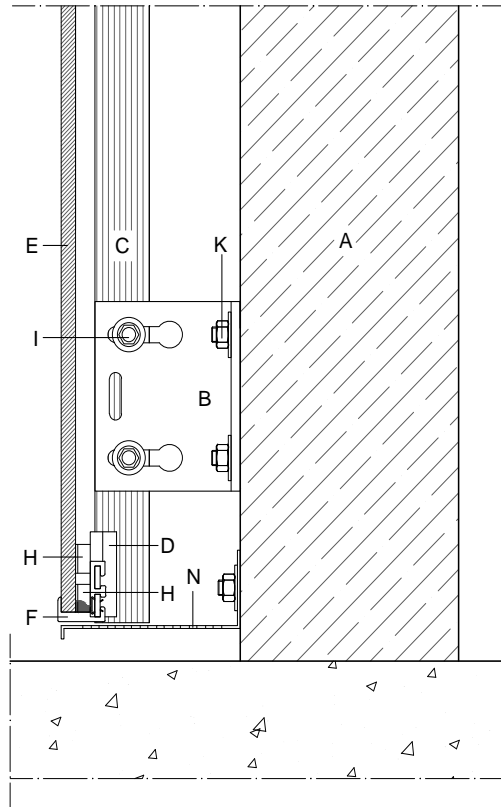
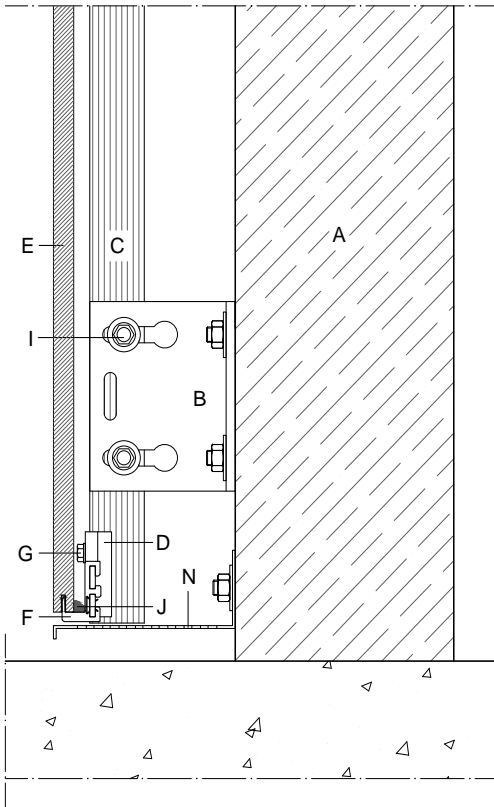
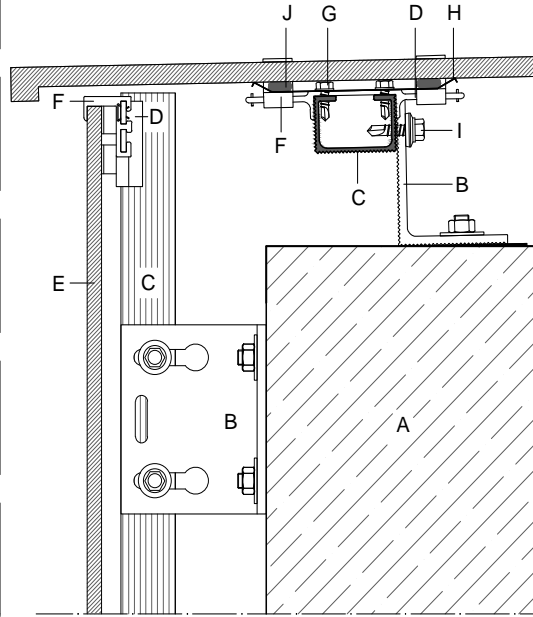

FIGURE 12. EXTERNAL CORNER DETAIL

FIGURE 12-A. PF 1011 OCULTO

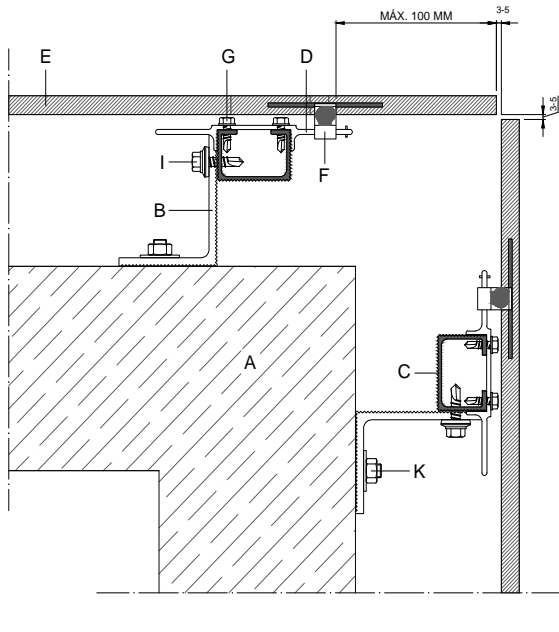

FIGURE 12-B. PF 1011 VISTO

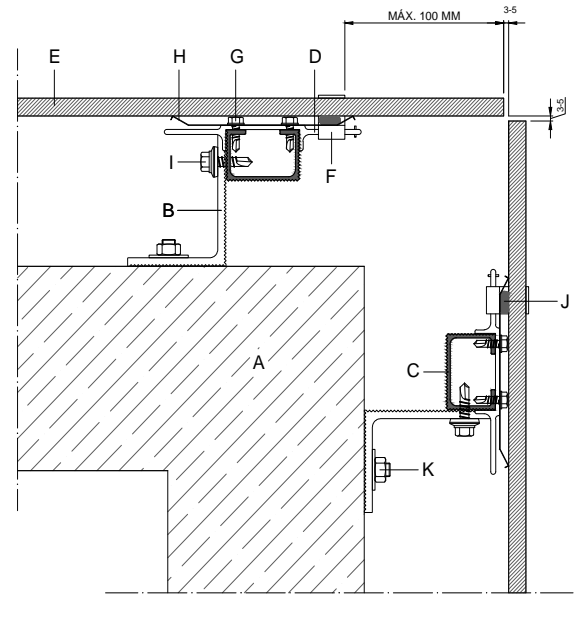

FIGURE 13. INTERNAL CORNER DETAIL

FIGURE 13-A. PF 1011 OCULTO

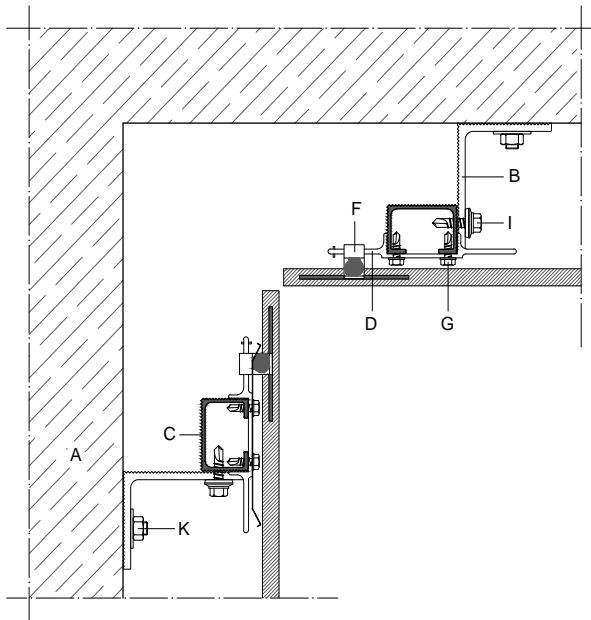

FIGURE 13-B. PF 1011 VISTO

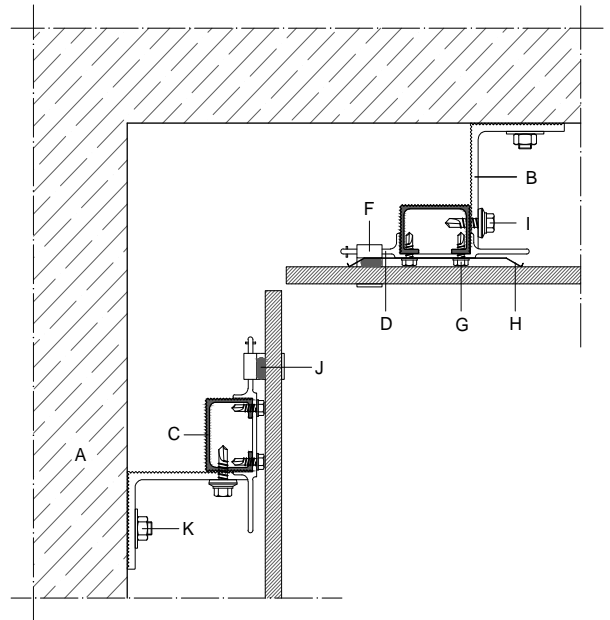
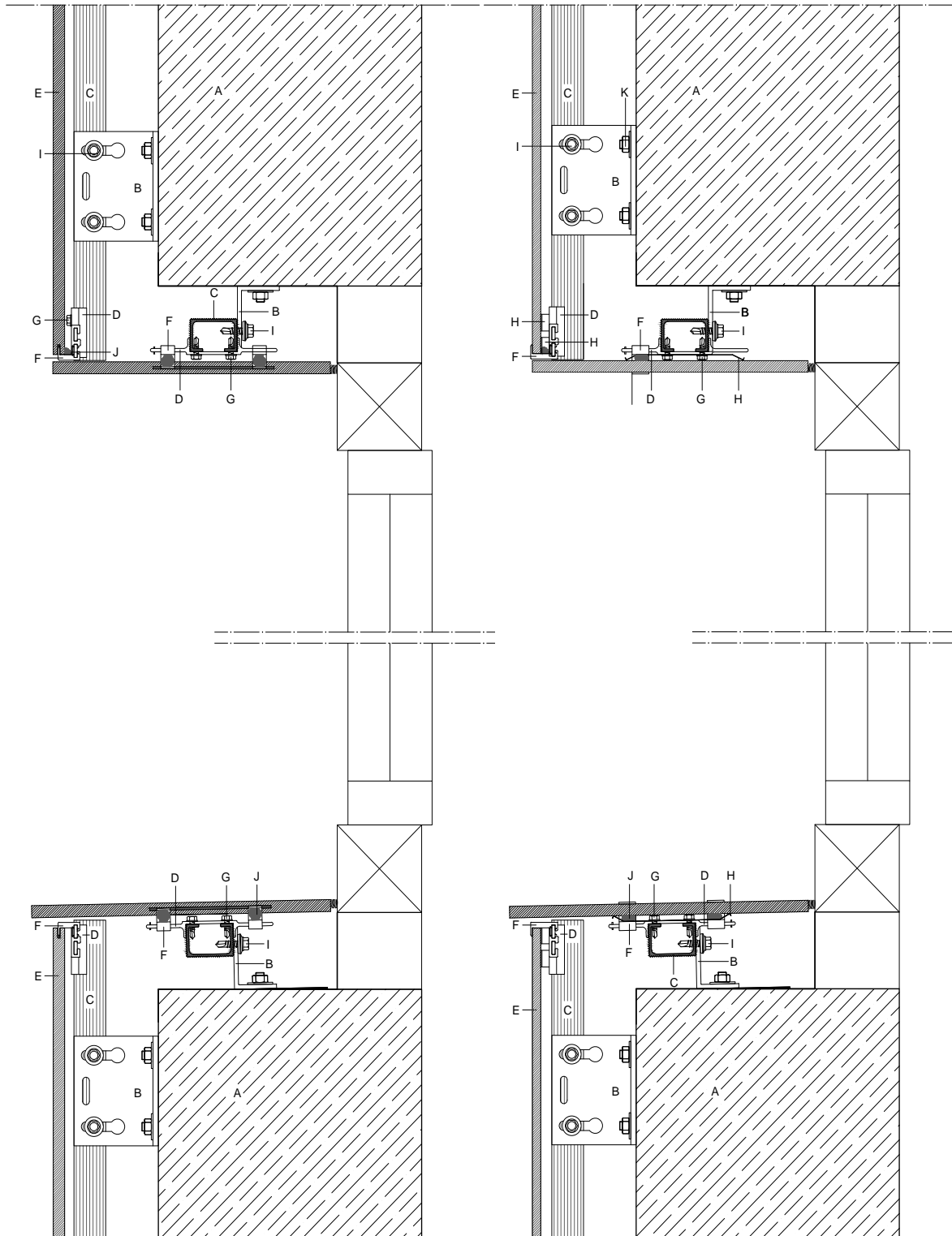

FIGURE 14. WINDOW DETAIL – VERTICAL SECTION

FIGURE 14-A. PF 1011 OCULTO

FIGURE 14-B. PF 1011 VISTO



## Annex A: Fixings and Subframe specifications

### Material of fixings and subframe

#### Aluminium physical and mechanical properties

Symbolic designation	EN AW-Al MgSi
Numeric designation	EN AW 6063 <sup>(14)</sup> AlMg0,7Si
Treatment	T6
PHYSICAL PROPERTIES	
Density	2,7 g/cm <sup>3</sup>
Coefficient of linear thermal expansion (20 <sup>o</sup> -100 <sup>o</sup> C)	23,2 x 10 <sup>-6</sup> °C
Elastic modulus	69 500 N/mm <sup>2</sup>
MECHANICAL PROPERTIES	
Tensile strength (R <sub>m</sub> )	215 MPa
Elastic limit (R <sub>p0,2</sub> )	170 MPa
Elongation (A <sub>50mm</sub> )	6 %
Brinell hardness	75
According to EN 755-2: 2016 <sup>(15)</sup> and EN 12020-1: 2022 <sup>(16)</sup>	

### Skin elements fixings

#### PF 1011 OCULTO (Punctual hidden fixing) geometrical and mechanical features

Reference	Fixing holder plate	Intermediate fixing	Starter /Crown fixing	Retainer
Dimensions	Figure 6-A	Figure 6-A	Figure 6-A	Figure 6-A

#### PF 1011 VISTO (Punctual visible fixing) geometrical and mechanical features

Reference	Fixing holder plate	Strip	Intermediate fixing	Starter /Crown fixing	Retainer
Dimensions	Figure 6-B	Figure 6-B	Figure 6-B	Figure 6-B	Figure 6-B

### Subframe specifications

#### Vertical profiles geometrical and mechanical features

Reference	"C" 30 x 45 x 2.5 (fluted)	"C" 30 x 45 x 2.5 (flat)
Thickness (mm)	2.5	2.5
Section (mm <sup>2</sup> )	248.68	303.72
Perimeter (mm)	279.10	2336.13
Weight (kg/m)	0.671	0.820
x <sub>c</sub> (mm)	22.50	22.50
I <sub>xc</sub> (cm <sup>4</sup> )	3.24	3.79
r <sub>xc</sub> (mm)	11.31	11.17
y <sub>c</sub> (mm)	16.88	17.63
I <sub>yc</sub> (cm <sup>4</sup> )	7.71	9.48
r <sub>yc</sub> (mm)	17.46	17.67

#### Brackets geometrical and mechanical features

Reference	60x40x100/50	80x60x100/50	100x60x100/50	120x60x100/50	135x60x100/50	160x50x100/50	200x50x100/50
Thickness (mm)	4	5	5	5	5	4,2	4,2
Section (mm <sup>2</sup> )	384	617	780	874	867	864	1032
Perimeter (mm)	199	328	317	359	457	419	499
Weight (kg/m)	1,04	1,67	2,11	2,36	2,32	2,33	2,79
x <sub>c</sub> (mm)	19,50	55,27	67,04	78,07	48,54	97,34	81,76
I <sub>xc</sub> (cm <sup>4</sup> )	5,18	19,55	23,02	24,02	22,06	12,80	13,26
r <sub>xc</sub> (mm)	11,62	17,80	17,18	16,57	16,01	12,17	11,33
y <sub>c</sub> (mm)	9,50	45,18	46,91	48,07	11,36	42,34	6,76
I <sub>yc</sub> (cm <sup>4</sup> )	14,27	40,15	82,12	134,37	167,17	234,09	429,96
r <sub>yc</sub> (mm)	19,28	25,52	32,44	39,19	44,08	52,04	64,54

(14) Aluminium alloy 6063 T6 is classified as class B according to (Eurocode 9): EN 1999-1-1:2007+A1:2009 Design of aluminium structures. General structural rules. Table 3.1 and Table.C.1 in Annex C.

(15) EN 755-2: 2016 Aluminium and aluminium alloys. Extruded rod/bar, tube and profiles. Part 2: Mechanical properties.

(16) EN 12020-1: 2022 Aluminium and aluminium alloys. Extruded precision profiles in alloys EN AW-6060 and EN AW-6063. Part 1: technical conditions for inspection and delivery.



## Subframe fixings

### Stainless steel screw between Bracket and Vertical profile

Designation	DIN 7504 K with EPDM washer
Diameter	6,3 mm
Length	25 mm
Material	Stainless steel A2 (AISI 304)
Standard	EN ISO 3506 <sup>(17)</sup>
Tension resistance ( $R_m$ )	13.36 kN
Shear resistance	6.68 kN

### Stainless steel screw between Vertical profile and Punctual fixing

Designation	DIN 7504 K
Diameter	4,8 mm
Length	16 mm
Material	Stainless steel A2 (AISI 304)
Standard	EN ISO 3506
Tension resistance ( $R_m$ )	7,11 kN
Shear resistance	3,56 kN

## Annex B: Auxiliary components

### Adhesive: Polyurethane resin<sup>(18)</sup>

Reaction to fire	Class E
Loss of volume	≤ 10%
Resistance to flow	≤ 3 mm

### Anchorage to substrate

The fixings between the subframe and the substrate are not part of the kit, therefore have not been assessed, even so it is important define type, position and number of the anchorage according to the substrate material and the resistance required due to the envisaged actions and when possible, CE marking according to the ETA via EAD 330232-00-0601, 330499-00-0601, 330747-00-0601, 330076-00-0604, etc. is recommended.

## Annex C: Confidential information

### Quality control of components of kits manufactured by suppliers or ETA holder.

This information is confidential and it is not included in the European Technical Assessment when that assessment is publicly available.

(17) EN ISO 3506-1:2021 Fasteners - Mechanical properties of corrosion-resistant stainless steel fasteners - Part 1: Bolts, screws and studs with specified grades and property classes (ISO 3506-1:2020)

(18) EN 15651-1:2012 Sealants for non-structural use in joints in buildings and pedestrian walkways - Part 1: Sealants for facade elements

