



**INSTITUTO DE CIENCIAS
DE LA CONSTRUCCIÓN
EDUARDO TORROJA**

C/ Serrano Galvache n. 4 28033 Madrid (Spain)
Tel.: (34) 91 302 04 40 Fax: (34) 91 302 07 00
direccion.ietcc@csic.es www.ietcc.csic.es



European Technical Assessment

ETA 24/0399 of 08/05/2024

English translation prepared by IETcc. Original version in Spanish language

General Part

Technical Assessment Body issuing the ETA designated according to Art. 29 of Regulation (EU) 305/2011:

Instituto de Ciencias de la Construcción Eduardo Torroja (IETcc)

Trade name of the construction product

Ceiling anchor SDA (CE)

Product family to which the construction product belongs

Anchor made of galvanized steel for multiple use for non-structural applications in concrete.

Manufacturer

ITW Construction Products Italy srl.
Viale Regione Veneto, 5
35127 Padova Z.I. (PD), Italy
website: www.itw-elematic.com

Manufacturing plants

ITW plant 6

This European Technical Assessment contains

8 pages including 3 annexes which form an integral part of this assessment.

This European Technical Assessment is issued in accordance with regulation (EU) No 305/2011, on the basis of

European Assessment Document 330474-00-0601 "Fasteners for use in concrete for redundant non-structural systems", edition May 2018



English translation prepared by IETcc

This European Technical Assessment is issued by the Technical Assessment Body in its official language. Translations of this European Technical Assessment in other languages shall fully correspond to the original issued document and should be identified as such.

This European Technical Assessment may be withdrawn by the issuing Technical Assessment Body, in particular pursuant to information by the Commission according to article 25 (3) of Regulation (EU) No 305/2011.

Código seguro de Verificación : GEN-0f9f-b06c-26c0-56e2-9c62-dfbd-a23a-a0cc | Puede verificar la integridad de este documento en la siguiente dirección : <https://sede.administracion.gob.es/pagSedeFront/servicios/consulta...>

CSV : GEN-0f9f-b06c-26c0-56e2-9c62-dfbd-a23a-a0cc

DIRECCIÓN DE VALIDACIÓN : <https://sede.administracion.gob.es/pagSedeFront/servicios/consultaCSV.htm>

FIRMANTE(1) : ANGEL CASTILLO TALAVERA | FECHA : 20/05/2024 10:02 | Sin acción específica



SPECIFIC PART

1. Technical description of the product

The ITW ceiling anchor SDA (CE) in diameter 6 is an anchor made of galvanized steel. The anchor is installed into a predrilled cylindrical hole and anchored by deformation-controlled expansion.

Product and product description is given in annex A.

2. Specification of the intended use in accordance with the applicable European Assessment Document.

The performances given in section 3 are only valid if the anchor is used in compliance with the specifications and conditions given in annex B.

The verifications and assessment methods on which this European Technical Assessment is based lead to the assumption of a working life of the anchor of at least 50 years. The indications given on the working life cannot be interpreted as a guarantee given by the producer, but are to be regarded only as a mean to choosing the right products in relation to the expected economically reasonable working life of the works.

3. Performance of the product and references to the methods used for its assessment

3.1 Safety in case of fire (BWR 2)

Essential characteristic	Performance
Reaction to fire	Anchorage satisfy requirements for class A1
Essential characteristics under fire exposure	See annex C2

3.2 Safety in use (BWR 4)

Essential characteristic	Performance
Essential characteristics in concrete	See annex C2

4. Assessment and Verification of Constancy of Performances (hereinafter AVCP) system applied, with reference to its legal base

The applicable European legal act for the system of Assessment and Verification of Constancy of Performances (see annex V to Regulation (EU) No 305/2011) is 97/161/EC.

The system to be applied is 2+.

5. Technical details necessary for the implementation of the AVCP system, as provided for in the applicable European Assessment Document.

The technical details necessary for the implementation of the AVCP system are laid down in the quality plan deposited at Instituto de ciencias de la construcción Eduardo Torroja.



English translation prepared by IETcc



Instituto de ciencias de la construcción Eduardo Torroja
CONSEJO SUPERIOR DE INVESTIGACIONES CIENTÍFICAS

C/ Serrano Galvache n.º 4. 28033 Madrid.
Tel: (+34) 91 302 04 40 Fax. (+34) 91 302 07 00
www.ietcc.csic.es



On behalf of the Instituto de Ciencias de la Construcción Eduardo Torroja
Madrid, 8th of May 2024

Mr. Ángel Castillo Talavera
Director



Product and installed condition

SDA (CE) ceiling anchor

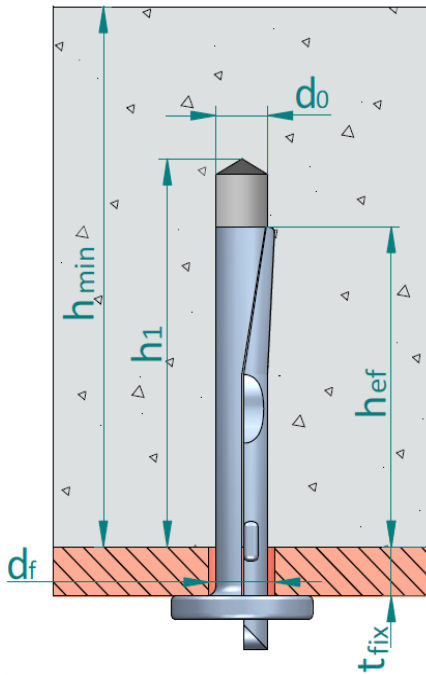
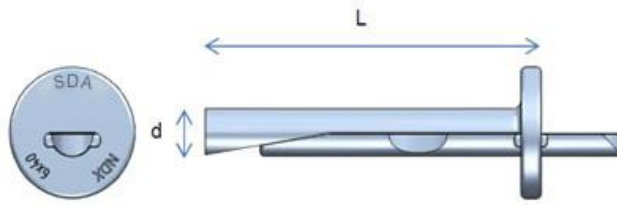

Anchor dimensions	6x40	6x70
d: diameter [mm]	6	6
L: length [mm]	40	70

- d₀: Nominal diameter of drill
- d_f: Fixture clearance hole diameter
- h_{ef}: Effective anchorage depth
- h₁: Depth of drilled hole
- h_{min}: Minimum thickness of concrete member
- t_{fix}: Fixture thickness

Table A1: materials

Item	Designation	Material for SDA (CE)
1	Anchor body	Carbon steel wire rod, galvanized ≥ 5 μm ISO 4042 A2
2	Shank	Carbon steel wire rod, galvanized ≥ 5 μm ISO 4042 A2

SDA (CE) ceiling anchor

Product description

Installed condition and materials

Annex A1



Specifications of intended use

Anchorage subjected to:

- Static or quasi static loads for redundant non-structural systems.
- Use for anchorages with requirements related to resistance of fire.
- The anchor may only be used if in the design and installation specifications for the fixture the excessive slip or failure of one anchor will not result in a significant violation of the requirements on the fixture in the serviceability and ultimate state.

Base materials:

- Reinforced or unreinforced normal weight concrete without fibres according to EN 206-1:2013+A1:2016.
- Strength classes C20/25 to C50/60 according to EN 206-1:2013+A1:2016.
- Cracked or uncracked concrete

Use conditions (environmental conditions):

- Anchorages subjected to dry internal conditions.

Design:

- Anchorages are designed under the responsibility of an engineer experienced in anchorages and concrete.
- Verifiable calculation rules and drawings are prepared taking into account of the loads to be anchored. The position of the anchor is indicated on the design drawings (e.g. position of the anchor relative to reinforcement or to supports, etc.).
- Anchorages under static or quasi-static actions are designed for design method C in accordance with EN 1992-4:2018
- Anchorages under fire exposure are designed in accordance to EN 1992-4:2018. It must be ensured that local spalling of the concrete cover does not occur.

Installation:

- Hole drilling by rotary plus hammer mode.
- Anchor installation carried out by appropriately qualified personal and under the supervision of the person responsible for technical matters of the site.
- Anchor expansion by impact on the shank. The anchor is properly set, if no further driving by impact is possible and the excess of the shank is at maximum 2,5 mm.
- The anchor may only be set once.

SDA (CE) ceiling anchor

Intended use

Specifications

Annex B1



Table C1: Installation parameters for SDA (CE) ceiling anchor

Installation parameters			Performances	
			SDA (CE) 6 x 40	SDA (CE) 6 x 70
d_0	Nominal diameter of drill bit:	[mm]	6	
d_f	Fixture clearance hole diameter:	[mm]	7	
h_{min}	Minimum thickness of concrete member:	[mm]	80	
h_1	Depth of drilled hole \geq	[mm]	40	
h_{ef}	Effective anchorage depth \geq	[mm]	32	
t_{fix}	Thickness of fixture:	[mm]	0 - 5	0 - 35
s_{min}	Minimum spacing:	[mm]	200	
c_{min}	Minimum edge distance:	[mm]	150	

Installation process

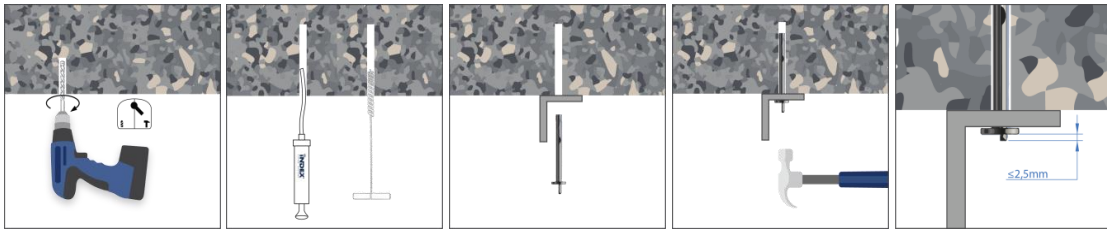

SDA (CE) ceiling anchor

Performances

Installation parameters and installation procedure

Annex C1



Table C2: Essential characteristics in concrete to loads of design method C according to EN 1992-4 for SDA (CE) ceiling anchor.

Characteristic values of resistance to loads of design method C		Performances	
		SDA (CE) 6 x 40	SDA (CE) 6 x 70
Any load direction			
F_{Rk}^0	Characteristic resistance in C20/25 to C50/60 concrete:	[kN]	3,0
γ_{inst}	Installation safety factor: ¹⁾	[-]	1,2
Shear loads: steel failure with lever arm			
$M_{Rk,s}^0$	Characteristic bending moment	[Nm]	3,68
γ_{Ms}	Partial safety factor: ¹⁾	[-]	1,25

¹⁾ in absence of other national regulations

Table C3: Essential characteristics under fire exposure in concrete in any load direction according to EN 1992-4 for SDA (CE) ceiling anchor

Characteristic resistance under fire exposure in concrete C20/25 to C50/60 in any load direction		Performances	
		SDA(CE) 6 x 40	SDA (CE) 6 x 70
R30	Characteristic resistance $F_{Rk,fi,30}^0$ ¹⁾	[kN]	0,41
R60	Characteristic resistance $F_{Rk,fi,60}^0$ ¹⁾	[kN]	0,30
R90	Characteristic resistance $F_{Rk,fi,90}^0$ ¹⁾	[kN]	0,19
R120	Characteristic resistance $F_{Rk,fi,120}^0$ ¹⁾	[kN]	0,14
R30 to R120	Minimum spacing $s_{min,fi}$	[mm]	200
	Minimum edge distance $c_{min,fi}$ ²⁾	[mm]	150

¹⁾ in absence of other national regulations the partial safety factor for resistance under fire exposure $\gamma_{M,fi}=1.0$ is recommended.

²⁾ If fire attack is from more than one side, the design method may be taken if edge distance of the anchor is $c \geq 300$

SDA (CE) ceiling anchor

Performances

Essential characteristics in concrete
Essential characteristics under fire exposure

Annex C2

