



**INSTITUTO DE CIENCIAS  
DE LA CONSTRUCCIÓN  
EDUARDO TORROJA**

C/ Serrano Galvache n. 4 28033 Madrid (Spain)  
Tel.: (34) 91 302 04 40  
[direccion.ietcc@csic.es](mailto:direccion.ietcc@csic.es) <https://dit.ietcc.csic.es>

## European Technical Assessment

## ETA 20/0830 of 23/10/2023

English translation prepared by IETcc. Original version in Spanish language

### General Part

**Technical Assessment Body issuing the ETA designated according to Art. 29 of Regulation (EU) 305/2011:**

Instituto de Ciencias de la Construcción Eduardo Torroja (IETcc)

**Trade name of the construction product:**

**Connettore CentroStorico Calcestruzzo concrete screw**

**Product family to which the construction product belongs:**

Concrete screw of sizes 7.5, 10.5 and 12.5 for use in cracked and non-cracked concrete.

**Manufacturer:**

**LATERLITE S.P.A.  
Via Vittorio Veneto, 30  
43046 – Rubbiano di solignano (PR)  
ITALY**

**Manufacturing plants:**

**Laterlite S.p.A.  
Manufactory Plant J**

**This European Technical Assessment contains:**

16 pages including 4 annexes which form an integral part of this assessment.

**This European Technical Assessment is issued in accordance with regulation (EU) No 305/2011, on the basis of:**

European Technical Assessment EAD 330232-01-0601 "Mechanical Fasteners for use in concrete", ed. December 2019

**This ETA replaces:**

ETA 20/0830 version 1 issued on 28/05/2021



*English translation prepared by IETcc*

This European Technical Assessment is issued by the Technical Assessment Body in its official language. Translations of this European Technical Assessment in other languages shall fully correspond to the original issued document and should be identified as such.

This European Technical Assessment may be withdrawn by the issuing Technical Assessment Body, in particular pursuant to information by the Commission according to article 25 (3) of Regulation (EU) No 305/2011.

Código seguro de Verificación : GEN-020f-ad07-d954-a4a0-95d0-d0f8-560f-2fe2 | Puede verificar la integridad de este documento en la siguiente dirección : <https://portafirmas.redsara.es/pf/valida>

---

CSV : GEN-020f-ad07-d954-a4a0-95d0-d0f8-560f-2fe2

DIRECCIÓN DE VALIDACIÓN : <https://portafirmas.redsara.es/pf/valida>

FIRMANTE(1) : ANGEL CASTILLO TALAVERA | FECHA : 08/11/2023 11:32 | Sin acción específica



## SPECIFIC PART

### 1. Technical description of the product

The **Connettore CentroStorico Calcestruzzo** concrete screw is a type of anchor made of carbon steel. The anchor is made of carbon steel for sizes 7.5, 10.5 and 12.5. They are screwed into a predrilled cylindrical drill hole. The special thread of the anchor cuts an internal thread into the member while setting. The anchorage is characterised by mechanical interlock in the special thread.

The product and its installation description are shown in annexes A.

### 2. Specification of the intended use in accordance with the applicable European Assessment Document.

The performances given in section 3 are only valid if the anchor is used in compliance with the specifications and conditions given in annex B.

The verifications and assessment methods on which this European Technical Assessment is based lead to the assumption of a working life of the anchor of at least 50 years. The indications given on the working life cannot be interpreted as a guarantee given by the producer, but are to be regarded only as a means to choosing the right products in relation to the expected economically reasonable working life of the works.

### 3. Performance of the product and references to the methods used for its assessment

#### 3.1 Mechanical resistance and stability (BWR 1)

Essential characteristic	Performance
Static or quasi static actions	See annexes C1 to C3
Essential characteristic and displacements for seismic performance categories C1 and C2	See annexes C3 and C4

#### 3.2 Safety in case of fire (BWR 2)

Essential characteristic	Performance
Reaction to fire	Anchorage satisfy requirements for class A1
Resistance to fire	See annex D

### 4. Assessment and verification of constancy of performance (hereinafter AVCP) system applied, with reference to its legal base

The applicable European legal act for the system of Assessment and Verification of Constancy of Performances (see annex V of Regulation (EU) No 305/2011) is 96/582/EC.

The system to be applied is 1.



**5. Technical details necessary for the implementation of the AVCP system, as provided for in the applicable European Assessment Document.**

The technical details necessary for the implementation of the AVCP system are laid down in the quality plan deposited at Instituto de Ciencias de la Construcción Eduardo Torroja.



Instituto de Ciencias de la Construcción Eduardo Torroja  
CONSEJO SUPERIOR DE INVESTIGACIONES CIENTÍFICAS





C/ Serrano Galvache n.º 4. 28033 Madrid.  
Tel: (+34) 91 302 04 40  
<https://dit.ietcc.csic.es>



On behalf of the Instituto de Ciencias de la Construcción Eduardo Torroja  
Madrid, 23<sup>th</sup> of October 2023

Mr. Ángel Castillo Talavera  
Director IETcc - CSIC



<b>Product and identification</b>		
		CS-W
		CSC
<p>Marking/Identification on anchor:</p> <ul style="list-style-type: none"> <li>• Company logo</li> <li>• Outer diameter</li> <li>• Length</li> <li>• Anchor type: <ul style="list-style-type: none"> <li>- Hex head with washer CS-W</li> <li>- Hexagon head with bevelled shoulder CS-C</li> </ul> </li> </ul>		
<p><b>CONNETTORE CENTROSTORICO CALCESTRUZZO concrete screw</b></p>		<b>Annex A1</b>
<p><b>Product description</b></p>		
<p>Identification</p>		



English translation prepared by IETcc

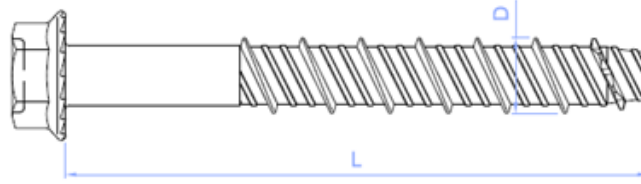

Head marking:  
Identifying mark of producer: LATERLITE  
Drill Diameter e.g. D=10  
Thread Length: e.g. 60 mm  
Material: Carbon Steel

**Table A1: Materials**

Item	Designation	CONNETTORE CENTROSTORICO CALCESTRUZZO concrete screw
1	Anchor Body	Carbon steel wire rod cold forged. Allowed coatings: <ul style="list-style-type: none"> <li>• Zinc plated <math>\geq 5 \mu\text{m}</math> ISO 4042 Zn5</li> <li>• Silver ruspert 1000/2000hours ISO9227</li> <li>• Zinc flake <math>\geq 5 \mu\text{m}</math> EN 10683</li> <li>• Mechanical plated <math>\geq 30 \mu\text{m}</math> EN ISO 12683 Zn 40 M(Fe)</li> </ul>

**CONNETTORE CENTROSTORICO CALCESTRUZZO concrete screw**

**Product description**

Identification and materials

**Annex A2**



**Installed condition**

- $h_{ef}$ : Effective anchorage depth
- $h_1$ : Depth of drilled hole
- $h_{nom}$ : Overall anchor embedment depth in the concrete
- $h_{min}$ : Minimum thickness of concrete member
- $t_{fix}$ : Thickness of fixture
- $d_0$ : Nominal diameter of drill bit
- $d_f$ : Diameter of clearance hole in fixture
- $t_{fix}$ : Fixture thickness

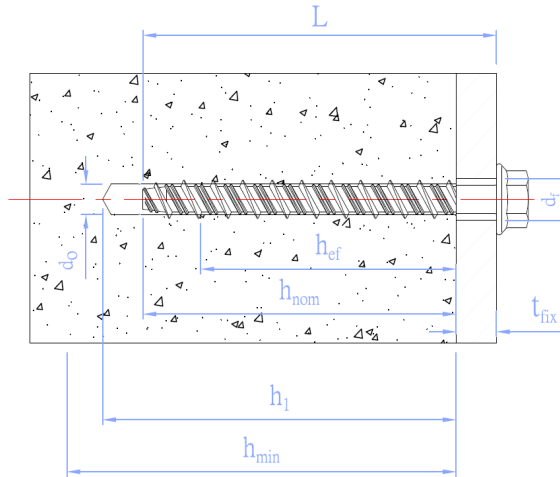

**Drawing A1.** Installed condition for anchors CS-W and CS-C

<p><b>CONNETTORE CENTROSTORICO CALCESTRUZZO concrete screw</b></p>	<p><b>Annex A3</b></p>
<p><b>Product description</b></p>	
<p>Installed condition</p>	



**Specification of intended use**

**Anchorage subjected to:**

- Static or quasi static loads: all sizes and embedment depths.
- Fire exposure up to 120 minutes
- Performances C1 and C2 (seismic) as shown below:

Size	7.5	10.5
$h_{nom}$	55	60
C1	✓	✓
C2		✓

**Base materials:**

- Reinforced and unreinforced normal weight concrete without fibers according to EN 206:2013 + A1:2016.
- Strength classes C20/25 to C50/60 according to EN 206:2013 + A1:2016.
- Cracked and uncracked concrete.

**Use conditions (environmental conditions):**

- The anchor shall be used in dry internal conditions.
- The anchor may be used for anchorages with requirements related to resistance to fire.

**Design:**

- Anchorages are designed under the responsibility of an engineer experienced in anchorages and concrete.
- Verifiable calculation rules and drawings are prepared taking into account of the loads to be attached. The position of the anchor is indicated on the design drawings (e.g. position of the anchor relative to reinforcement or to supports, etc.)
- Anchorages under static or quasi-static loads are designed for design Method A in accordance with EN 1992-4:2018
- Anchorages under seismic actions are designed in accordance with EN 1992-4:2018. Anchorages shall be positioned outside of critical regions (e.g. plastic hinges) of the concrete structure. Fastening in stand-off installation or with grout layer are not allowed.
- Anchorages under fire exposure are designed in accordance with EN 1992-4:2018. It must be ensured that local spalling of the concrete cover does not occur.
- Shear assessment only covers the shear force induced by the fixed piece, i.e. the piece located between the anchor head and the concrete block (piece contained in  $t_{fix}$ , see Drawing A1).

**CONNETTORE CENTROSTORICO CALCESTRUZZO concrete screw**

**Intended use**

Specifications

**Annex B1**





**Installation:**

- Hammer drilling only.
- Anchor installation carried out by appropriately qualified personal and under the supervision of the person responsible for technical matters of the site.
- In case of aborted hole: new drilling at a minimum distance away of twice the depth of aborted hole or smaller distance if the aborted hole is filled with high strength mortar and if under shear or oblique tension load it is not the direction of the load application.
- After installation further turning of the anchor is not possible.
- The head of the anchor is supported on the fixture, as it is shown in Drawing A1, and it must not be damaged.

**Installation process**

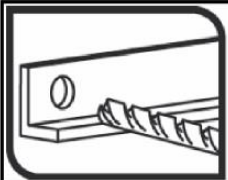
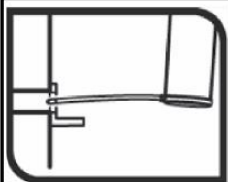
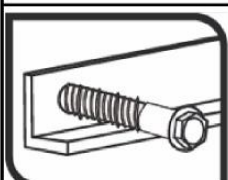
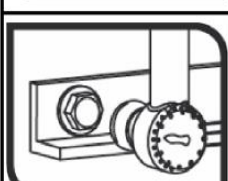
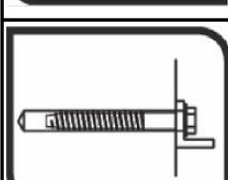
	<p><b>1. DRILL</b> Drill a hole into the base material of correct diameter and depth by using a carbide drill bit in rotary plus hammer mode.</p>
	<p><b>2. BLOW and CLEAN</b> Remove dust and debris from hole and loose particles left from drilling by using hand pump, compressed air or vacuum.</p>
	<p><b>3. INSTALL</b> Hold screw anchor perpendicular direction into the base material through fixtures.</p>
	<p><b>4. APPLY TORQUE</b> Select a power impact wrench or a torque wrench (e.g: Bosch GDS 18E, power input: 500 W; torque: 50-250 Nm). Power impact wrench does not exceed over torque Tinst.</p>
	<p><b>5. CHECK</b> The head must be undamaged and in contact with the fixture. When screw head attach fixture or concrete surface firmly, further turning of the head is unnecessary.</p>

**CONNETTORE CENTROSTORICO CALCESTRUZZO concrete screw**

**Intended use**

Specifications and installation procedure

**Annex B2**



**Table B1: Installation parameters**

Installation parameters		Performance		
		7.5	10.5	12.5
$h_{nom}$	Overall anchor embedment depth in the concrete: [mm]	55	60	70
$d_0$	Nominal diameter of drill bit: [mm]	6	8	10
$d_f$	Diameter of clearance hole in fixture: [mm]	9	12	14
$d_s$	Outer diameter of the thread: [mm]	7.5	10.5	12.5
$d_k$	Core diameter: [mm]	5.4	7.2	9.0
$h_{min}$	Minimum thickness of concrete member: [mm]	80	100	105
$h_1$	Depth of drilled hole: [mm]	65	70	85
$h_{ef}$	Effective anchorage depth: [mm]	42	45	52
$T_{ins}$	Installation torque: [Nm]	15	25	50
$t_{fix}$	Thickness of fixture <sup>1)</sup> : [mm]	L-55	L-60	L-70
$s_{min}$	Minimum allowable spacing: [mm]	50	45	60
$c_{min}$	Minimum allowable edge distance: [mm]	35	45	60

<sup>1)</sup> L = Total length of the fastener

**CONNETTORE CENTROSTORICO CALCESTRUZZO concrete screw**

**Performances**

Installation parameters

**Annex B3**



**Table C1: Characteristic values to tension loads**

Characteristic values of resistance to tension loads of design method A		Performance		
		7.5	10.5	12.5
$h_{nom}$	Overall anchor embedment depth in the concrete: [mm]	55	60	70
<b>Tension loads: steel failure</b>				
$N_{Rk,s}$	Tension steel characteristic resistance: [kN]	18.7	32.7	51.2
$\gamma_{Ms}$	Partial safety factor: <sup>1)</sup> [-]	1.5	1.5	1.5
<b>Tension loads: pull-out failure in concrete</b>				
$N_{Rk,p,ucr}$	Tension characteristic resistance in C20/25 uncracked concrete: [kN]	9.0	12.0 <sup>2)</sup>	20.0 <sup>2)</sup>
$N_{Rk,p,cr}$	Tension characteristic resistance in C20/25 cracked concrete: [kN]	6.0	9.0	12.0
$\psi_c$	C30/37 [-]	1.22	1.08	1.04
$\psi_c$	C40/45 [-]	1.41	1.15	1.07
$\psi_c$	C50/60 [-]	1.55	1.19	1.09
<b>Tension loads: concrete cone and splitting failure</b>				
$\gamma_{ins}$	Installation safety factor: <sup>1)</sup> [-]	1.2	1.2	1.2
$h_{ef}$	Effective embedment depth: [mm]	42	45	52
$k_{ucr,N}$	Factor for uncracked concrete: [-]	11.0		
$N^0_{Rk,c,ucr}$	Tension characteristic resistance in C20/25 uncracked concrete: <sup>3)</sup> [kN]	13.4	14.8	18.4
$k_{cr,N}$	Factor for cracked concrete: [-]	7.7		
$N^0_{Rk,c,cr}$	Tension characteristic resistance in C20/25 cracked concrete: <sup>3)</sup> [kN]	9.4	10.4	12.9
$s_{cr,N}$	Critical spacing: [mm]	3.0 x $h_{ef}$		
$c_{cr,N}$	Critical edge distance: [mm]	1.5 x $h_{ef}$		
$s_{cr,sp}$	Critical spacing (splitting): [mm]	3.0 x $h_{ef}$		
$c_{cr,sp}$	Critical edge distance (splitting): [mm]	1.5 x $h_{ef}$		

<sup>1)</sup> In absence of other national regulations

<sup>2)</sup> Pull-out failure is not decisive ( $N^0_{Rk,c} < N_{Rk,p}$ )

<sup>3)</sup> Equation 7.2 from EN 1992-4:2018

**CONNETTORE CENTROSTORICO CALCESTRUZZO concrete screw**

**Performances**

Characteristic values for tension loads

**Annex C1**



**Table C2: Displacements under tension loads**

Characteristic values of displacements under tension loads of design method A		Performance		
		7.5	10.5	12.5
$h_{nom}$	Overall anchor embedment depth in the concrete: [mm]	55	60	70
<b>Displacements under tension loads in uncracked concrete</b>				
N	Service tension load in uncracked concrete C20/25 to C50/60: [kN]	3.6	4.8	9.5
$\delta_{N0}$	Short term displacement under tension loads: [mm]	0.40	0.40	0.40
$\delta_{N\infty}$	Long term displacement under tension loads: [mm]	1.00	1.10	1.40
<b>Displacements under tension loads in cracked concrete</b>				
N	Service tension load in cracked concrete C20/25 to C50/60: [kN]	2.4	3.6	5.7
$\delta_{N0}$	Short term displacement under tension loads: [mm]	0.60	0.70	0.50
$\delta_{N\infty}$	Long term displacement under tension loads: [mm]	1.40	1.20	1.40

**Table C3: Characteristic values to shear loads**

Characteristic values of resistance to shear loads		Performance		
		7.5	10.5	12.5
$h_{nom}$	Overall anchor embedment depth in the concrete: [mm]	55	60	70
<b>Shear loads: steel failure without lever arm</b>				
$V_{Rk,s}$	Shear steel characteristic resistance: [kN]	7.5	16.3	25.6
$k_7$	$k_7$ factor: <sup>1)</sup> [-]	0.8	0.8	0.8
$\gamma_{Ms}$	Partial safety factor: <sup>2)</sup> [-]	1.25	1.25	1.25
<b>Shear loads: steel failure with lever arm</b>				
$M^0_{Rk,s}$	Characteristic bending moment: [Nm]	15.2	35.3	69.3
$\gamma_{Ms}$	Partial safety factor: <sup>2)</sup> [-]	1.25	1.25	1.25
<b>Shear loads: concrete pryout failure</b>				
$k_8$	$k_8$ factor: [-]	1.0	1.0	1.0
$\gamma_{inst}$	Installation safety factor: <sup>2)</sup> [-]	1.0	1.0	1.0
<b>Shear loads: concrete edge failure</b>				
$l_f$	Effective anchorage depth under shear loads: [mm]	42	45	52
$d_{nom}$	Nominal outer diameter of screw: [mm]	6	8	10
$\gamma_{inst}$	Installation safety factor: <sup>2)</sup> [-]	1.0	1.0	1.0

<sup>1)</sup> The diameter of the clearance hole does not meet the values given in EN 1992-4 Table 6.1. However, the group resistance under shear loading has been verified in the assessment through testing and accounted for in the factor  $k_7$ .

<sup>2)</sup> In absence of other national regulations.

**CONNETTORE CENTROSTORICO CALCESTRUZZO concrete screw**

**Performances**

Displacement under tension loads  
Characteristic values to shear loads

**Annex C2**



**Table C4: Displacements under shear loads**

Characteristic values of displacements under shear loads of design method A		Performances		
		7.5	10.5	12.5
$h_{nom}$	Overall anchor embedment depth in the concrete: [mm]	55	60	70
<b>Displacements under shear loads in uncracked concrete</b>				
$V$	Service shear load in uncracked concrete C20/25 to C50/60: [kN]	3.6	4.8	9.5
$\delta_{V0}$	Short term displacement under shear loads: [mm]	0.4	0.40	0.40
$\delta_{V\infty}$	Long term displacement under shear loads: [mm]	1.0	1.10	1.40
<b>Displacements under shear loads in cracked concrete</b>				
$V$	Service shear load in cracked concrete C20/25 to C50/60: [kN]	2.4	3.6	5.7
$\delta_{V0}$	Short term displacement under shear loads: [mm]	0.60	0.70	0.50
$\delta_{V\infty}$	Long term displacement under shear loads: [mm]	1.40	1.20	1.40

**Table C5: Essential characteristics for seismic performance category C1**

Essential characteristics for seismic performance category C1		Performances	
		7.5	10.5
$h_{nom}$	Overall anchor embedment depth in the concrete: [mm]	55	60
<b>Steel failure for tension and shear loads</b>			
$N_{Rk,s,C1}$	Characteristic resistance: [kN]	18.7	32.7
$\gamma_{Ms}$	Partial safety factor <sup>1)</sup> : [--]	1.5	1.5
$V_{Rk,s,C1}$	Characteristic resistance: [kN]	7.5	16.3
$\gamma_{Ms}$	Partial safety factor <sup>1)</sup> : [--]	1.25	1.25
<b>Pull out failure</b>			
$N_{Rk,p,C1}$	Characteristic resistance in cracked concrete: [kN]	5.6	9.0
$\gamma_{inst}$	Robustness: [--]	1.2	1.2
<b>Concrete cone failure</b>			
$h_{ef}$	Effective embedment depth: [mm]	42	45
$s_{cr,N}$	Concrete Spacing: [mm]	126	135
$c_{cr,N}$	cone failure Edge distance: [mm]	63	67
$\gamma_{inst}$	Installation safety factor: [--]	1.2	1.2
<b>Concrete pry-out failure</b>			
$k_s$	Pry-out factor: [--]	1.0	1.0
$\gamma_{inst}$	Installation safety factor: [--]	1.0	1.0
<b>Concrete edge failure</b>			
$l_f = h_{ef}$	Effective length of fastener under shear loads: [mm]	42	45
$d_{nom}$	Nominal outer diameter of screw: [mm]	6	8
$\gamma_{inst}$	Installation safety factor: [--]	1.0	1.0

<sup>1)</sup> In absence of other national regulations

**CONNETTORE CENTROSTORICO CALCESTRUZZO concrete screw**

**Performances**

Displacements under shear loads  
Essential characteristics for seismic performance category C1

**Annex C3**



**Table C6: Essential characteristics for seismic performance category C2**

Essential characteristics for seismic performance category C2			Performances
			10.5
$h_{nom}$	Overall anchor embedment depth in the concrete:	[mm]	60
<b>Steel failure for tension and shear loads</b>			
$N_{Rk,s,C2}$	Characteristic resistance:	[kN]	32.7
$\gamma_{Ms}$	Partial safety factor <sup>1)</sup> :	[-]	1.5
$V_{Rk,s,C2}$	Characteristic resistance:	[kN]	13.7
$\gamma_{Ms}$	Partial safety factor <sup>1)</sup> :	[-]	1.25
<b>Pull out failure</b>			
$N_{Rk,p,C2}$	Characteristic resistance in cracked concrete:	[kN]	5.2
$\gamma_{inst}$	Robustness:	[-]	1.2
<b>Concrete cone failure</b>			
$h_{ef}$	Effective embedment depth:	[mm]	45
$s_{cr,N}$	Concrete Spacing:	[mm]	135
$c_{cr,N}$	cone failure Edge distance:	[mm]	68
$\gamma_{inst}$	Installation safety factor:	[-]	1.2
<b>Concrete pry-out failure</b>			
$k_B$	Pry-out factor:	[-]	1.0
$\gamma_{inst}$	Installation safety factor:	[-]	1.0
<b>Concrete edge failure</b>			
$l_f = h_{ef}$	Effective length of fastener under shear loads:	[mm]	45
$d_{nom}$	Nominal outer diameter of screw:	[mm]	8.0
$\gamma_{inst}$	Installation safety factor:	[-]	1.0
<b>Displacements</b>			
$\bar{\Delta}_{N,C2}$ (DLS)	Displacement at	[mm]	0.15
$\bar{\Delta}_{V,C2}$ (DLS)	Damage Limitation State: <sup>2)</sup>	[mm]	4.15
$\bar{\Delta}_{N,C2}$ (ULS)	Displacement at	[mm]	1.41
$\bar{\Delta}_{V,C2}$ (ULS)	Ultimate Limitation State: <sup>2)</sup>	[mm]	8.27

DLS: Damage Limitation State: see EN 1992-4, 2.2.1)

ULS: Ultimate Limitation State: see EN 1992-4 2.2.1)

<sup>1)</sup> In absence of other national regulations.

<sup>2)</sup> The listed displacements represent mean values.

**CONNETTORE CENTROSTORICO CALCESTRUZZO concrete screw**

**Performances**

Essential characteristics for seismic performance category C2

**Annex C4**



**Table D1: Characteristic values to fire resistance**

Fire resistance duration = 30 minutes		Performances		
		7.5	10.5	12.5
$h_{nom}$	Overall anchor embedment depth in the concrete: [mm]	55	60	70
<b>Tension loads, steel failure</b>				
$N_{Rk,s,fi,30}$	Characteristic resistance: [kN]	0.23	0.41	0.95
<b>Pull-out failure</b>				
$N_{Rk,p,fi,30}$	Character. resistance in concrete: [kN]	1.43	2.28	3.60
<b>Concrete cone failure <sup>1)</sup></b>				
$N_{Rk,c,fi,30}$	Character. resistance in concrete: [kN]	1.97	2.34	3.36
<b>Shear loads steel failure without lever arm</b>				
$V_{Rk,s,fi,30}$	Characteristic resistance [kN]	0.23	0.41	0.95
<b>Shear loads, steel failure with lever arm</b>				
$M_{Rk,s,fi,30}$	Characteristic bending resistance: [Nm]	0.19	0.44	1.29

Fire resistance duration = 60 minutes		Performances		
		7.5	10.5	12.5
$h_{nom}$	Overall anchor embedment depth in the concrete: [mm]	55	60	70
<b>Tension loads, steel failure</b>				
$N_{Rk,s,fi,30}$	Characteristic resistance: [kN]	0.21	0.37	0.83
<b>Pull-out failure</b>				
$N_{Rk,p,fi,30}$	Character. resistance in concrete: [kN]	1.43	2.28	3.60
<b>Concrete cone failure <sup>1)</sup></b>				
$N_{Rk,c,fi,30}$	Character. resistance in concrete: [kN]	1.97	2.34	3.36
<b>Shear loads steel failure without lever arm</b>				
$V_{Rk,s,fi,30}$	Characteristic resistance [kN]	0.21	0.37	0.83
<b>Shear loads, steel failure with lever arm</b>				
$M_{Rk,s,fi,30}$	Characteristic bending resistance: [Nm]	0.17	0.40	1.12

<sup>1)</sup> As a rule, splitting failure can be neglected when cracked concrete and reinforcement is assumed.

Note: In absence of other national regulations, the partial safety factor for resistance under fire exposure  $\gamma_{M,fi} = 1.0$  is recommended for steel failure and concrete related failure modes under shear loading. In case of concrete related failure modes under tension  $\gamma_{M,fi} = \gamma_{inst.}$

**CONNETTORE CENTROSTORICO CALCESTRUZZO concrete screw**

**Performances**  
Characteristic values for fire resistance

**Annex D1**



**Table D1: Characteristic values to fire resistance (continuation)**

Fire resistance duration = 90 minutes		Performances		
		7.5	10.5	12.5
$h_{nom}$	Overall anchor embedment depth [mm] in the concrete:	55	60	70
<b>Tension loads, steel failure</b>				
$N_{Rk,s,fi,30}$	Characteristic resistance: [kN]	0.16	0.29	0.64
<b>Pull-out failure</b>				
$N_{Rk,p,fi,30}$	Character. resistance in concrete: [kN]	1.43	2.28	3.60
<b>Concrete cone failure <sup>1)</sup></b>				
$N_{Rk,c,fi,30}$	Character. resistance in concrete: [kN]	1.97	2.34	3.36
<b>Shear loads steel failure without lever arm</b>				
$V_{Rk,s,fi,30}$	Characteristic resistance [kN]	0.16	0.29	0.64
<b>Shear loads, steel failure with lever arm</b>				
$M_{Rk,s,fi,30}$	Characteristic bending resistance: [Nm]	0.13	0.31	0.86

Fire resistance duration = 120 minutes		Performances		
		7.5	10.5	12.5
$h_{nom}$	Overall anchor embedment depth [mm] in the concrete:	55	60	70
<b>Tension loads, steel failure</b>				
$N_{Rk,s,fi,30}$	Characteristic resistance: [kN]	0.11	0.20	0.51
<b>Pull-out failure</b>				
$N_{Rk,p,fi,30}$	Character. resistance in concrete: [kN]	1.14	1.82	2.88
<b>Concrete cone failure <sup>1)</sup></b>				
$N_{Rk,c,fi,30}$	Character. resistance in concrete: [kN]	1.57	1.87	2.69
<b>Shear loads steel failure without lever arm</b>				
$V_{Rk,s,fi,30}$	Characteristic resistance [kN]	0.11	0.20	0.51
<b>Shear loads, steel failure with lever arm</b>				
$M_{Rk,s,fi,30}$	Characteristic bending resistance: [Nm]	0.09	0.22	0.69

<sup>1)</sup> As a rule, splitting failure can be neglected when cracked concrete and reinforcement is assumed.

Note: In absence of other national regulations, the partial safety factor for resistance under fire exposure  $\gamma_{M,fi} = 1.0$  is recommended for steel failure and concrete related failure modes under shear loading. In case of concrete related failure modes under tension  $\gamma_{M,fi} = \gamma_{inst.}$

**CONNETTORE CENTROSTORICO CALCESTRUZZO concrete screw**

**Performances**  
Characteristic values for fire resistance

**Annex D2**





**Table D2: Spacing and edge distances**

Spacing and edge distances			Performances		
			7.5	10.5	12.5
$h_{nom}$	Overall anchor embedment depth in the concrete:	[mm]	55	60	70
$h_{ef}$	Effective anchorage depth:	[mm]	42	45	52
$S_{cr,N}$	Spacing	[mm]	168	180	208
$S_{min}$	Minimum spacing	[mm]	45	50	60
$C_{cr,N}$	Edge distance	[mm]	84	90	104
$C_{min}$	Minimum edge distance (one side fire)	[mm]	45	50	60
$C_{min}$	Minimum edge distance (two sides fire)	[mm]	300	300	300
$\gamma_{Msp}$	Partial safety factor <sup>*)</sup>	[-]	1.0	1.0	1.0

\*) In absence of other national regulations

**Concrete pry-out failure**

$k_8$  factor values for Concrete Screw in Table C5  
According EN 1992-4:2018, these values of  $k_8$  factor and the relevant values of  $N_{Rk,c,fi}$  given in the above tables have to be considered in design.

**Concrete edge failure**

The characteristic resistance  $V^0_{Rk,c,fi}$  in C20/25 to C50/60 concrete is determined by:  
 $V^0_{Rk,c,fi} = 0.25 \times V^0_{Rk,c} (\leq R90)$  and  $V^0_{Rk,c,fi} = 0.20 \times V^0_{Rk,c} (R120)$   
With  $V^0_{Rk,c}$  initial value of the characteristic resistance in cracked concrete C20/25 under normal temperature according to EN 1992-4:2018.

**CONNETTORE CENTROSTORICO CALCESTRUZZO concrete screw**

**Performances**  
Spacing and edge distances

**Annex D3**

