



**INSTITUTO DE CIENCIAS
DE LA CONSTRUCCIÓN
EDUARDO TORROJA**

C/ Serrano Galvache n. 4 28033 Madrid (Spain)
Tel.: (34) 91 302 04 40 Fax: (34) 91 302 07 00
direccion.ietcc@csic.es <https://dit.ietcc.csic.es>

European Technical Assessment

**ETA 22/0449
of 08/09/2022**

English translation prepared by IETcc. Original version in Spanish language

General Part

Technical Assessment Body issuing the ETA designated according to Art. 29 of Regulation (EU) 305/2011:

Instituto de Ciencias de la Construcción Eduardo Torroja (IETcc)

Trade name of the construction product:

TP DA+, TP DAL+, TP DA-A4+, TP DAS+ drop in anchor

Product family to which the construction product belongs:

Deformation controlled anchor made of galvanized steel or stainless steel or stainless steel of sizes M6, M8, M10, M12, M16 and M20 for use in concrete for redundant non-structural systems

Manufacturer:

Team Pro International FZ-LLC
Ras Al Khaimah
P.O. Box 41010
United Arab Emirates.
website: www.team-pro.com

Manufacturing plant:

Team Pro Factory A

This European Technical Assessment contains:

15 pages including 3 annexes which form an integral part of this assessment.

This European Technical Assessment is issued in accordance with regulation (EU) No 305/2011, on the basis of:

European Assessment Document EAD 330747-00-0601, "Fasteners for use in concrete for redundant non-structural systems", ed. May 2018.

English translation prepared by IETcc

This European Technical Assessment is issued by the Technical Assessment Body in its official language. Translations of this European Technical Assessment in other languages shall fully correspond to the original issued document and should be identified as such.

This European Technical Assessment may be withdrawn by the issuing Technical Assessment Body, in particular pursuant to information by the Commission according to article 25 (3) of Regulation (EU) No 305/2011.

English translation prepared by IETcc

SPECIFIC PART

1. Technical description of the product

The Team Pro TP DA+, TP DAL+, TP DAS+, in the range of M6 to M20, is an anchor made of galvanised steel. The Team Pro TP DA-A4+ in the range of M6 to M20, is an anchor made of stainless steel. They are placed into a drilled hole and anchored by deformation-controlled expansion. The anchorage is characterised by friction between the sleeve and concrete.

Product and installation descriptions are given in annexes A1 and A2.

2. Specification of the intended use in accordance with the applicable European Assessment Document

The performances given in section 3 are only valid if the anchor is used in compliance with the specifications and conditions given in annex B.

The verifications and assessment methods on which this European Technical Assessment is based lead to the assumption of a working life of the anchor of at least 50 years. The indications given on the working life cannot be interpreted as a guarantee given by the producer, but are to be regarded only as a mean to choosing the right products in relation to the expected economically reasonable working life of the works.

3. Performance of the product and references to the methods used for its assessment

3.1 Safety in case of fire (BWR 2)

Essential characteristic	Performance
Reaction to fire	Anchorage satisfies requirements for class A1 according to EN 13501-1
Resistance to fire	See annex C7

3.2 Safety in use (BWR 4)

Essential characteristic	Performance
Essential characteristics under static or quasi static loading	See annexes C3 to C6

4. Assessment and Verification of Constancy of Performances (hereinafter AVCP) system applied, with reference to its legal base

The applicable European legal act for the system of Assessment and Verification of Constancy of Performances (see annex V to Regulation (EU) No 305/2011) is 97/161/EC.

The system to be applied is 2+.

English translation prepared by IETcc

5. Technical details necessary for the implementation of the AVCP system, as provided for in the applicable European Assessment Document

The technical details necessary for the implementation of the AVCP system are laid down in the quality plan deposited at Instituto de Ciencias de la Construcción Eduardo Torroja.



Instituto de Ciencias de la Construcción Eduardo Torroja
CONSEJO SUPERIOR DE INVESTIGACIONES CIENTÍFICAS

C/ Serrano Galvache n.º 4. 28033 Madrid.
Tel: (+34) 91 302 04 40 Fax. (+34) 91 302 07 00

<https://dit.ietcc.csic.es>



On behalf of the Instituto de Ciencias de la Construcción Eduardo Torroja
Madrid, 8th of September 2022

Director IETcc - CSIC



English translation prepared by IETcc

Product



TP DA+ anchor



TP DAL+ anchor



TP DAS+ anchor



TP DA-A4+ anchor

Identification on sleeve: Team Pro logo + “TP DA+ (TP DAL+, TP DAS+, TP DA-A4+)” + Metric;

Table A1: Dimensions

Anchor dimensions	M6	M8	M10	M12	M12D	M16	M20	
TP DA+, TP DAL+								
ØD: External diameter [mm]	8	10	12	15	16	20	25	
Ød: internal diameter [mm]	M6	M8	M10	M12	M12	M16	M20	
L: total length [mm]	25	30	40	50	50	65	80	
TP DAS+								
ØD: External diameter [mm]	--	10	12	15	--	--	--	
Ød: internal diameter [mm]	--	M8	M10	M12	--	--	--	
L: total length [mm]	--	25	25	25	--	--	--	
TP DA-A4+								
ØD: External diameter [mm]	8	10	12	15	--	20	25	
Ød: internal diameter [mm]	M6	M8	M10	M12	--	M16	M20	
L: total length [mm]	25	30	40	50	--	65	80	

Table A2: Materials

Item	Designation	Material for TP DA+, TP DAL+, TP DAS+	Material for TP DA-A4+
1	Sleeve	Carbon steel, zinc plated $\geq 5 \mu\text{m}$ ISO 4042 Zn5/An/T0	Stainless steel, grade A4
2	Cone	Carbon steel, zinc plated $\geq 5 \mu\text{m}$ ISO 4042 Zn5/An/T0	Stainless steel, grade A4
3	Retention disc	Plastic	Plastic

TP DA+, TP DAL+, TP DAS+, TP DA-A4+ anchor

Product description

Product and materials

Annex A1

English translation prepared by IETcc

Installed condition in concrete

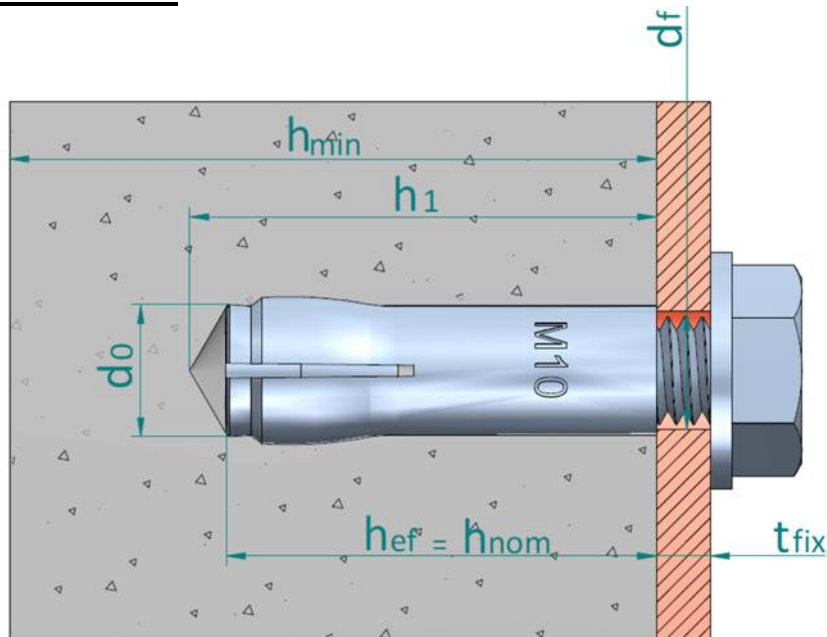

- h_{ef} : Effective anchorage depth
- h_1 : Depth of drilled hole
- h_{nom} : Overall anchor embedment depth in the concrete
- h_{min} : Minimum thickness of concrete member
- t_{fix} : Thickness of fixture
- d_0 : Nominal diameter of drill bit
- d_f : Fixture clearance hole diameter

Setting tool

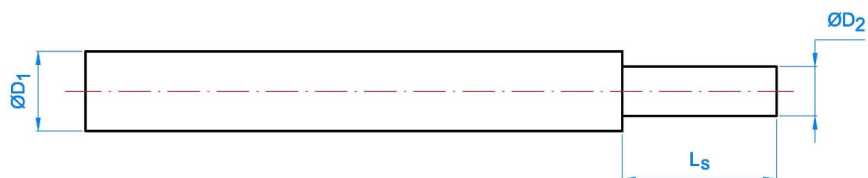

Setting tool can be assembled with a plastic handle for hand protection purposes

Table A3: Setting tool dimensions

Setting tool dimensions	M6	M8	M10	M12	M16	M20
TP DA+, TP DAL+, TP DA-A4+						
Ø D ₁ [mm]	8.0	10.0	12.0	15.0	20.0	25.0
Ø D ₂ [mm]	4.9	6.4	8.2	10.0	13.5	17.0
L _s [mm]	15.0	18.0	21.0	30.0	36.0	50.0
TP DAS+						
Ø D ₁ [mm]	--	10.0	12.0	15.0	--	--
Ø D ₂ [mm]	--	6,4	8,2	10,0	--	--
L _s [mm]	--	15.0	16.0	10.4	--	--

TP DA+, TP DAL+, TP DAS+, TP DA-A4+ anchor

Product description

Installed condition in concrete and setting tool

Annex A2

English translation prepared by IETcc

Installed condition in precast prestressed hollow core concrete slabs

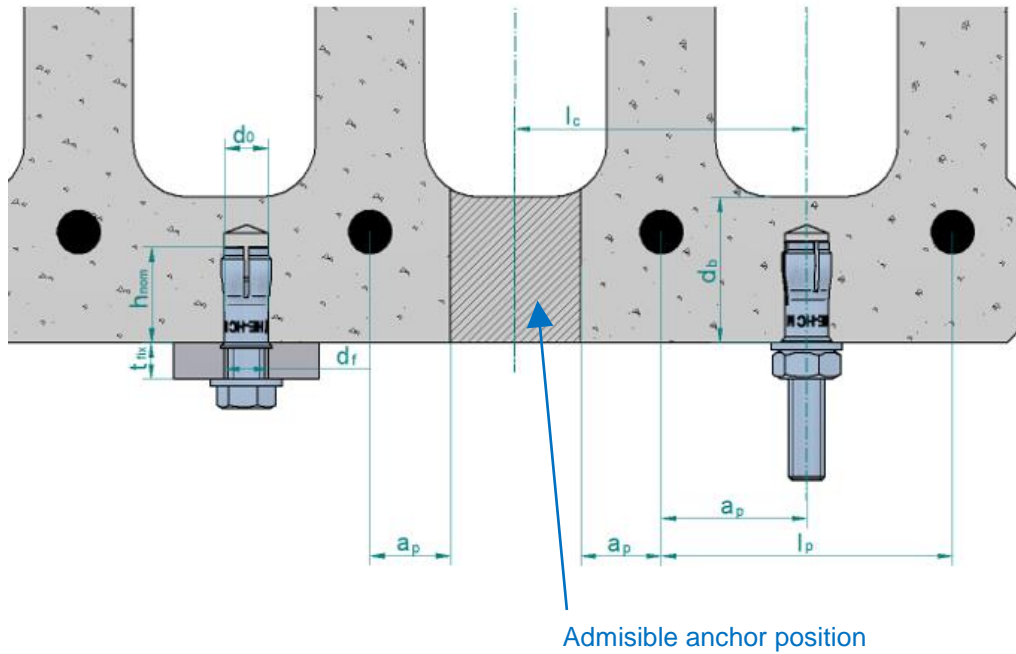

- d₀: Nominal diameter of drill bit
- d_f: Fixture clearance hole diameter
- d_b: Bottom flange thickness
- a_p: Distance between anchor position and prestressing steel ≥ 50 mm
- l_c: Core distance ≥ 100 mm
- l_p: Prestressing steel distance ≥ 100 mm
- t_{fix}: Fixture thickness
- c: Edge distance

TP DAS+ anchor	Annex A3
Product description	
Installed condition in precast prestressed hollow core concrete slabs	

Specifications of intended use

Anchorage subjected to:

- Static or quasi static loads for redundant non-structural systems.
- Use for anchorages with requirements related to resistance of fire (not for using in prestressed hollow core slabs).
- The anchor may only be used if in the design and installation specifications for the fixture the excessive slip or failure of one anchor will not result in a significant violation of the requirements on the fixture in the serviceability and ultimate state.

Base materials:

- Reinforced or unreinforced normal weight concrete without fibres according to EN 206-1:2013+A1:2016.
- Strength classes C12/15 to C50/60 according to EN 206-1:2013+A1:2016: TP DA+ / TP DAL+ anchors.
- Strength classes C20/25 to C50/60 according to EN 206-1:2013+A1:2016: TP DAS+ / TP DA-A4+ anchors.
- Cracked or uncracked concrete.
- Precast, prestressed hollow core concrete slabs, strength C30/37 to C50/60 according to EN 206:2013+A1:2016: TP DAS+.

Use conditions (environmental conditions):

- TP DA+, TP DAL+, TP DAS+: anchorages subjected to dry internal conditions.
- TP DA-A4+: anchorages subjected to dry internal conditions, to external atmospheric exposure (including industrial and marine environment) or to permanent internal damp conditions if no particular aggressive conditions exist. Such particular aggressive conditions are e.g. permanent, alternating immersion in seawater or the splash zone of seawater, chloride atmosphere of indoor swimming pools or atmosphere with extreme chemical pollution (e.g. in desulphurization plants or road tunnels where de-icing materials are used). Atmospheres under Corrosion Resistance Class CRC III according to EN 1993-1-4:2006+A1:2015 annex A.

Design:

- Anchorages are designed under the responsibility of an engineer experienced in anchorages and concrete.
- Verifiable calculation rules and drawings are prepared taking into account of the loads to be anchored. The position of the anchor is indicated on the design drawings (e.g. position of the anchor relative to reinforcement or to supports, etc.).
- Anchorages under static or quasi-static actions are designed for design method B in accordance with EN 1992-4:2018
- Anchorages under fire exposure are designed in accordance to EN 1992-4:2018. It must be ensured that local spalling of the concrete cover does not occur.

Installation:

- Hole drilling by rotary plus hammer mode.
- Anchor installation carried out by appropriately qualified personal and under the supervision of the person responsible for technical matters of the site.
- In case of aborted hole: new drilling at a minimum distance away of twice the depth of aborted hole or smaller distance if the aborted hole is filled with high strength mortar and if under shear or oblique tension load it is not the direction of the load application.
- TP DA+, TP DAL+, TP DAS+: the bolt or threaded rod to be used shall be property class 4.6, 5.6, 5.8, 6.8 or 8.8 according to ISO 898-1.
- TP DA-A4+: the bolt or threaded rod to be used shall be property class A4-50, A4-70 or A4-80 according to EN 3506-1:2009
- The length of the bolt shall be determined as:
 - Minimum bolt length = $t_{fix} + l_{s,min}$
 - Maximum bolt length = $t_{fix} + l_{s,max}$

TP DA+, TP DAL+, TP DAS+, TP DA-A4+ anchor	Annex B1
Intended use	
Specifications	

English translation prepared by IETcc

Table C1: Installation parameters in concrete for TP DA+, TP DAL+, TP DAS+, TP DA-A4+ anchor

Installation parameters			Performances						
			M6	M8	M10	M12	M12D	M16	M20
d ₀	Nominal diameter of drill bit:	[mm]	8	10	12	15	16	20	25
D	Thread diameter:	[mm]	M6	M8	M10	M12	M12	M16	M20
d _f	Fixture clearance hole diameter ≤	[mm]	7	9	12	14	14	18	22
T _{inst}	Maximum installation torque:	[Nm]	4	11	17	38	38	60	100
TP DA+, TP DAL+			M6x25 φ8	M8x30 φ10	M10x40 φ12	M12x50 φ15	M12x50 φ16	M16x65 φ20	M20x80 φ25
l _{s,min}	Minimum screwing depth:	[mm]	6	8	10	12	12	16	20
l _{s,max}	Maximum screwing depth:	[mm]	10	13	17	21	21	27	34
h ₁	Depth of drilled hole:	[mm]	27	33	43	54	54	70	86
h _{nom}	Overall anchor embedment depth:	[mm]	25	30	40	50	50	65	80
h _{ef}	Effective anchorage depth:	[mm]	25	30	40	50	50	65	80
h _{min}	Minimum thickness of concrete member:	[mm]	100	100	100	100	100	130	160
s _{min}	Minimum allowable spacing:	[mm]	60	60	80	100	100	130	160
c _{min}	Minimum allowable distance:	[mm]	105	105	140	175	130	230	280
TP DAS+			-	M8x25 φ10	M10x25 φ12	M12x25 φ15	-	-	-
l _{s,min}	Minimum screwing depth:	[mm]	--	7	8	10	--	--	--
l _{s,max}	Maximum screwing depth:	[mm]	--	12	13	13	--	--	--
h ₁	Depth of drilled hole:	[mm]	--	28	28	29	--	--	--
h _{nom}	Overall anchor embedment depth:	[mm]	--	25	25	25	--	--	--
h _{ef}	Effective anchorage depth:	[mm]	--	25	25	25	--	--	--
h _{min}	Minimum thickness of concrete member:	[mm]	--	80	80	80	--	--	--
s _{min}	Minimum allowable spacing:	[mm]	--	75	75	75	--	--	--
c _{min}	Minimum allowable distance:	[mm]	--	60	60	60	--	--	--
TP DA-A4+			M6x25 φ8	M8x30 φ10	M10x40 φ12	M12x50 φ15	-	M16x65 φ20	M20x80 φ25
l _{s,min}	Minimum screwing depth:	[mm]	6	8	10	12	--	16	20
l _{s,max}	Maximum screwing depth:	[mm]	10	13	17	21	--	27	34
h ₁	Depth of drilled hole:	[mm]	27	33	43	54	--	70	86
h _{nom}	Overall anchor embedment depth:	[mm]	25	30	40	50	--	65	80
h _{ef}	Effective anchorage depth:	[mm]	25	30	40	50	--	65	80
h _{min}	Minimum thickness of concrete member:	[mm]	80	80	80	100	--	130	160
s _{min}	Minimum allowable spacing:	[mm]	60	60	100	100	--	130	160
c _{min}	Minimum allowable distance:	[mm]	65	80	100	130	--	175	210

TP DA+, TP DAL+, TP DAS+, TP DA-A4+ anchor

Performances

Installation parameters in concrete

Annex C1

English translation prepared by IETcc

Table C2: Installation parameters in prestressed hollow core concrete slabs for TP DAS+ anchor

Installation parameters in prestressed hollow core concrete slabs			Performances						
			!	M8x25 φ10	M10x25 φ12	M12x25 φ15	!	!	!
TP DAS+			!	M8x25 φ10	M10x25 φ12	M12x25 φ15	!	!	!
$l_{s,min}$	Minimum screwing depth:	[mm]	--	7	8	10	--	--	--
$l_{s,max}$	Maximum screwing depth:	[mm]	--	12	13	13	--	--	--
h_1	Depth of drilled hole:	[mm]	--	28	28	29	--	--	--
h_{nom}	Overall anchor embedment depth:	[mm]	--	25	25	25	--	--	--
h_{ef}	Effective anchorage depth:	[mm]	--	25	25	25	--	--	--
d_b	Minimum bottom flange thickness	[mm]	--	35	35	35	--	--	--
s_{min}	Minimum allowable spacing:	[mm]	--	200	200	200	--	--	--
c_{min}	Minimum allowable distance:	[mm]	--	150	150	150	--	--	--

TP DAS+ anchor

Performances

Installation parameters in prestressed hollow core concrete slabs

Annex C2

English translation prepared by IETcc

Installation process

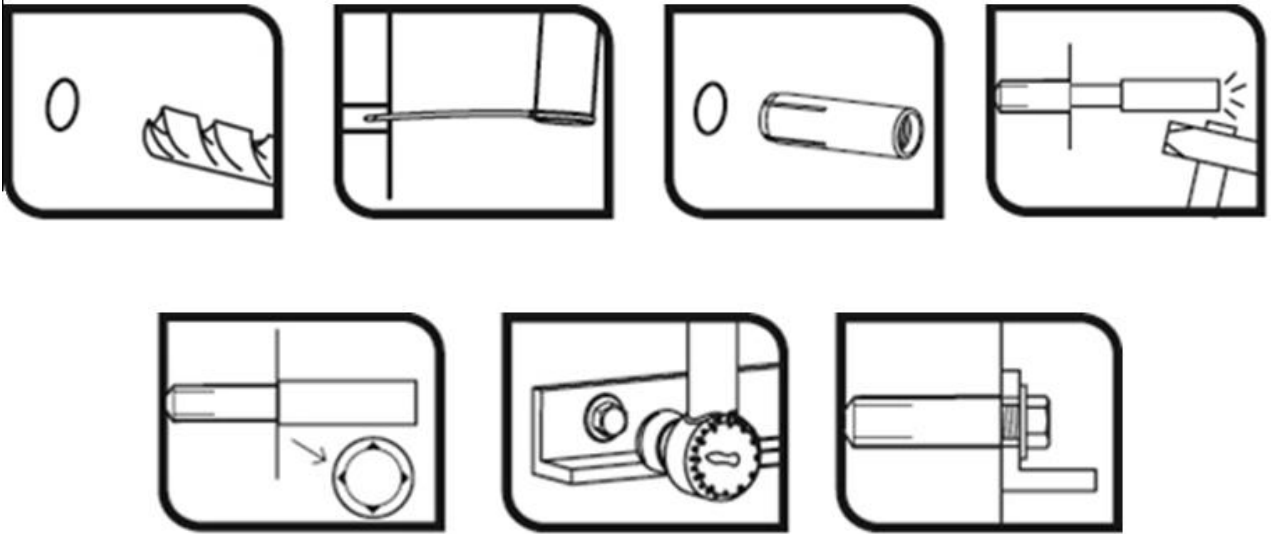

TP DA+, TP DAL+, TP DAS+, TP DA-A4+ anchor

Performances

Installation procedure

Annex C3

English translation prepared by IETcc

Table C3: Essential characteristics in concrete to loads of design method B according to EN 1992-4 for TP DA+, TP DAL+, TP DAS+ anchor

Essential characteristics of resistance to loads of design method B			Performances						
			M6	M8	M10	M12	M12D	M16	M20
Any load direction									
TP DA+, TP DAL+									
F_{Rk}^0	Characteristic resistance in C12/15 concrete:	[kN]	1.5	3.0	4.0	6.0	--	9.0	16.0
F_{Rk}^0	Characteristic resistance in C20/25 to C50/60 concrete:	[kN]	2.0	3.0	5.0	7.5	6.0	12.0	20.0
γ_{ins}	Installation safety factor:	[-]	1.2	1.2	1.4	1.4	1.4	1.4	1.4
S_{cr}	Critical spacing:	[mm]	75	90	120	150	200	195	240
C_{cr}	Critical edge distance:	[mm]	40	45	60	75	150	100	120
TP DAS+									
F_{Rk}^0	Characteristic resistance in C20/25 to C50/60 concrete:	[kN]	--	2.5	4.0	4.0	--	--	--
γ_{ins}	Installation safety factor:	[-]	--	1.2	1.2	1.2	--	--	--
S_{cr}	Critical spacing:	[mm]	--	120	120	120	--	--	--
C_{cr}	Critical edge distance:	[mm]	--	60	60	60	--	--	--
Shear loads: steel failure with lever arm									
$M_{Rk,s}^0$	Characteristic bending moment, steel class 4.6	[Nm]	6.1	15.0	29.9	52.4	52.4	133.3	259.8
γ_{Ms}^1	Partial safety factor:	[-]	1.67						
$M_{Rk,s}^0$	Characteristic bending moment, steel class 4.8	[Nm]	6.1	15.0	29.9	52.4	52.4	133.3	259.8
γ_{Ms}^1	Partial safety factor:	[-]	1.25						
$M_{Rk,s}^0$	Characteristic bending moment, steel class 5.6	[Nm]	7.6	18.8	37.4	65.5	65.5	166.6	324.8
γ_{Ms}^1	Partial safety factor:	[-]	1.67						
$M_{Rk,s}^0$	Characteristic bending moment, steel class 5.8	[Nm]	7.6	18.8	37.4	65.5	65.5	166.6	324.8
γ_{Ms}^1	Partial safety factor:	[-]	1.25						
$M_{Rk,s}^0$	Characteristic bending moment, steel class 6.8	[Nm]	9.2	22.5	44.9	78.7	78.7	199.9	389.7
γ_{Ms}^1	Partial safety factor:	[-]	1.25						
$M_{Rk,s}^0$	Characteristic bending moment, steel class 8.8	[Nm]	12.2	30.0	59.9	104.9	104.9	266.6	519.7
γ_{Ms}^1	Partial safety factor:	[-]	1.25						

1) In absence of other national regulations

TP DA+, TP DAL+, TP DAS+ anchor	Annex C4
Performances	
Essential characteristics in concrete	

English translation prepared by IETcc

Table C4: Essential characteristics in concrete to loads of design method B according to EN 1992-4 for TP DA-A4+ anchor

Essential characteristic of resistance to loads of design method B			Performances					
			M6	M8	M10	M12	M16	M20
All load direction								
F_{Rk}^0	Characteristic resistance in C20/25 to C50/60 concrete:	[kN]	2.5	3.5	3.5	6.5	12.5	16.5
γ_{ins}	Installation safety factor:	[-]	1.4					
S_{cr}	Critical spacing:	[mm]	200	200	200	200	260	320
C_{cr}	Critical edge distance:	[mm]	150	150	150	150	195	240
Shear loads: steel failure with lever arm								
$M_{Rk,s}^0$	Characteristic bending moment, steel class A4-50	[Nm]	7.6	18.8	37.4	65.6	166.6	324.8
$\gamma_{Ms}^{1)}$	Partial safety factor:	[-]	2.38					
$M_{Rk,s}^0$	Characteristic bending moment, steel class A4-70	[Nm]	10.6	6.3	52.4	91.8	233.1	454.7
$\gamma_{Ms}^{1)}$	Partial safety factor:	[-]	1.56					
$M_{Rk,s}^0$	Characteristic bending moment, steel class A4-80	[Nm]	12.2	30.0	59.9	104.9	266.6	519.7
$\gamma_{Ms}^{1)}$	Partial safety factor:	[-]	1.34					

1) In absence of other national regulations

TP DA-A4+ anchor	Annex C5
Performances	
Essential characteristic in concrete	

English translation prepared by IETcc

Table C5: Essential characteristic in precast prestressed hollow core slabs to loads of design method B according to EN 1992-4 for TP DAS+ anchor

Essential characteristics of resistance to loads of design method B			Performances						
			M6	M8	M10	M12	M12D	M16	M20
Any load direction									
TP DAS+									
F_{Rk}^0	Characteristic resistance in prestressed hollow core concrete slabs C30/37 to C50/60:	[kN]	--	5,5	6,0	6,5	--	--	--
γ_{ins}	Installation safety factor:	[-]	--	1.2	1.4	1.4	--	--	--
S_{cr}	Critical spacing:	[mm]	--	200	200	200	--	--	--
C_{cr}	Critical edge distance:	[mm]	--	150	150	150	--	--	--
Shear loads: steel failure with lever arm									
$M_{Rk,s}^0$	Characteristic bending moment, steel class 4.6	[Nm]	--	15.0	29.9	52.4	--	--	--
$\gamma_{Ms}^{1)}$	Partial safety factor:	[-]	--	1.67			--	--	--
$M_{Rk,s}^0$	Characteristic bending moment, steel class 4.8	[Nm]	--	15.0	29.9	52.4	--	--	--
$\gamma_{Ms}^{1)}$	Partial safety factor:	[-]	--	1.25			--	--	--
$M_{Rk,s}^0$	Characteristic bending moment, steel class 5.6	[Nm]	--	18.8	37.4	65.5	--	--	--
$\gamma_{Ms}^{1)}$	Partial safety factor:	[-]	--	1.67			--	--	--
$M_{Rk,s}^0$	Characteristic bending moment, steel class 5.8	[Nm]	--	18.8	37.4	65.5	--	--	--
$\gamma_{Ms}^{1)}$	Partial safety factor:	[-]	--	1.25			--	--	--
$M_{Rk,s}^0$	Characteristic bending moment, steel class 6.8	[Nm]	--	22.5	44.9	78.7	--	--	--
$\gamma_{Ms}^{1)}$	Partial safety factor:	[-]	--	1.25			--	--	--
$M_{Rk,s}^0$	Characteristic bending moment, steel class 8.8	[Nm]	--	30.0	59.9	104.9	--	--	--
$\gamma_{Ms}^{1)}$	Partial safety factor:	[-]	--	1.25			--	--	--

1) In absence of other national regulations

TP DAS+ anchor

Performances

Essential characteristics in precast prestressed hollow core concrete slabs

Annex C6

English translation prepared by IETcc

Table C6: Essential characteristics under fire exposure in concrete C20/25 to C50/50 in any load direction according to EN 1992-4 for TP DA+, TP DAL+ anchor

Essential characteristics under fire exposure in concrete C20/25 to C50/60 in any load direction		Performances						
		M6	M8	M10	M12	M12D	M16	M20
R30	Characteristic resistance: $F_{Rk,fi30}^{0\ 1)}$ [kN]	0.2	0.4	0.9	1.7	1.7	3.1	4.9
R60	Characteristic resistance: $F_{Rk,fi60}^{0\ 1)}$ [kN]	0.2	0.3	0.8	1.3	1.3	2.4	3.7
R90	Characteristic resistance: $F_{Rk,fi90}^{0\ 1)}$ [kN]	0.1	0.3	0.6	1.1	1.1	2.0	3.2
R120	Characteristic resistance: $F_{Rk,fi120}^{0\ 1)}$ [kN]	0.1	0.2	0.5	0.8	0.8	1.6	2.5
R30 to R120	Spacing $S_{cr,fi}$ [mm]	4 x hef						
R120	Edge distance $C_{cr,fi}$ [mm]	2 x hef						

¹⁾ in absence of other national regulations the partial safety factor for resistance under fire exposure $\gamma_{M,fi} = 1.0$ is recommended
If fire attack is from more than one side, the design method may be taken if edge distance of the anchor is $c \geq 300$ mm

Table C7: Essential characteristics under fire exposure in concrete C20/25 to C50/50 in any load direction according to EN 1992-4 for TP DAS+ anchor

Essential characteristics under fire exposure in concrete C20/25 to C50/60 in any load direction		Performances					
		M6	M8	M10	M12	M16	M20
R30	Characteristic resistance: $F_{Rk,fi30}^{0\ 1)}$ [kN]	--	0.54	0.54	0.54	--	--
R60	Characteristic resistance: $F_{Rk,fi60}^{0\ 1)}$ [kN]	--	0.54	0.54	0.54	--	--
R90	Characteristic resistance: $F_{Rk,fi90}^{0\ 1)}$ [kN]	--	0.44	0.54	0.54	--	--
R120	Characteristic resistance: $F_{Rk,fi120}^{0\ 1)}$ [kN]	--	0.37	0.43	0.43	--	--
R30 to R120	Spacing $S_{cr,fi}$ [mm]	--	4 x hef			--	--
R120	Edge distance $C_{cr,fi}$ [mm]	--	2 x hef			--	--

¹⁾ in absence of other national regulations the partial safety factor for resistance under fire exposure $\gamma_{M,fi} = 1.0$ is recommended
If fire attack is from more than one side, the design method may be taken if edge distance of the anchor is $c \geq 300$ mm

Table C8: Essential characteristics under fire exposure in concrete C20/25 to C50/50 in any load direction according to EN 1992-4 for TP DA-A4+ anchor

Essential characteristics under fire exposure in concrete C20/25 to C50/60 in any load direction		Performances					
		M6	M8	M10	M12	M16	M20
R30	Characteristic resistance: $F_{Rk,fi30}^{0\ 1)}$ [kN]	0.20	0.73	0.87	1.63	3.19	4.12
R60	Characteristic resistance: $F_{Rk,fi60}^{0\ 1)}$ [kN]	0.18	0.59	0.87	1.63	3.19	4.12
R90	Characteristic resistance: $F_{Rk,fi90}^{0\ 1)}$ [kN]	0.14	0.44	0.87	1.63	3.14	4.12
R120	Characteristic resistance: $F_{Rk,fi120}^{0\ 1)}$ [kN]	0.10	0.37	0.69	1.30	2.51	3.30
R30 to R120	Spacing $S_{cr,fi}$ [mm]	4 x hef					
R120	Edge distance $C_{cr,fi}$ [mm]	2 x hef					

¹⁾ in absence of other national regulations the partial safety factor for resistance under fire exposure $\gamma_{M,fi} = 1.0$ is recommended
If fire attack is from more than one side, the design method may be taken if edge distance of the anchor is $c \geq 300$ mm

TP DA+, TP DAL+, TP DAS+, TP DA-A4+ anchor

Performances

Essential characteristics under fire exposure

Annex C7