

**INSTITUTO DE CIENCIAS  
DE LA CONSTRUCCIÓN  
EDUARDO TORROJA**

C/ Serrano Galvache 4. 28033 Madrid (Spain)  
Tel.: (34) 91 302 04 40.  
[direccion.ietcc@csic.es](mailto:direccion.ietcc@csic.es) <https://dit.iecc.csic.es>

## European Technical Assessment

## ETA 21 / 1110 of 27/02/2022

English translation prepared by IETcc. Original version in Spanish language

### General part

**Technical Assessment Body issuing the ETA designated according to Art. 29 of Regulation (EU) 305/2011:**

Instituto de Ciencias de la Construcción Eduardo Torroja (IETcc)

**Trade name of the construction product:**

**BUILDBOND PE, BUILBOND FR**

**Product family to which the construction product belongs:**

Thin metal composite sheet

**Manufacturer:**

**ALUBUILD L.d.a.**  
Parque Industrial de Gême,  
4730-180 Vila Verde – Portugal

**Manufacturing plant:**

**ALUBUILD L.d.a.**  
Parque Industrial de Gême,  
4730-180 Vila Verde – Portugal

**This European Technical Assessment contains:**

8 pages including 2 annexes which form an integral part of the assessment. Annex 2 contains confidential information and is not included in the European Technical Assessment when that assessment is publicly available.

**This European Technical Assessment is issued in accordance with regulation (EU) No 305/2011, on the basis of:**

EAD 210046-00-1201 ed. February 2018.  
Thin Metal Composite Sheet

**This ETA is a corrigendum of:**

ETA 21/1110 version 1 issued on the 17/02/2022

Translations of this European Technical Assessment in other languages shall fully correspond to the original issued document and shall be identified as such.

This European Technical Assessment may be withdrawn by the issuing Technical Assessment Body, in particular pursuant to information by the Commission according to Article 25 Paragraph 3 of Regulation (EU) No 305/2011.

## Specific part

### 1. Technical description of the product

The subject of this European Technical Assessment (ETA) are thin metal composite sheets (TCMS). TCMS consists of two thin layers of metallic skin, which are sandwiching a core in a continuous co-extrusion process. External face of metallic skin can be pre-coated or not. The joining of metallic skins with core is achieved by adhesive which is applied to the core and which is then faced with the top and bottom coated metallic sheets. The bond is formed by temperature and pressure under controlled conditions. The product is subsequently cut to range of sheet sizes. The TMCS Buildbond PE and Buildbond FR are 4 mm thin metal composite sheets composed by:

- Faced skins made of aluminium alloy sheets AW 5005/3005/3105 according to EN 485-2<sup>1</sup> with an 0,50 mm nominal thickness and a tolerance quote according EN 485-4<sup>2</sup>. The sheets are coated on the top surface with a polyvinylidene fluoride (PVDF) or High-density polyester (HDPE) and a polyester (PE) based primer below according to EN 1396<sup>3</sup>. The reverse side is coated with a polyester (PE) based primer.
- An inner low density polyethylene solid core (LDPE) of thermoplastic resins or an inner polymer and fire retardant mineral solid core (FR).
- Adhesive layer for bonding faced skins and core through a continuous industrial process
- 

Further information is presented at Tables 1 and 2:

**Table 1.1: Physical data of components of thin metal composite sheet Buildbond PE**

TMCS	Material		Characteristics	Value
Buildbond PE 4±0,2 mm	Removable protection film		Aspect: Thickness (µm):	White and grey 100
	Coating of alloyed aluminium external sheet	HDPE	Thickness primer (mm): Thickness lacquered layer (mm):	≥ 10 ≥ 20
		PVDF 70/30	Thickness bi-layer (µm): Thickness three-layer(µm):	25±4 40±6
	External sheet of coated alloyed aluminium EN AW 5005/3005/3105	H42 H44 H46	Thickness (mm): Linear thermal expansion coefficient (K <sup>-1</sup> ):	0,5±0,05 23 x 10 <sup>-6</sup>
	Adhesive		Thickness (mm):	0,05
			Colour:	Transparent
	Full mineral core	LDPE	Aspect:	White
			Thickness (mm):	3
			Composition:	Confidential (Annex B)
			Density (kg/m <sup>3</sup> ):	900-960
	Adhesive		Thickness (mm):	0,05
			Colour:	Transparent
Rear sheet of coated alloyed aluminium EN AW 5005/3105/3005	H42 H44 H46	Thickness (mm): Linear thermal expansion coefficient (K <sup>-1</sup> ):	0,50±0,05 23 x 10 <sup>-6</sup>	
Coating of alloyed aluminium inner sheet	PE coating	Thickness (µm):	5±2 10±2	

**Table 1.2: Mechanical data of components of thin metal composite sheet Buildbond PE**

TMCS	Material	Characteristic	Value	
Buildbond PE 4±0,2 mm	External sheet of coated alloyed aluminium EN AW 5005/3005/3105 H42 or H44 or H46	E Modulus (MPa)	70 000	
		Tensile strength R <sub>m</sub> (MPa) <sup>(3)</sup>	H42	125-165
			H44	145-185
			H46	165-205
		Yield strength R <sub>p</sub> 0,2 (MPa) <sup>(3)</sup>	H42	>80
			H44	>110
H46	>135			

<sup>(1)</sup> EN 485-2:2016. Aluminium and aluminium alloys. Sheet, strip and plate. Part.2. Mechanical properties

<sup>(2)</sup> EN 485-4:1993. Aluminium and aluminium alloys - Sheet, strip and plate - Part 4: Tolerances on shape and dimensions for cold-rolled products.

<sup>(3)</sup> EN 1396:2015. Aluminium and aluminium alloys - Coil coated sheet and strip for general applications - Specifications

		Elongation A <sub>50</sub> (%) <sup>(3)</sup>	H42	>4	
			H44	>3	
			H46	>2	
	Rear sheet of alloyed aluminium EN AW 5005/3005/3105 H42 or H44 or H46	E Modulus (MPa)		70 000	
		Tensile strength R <sub>m</sub> (MPa) <sup>(3)</sup>		145-185	
Yield strength R <sub>p</sub> 0,2 (MPa) <sup>(3)</sup>		>110			
		Elongation A <sub>50</sub> (%) <sup>(3)</sup>	>3		

**Table 2.1: Physical declared data of components Buildbond FR**

TMCS	Material		Characteristics	Value
Buildbond FR 4±0,2 mm	Removable protection film		Aspect: Thickness (µm):	White and grey 100
	Coating of alloyed aluminium external sheet	HDPE	Thickness primer (mm): Thickness lacquered layer (mm):	≥ 10 ≥ 20
		PVDF 70/30	Thickness bi-layer (µm): Thickness three-layer(µm):	25±4 40±6
	External sheet of coated alloyed aluminium 5005/3005/3105	H42 H44 H46	Thickness (mm): Linear thermal expansion coefficient (K <sup>-1</sup> ):	0,5±0,05 23 x 10 <sup>-6</sup>
	Adhesive		Thickness (mm): Colour:	0,05 Transparent
	Full mineral core	FR	Aspect:	Black
			Thickness (mm):	3
			Composition:	Confidential (Annex B)
			Density (kg/m <sup>3</sup> ):	1.400-1.600
	Adhesive		Thickness (mm): Colour:	0,05 Transparent
	Rear sheet of coated alloyed aluminium 5005/3105/3005	H42 H44 H46	Thickness (mm): Linear thermal expansion coefficient (K <sup>-1</sup> ):	0,5±0,05 23 x 10 <sup>-6</sup>
	Coating of alloyed aluminium inner sheet	PE coating	Thickness (µm):	5±2 10±2

**Table 2.2: Mechanical declared data of thin metal composite sheet Buildbond FR**

TMCS	Material		Characteristic	Value
Buildbond FR 4±0,2 mm	External sheet of coated alloyed aluminium EN AW 5005/3005/3105 H42 or H44 or H46	E Modulus (MPa)		70 000
		Tensile strength R <sub>m</sub> (MPa) <sup>(3)</sup>	H42	125-165
			H44	145-185
			H46	165-205
		Yield strength R <sub>p</sub> 0,2 (MPa) <sup>(3)</sup>	H42	>80
			H44	>110
			H46	>135
	Elongation A <sub>50</sub> (%) <sup>(3)</sup>	H42	>4	
		H44	>3	
		H46	>2	
Rear sheet of alloyed aluminium EN AW 5005/3005/3105 H42 or H44 or H46	E Modulus (MPa)		70 000	
	Tensile strength R <sub>m</sub> (MPa) <sup>(3)</sup>		145-185	
	Yield strength R <sub>p</sub> 0,2 (MPa) <sup>(3)</sup>		>110	
	Elongation A <sub>50</sub> (%) <sup>(3)</sup>		>3	

## **2. Specification of the intended use in accordance with the applicable EAD.**

### **2.1 Intended use**

The (TCMS) product is intended to be used for manufacturing of:

- Cladding elements (cassettes/coffering, panels) in external and internal wall cladding kits
- Parts (filling elements) of partition kits.
- Filling elements in external or internal supported ceilings.
- Rail filling.
- Substrate boards for information and orientation systems.

The provisions made in this European Technical Assessment are based on an assumed working life of 25 years as minimum according to EAD, provided that the TMCSs are subject to appropriate use and maintenance.

The indications given on the working life cannot be interpreted as a guarantee given by the producer, but are to be regarded only as a means for choosing the right product in relation to the expected economically reasonable working life of the works.

### **2.2. Manufacturing**

The European Technical Assessment is issued for the TMCSs on the basis of agreed data/information, deposited with the Instituto de Ciencias de la Construcción Eduardo Torroja (IETcc), which identifies the product that has been assessed and judged. Changes to the product or production process, which could result in this deposited data/information being incorrect, shall be notified to IETcc before changes are introduced.

IETcc will decide whether or not such changes affect the ETA and consequently the validity of the CE marking on the basis of the ETA and if so whether further assessment or alterations to the ETA shall be necessary.

### **2.3. Design and installation**

It is assumed that the product will be installed according to the manufacturer's instructions or (in the absence of such instructions) according to the usual practice of the building professionals.

### **2.4. Packaging, transport and storage**

The information on packaging, transport, and storage is given in the manufacturer's technical documentation. It is the responsibility of the manufacturer(s) to ensure that this information is made known to the concerned people. Products must be stored in a dry and cool place and protected from sun, rain and snow.

### **2.5. Use, maintenance and repair**

Maintenance of the installation of the construction elements resulting from manufacturing of TMCS should include inspections on site, taking into account the following aspects:

- Appearance of any damage such as cracking, delamination or detachment due to permanent and irreversible deformation.

- Regarding other metallic elements used for its fixing: Presence of corrosion or water accumulation.
- Necessary repairs should be done rapidly, using the same TMCS components and following the repair instructions given by ETA holder.

The information on use, maintenance and repair is given in the manufacturer's technical documentation. It is the responsibility of the manufacturer to ensure that this information is made known to the concerned people.

### 3. Performance of the product and references to the methods used for its assessment

- **Basic Works Requirement 2. Safety in case of fire:**

#### 3.1.1 Reaction to fire

**Table 3. Classification of TMCS according to EAD 210046-00-1201 Cl. 2.2.1**

Thin metal composite sheet	Thickness: Nominal / skin / skin Material	Performance	Class
Buildbond PE	4 / 0,5 / 0,5 Alloyed aluminium	Reaction to fire	No performance assessed
Buildbond FR (HDPE)	4 / 0,5 / 0,5 Alloyed aluminium	Reaction to fire	No performance assessed
Buildbond FR (PVDF)	4 / 0,5 / 0,5 Alloyed aluminium	Reaction to fire	B-s1,d0

Based on Tests Report (ref. Nr. 4367T21-Part 1) and Classification Report (ref. Nr. 4367T21-Part 2) (issued by AFITI LICOF – Center for Fire Testing and Research). The product was tested according to Annex E of EAD 21004600-1201, using TMCS with PVDF based primer, open horizontal and vertical joints of 20 mm, fixed to an aluminium substructure of vertical aluminium profiles fixed to the substrate, considering an air gap cavity of at least 40 mm between the TMCS and an insulation layer made of mineral wool 50 mm thickness and 70 kg/m<sup>3</sup> density. A 10 mm joint was left between the panel and the top of the U-Profile of the test frame to ensure ventilation in the air gap.

The tests were carried out according to the European Standards EN ISO 1716<sup>(4)</sup> and EN 13823<sup>(5)</sup>, and the corresponding classification according to the European Standard EN 13501-1<sup>(6)</sup> and Commission Delegated Regulation N. 2016/364.

- **Basic Works Requirement 4. Safety and accessibility in use:**

3.2.1 Tensile performance core included: No performance assessed

3.2.2 Tensile performance without core: No performance assessed

3.2.3 Tensile strength perpendicular to the face: No performance assessed

3.2.4. Flexural performance:

The initial bending strength  $R_{bend,INI}$  has been determined according to EAD 210046-00-1201, clause 2.2.4.

(4) EN ISO 11925-2:2021. Reaction to fire tests for products – Ignitability of products subjected to direct impingement of flame. Part 2: Single flame source test

(5) EN 13823:2021. Reaction to fire tests for building products - Building products excluding floorings exposed to the thermal attack by a single burning item.

(6) EN 13501-1:2019. Fire classification of construction products and building elements-Part 1: Classification using data from reaction to fire tests.

**Table 4. Bending strength in four-point test arrangement (length span 300 mm) of TMCS**

Thickness: Nominal / skin / skin material	Performance		Average value	Standard deviation ( $\sigma_n$ )	Characteristic value ( $R_{bend,k}$ )	One-sided bottom confidence level at the confidence level 95 %
Buildbond PE 4 / 0,5 / 0,5 Alloyed aluminium	Bending strength $R_{bend,INI}$	[MPa]	92,33	1,25	90,31	--
	Bending modulus of elasticity $E_{bend}$	[GPa]	25,75	0,36	--	25,53 - 25,68
Buildbond FR 4 / 0,5 / 0,5 Alloyed aluminium	Bending strength $R_{bend,INI}$	[MPa]	115,92	0,64	114,53	--
	Bending modulus of elasticity $E_{bend}$	[GPa]	28,88	0,12	--	28,77 - 28,94

**Table 5. Bending strength in three-point test arrangement (length span 250 mm) of TMCS**

Thickness: Nominal / skin / skin material	Performance		Average value	Standard deviation ( $\sigma_n$ )	Characteristic value ( $R_{flex,k}$ )	Remarks
Buildbond PE 4 / 0,5 / 0,5 Alloyed aluminium	Bending strength $R_{flex,INI}$	[MPa]	91,88	1,42	88,88	No breakage
Buildbond FR 4 / 0,5 / 0,5 Alloyed aluminium	Bending strength $R_{flex,INI}$	[MPa]	117,85	1,66	114,20	No breakage

3.2.5. Shear performance: No performance assessed

3.2.6. Thickness:

3.2.6.1. Total thickness of sheet

**Table 6. Thickness of sheet**

TMCS	Thickness in average [mm]	Two-sided confidence interval of thickness $d_{0,975}$ [mm]
Buildbond PE	3,999	3,977- 4,022
Buildbond FR	4,067	4,062 – 4,073

3.2.6.2. Thickness of skin: No performance assessed

3.2.7. Apparent and density: No performance assessed

3.2.8. Torque Peeling strength: No performance assessed

**Table 7. Peeling strength ASTM D 1781-98**

TMCS	Values	Performance			Std. Dev [N.m/m]	Two-sided confidence interval of torque peel strength in initial state $T_{INI,0,975}$ [N.m/m]
		Force $F_0$	T ini	Torque peeling T ini [N.m/m] average		
Buildbond PE 4 / 0,5 / 0,5 Alloyed aluminium	Rear side	845,20	357,10	382,48	19,42	334,23 – 430,73
		937,70	404,28			
		901,97	386,05			
	Front side	764,97	316,18	331,33	12,81	299,51 – 363,15
		826,40	347,51			
		792,63	330,29			
Buildbond FR 4 / 0,5 / 0,5 Alloyed aluminium	Rear side	689,30	275,52	308,85	35,26	221,27 - 396,43
		850,30	357,63			
		724,33	293,39			
	Front side	816,97	340,05	345,89	37,87	251,82 – 439,96
		924,57	394,92			
		743,77	302,71			

3.2.9. Hard body impact: No performance assessed

- **Basic Works Requirement 5. Protection against noise:**

3.2.10. Dynamic stiffness: No performance assessed

- **Basic Works Requirement 6. Energy economy and heat retention:**

3.2.11. Coefficient of thermal conductivity: No performance assessed

- **Basic Works Requirement 7. Sustainable use of natural resources:**

3.2.12. Durability: No performance assessed

#### **4. Assessment and verification of constancy of performance AVCP**

With regard to reaction to fire for products covered by this EAD the applicable European legal act is Decision 2003/64/EC. The systems are:

- For thin metal composite sheet BUILDBOND FR: System 1
- For thin metal composite sheet BUILDBOND PE: System 2+

#### **5. Technical details necessary for the implementation of the AVCP system, as provided for in the applicable EAD**

The ETA is issued for this kit on the basis of agreed data/information which identifies the product that has been assessed and judged. Detailed description and conditions of the manufacturing process of the kit, and all the relevant design and installation criteria of this kit are specified in the manufacturer's technical documentation deposited with the IETcc. The main aspects of this information are specified in the following sections. It is the manufacturer's responsibility to make sure that all those who use the kit are appropriately informed of specific conditions according to sections 1, 2, 3, 4 and 5 including the annexes of this ETA.



Instituto de Ciencias de la Construcción Eduardo Torroja  
**CONSEJO SUPERIOR DE INVESTIGACIONES CIENTÍFICAS**

c/ Serrano Galvache n. 4. 28033 Madrid.  
Tel.: (34) 91 302 04 40  
<https://dit.ietcc.csic.es>



On behalf of the Instituto de Ciencias de la Construcción Eduardo Torroja  
Madrid, 27<sup>th</sup> February 2022

Director



## Annex 1: Figure

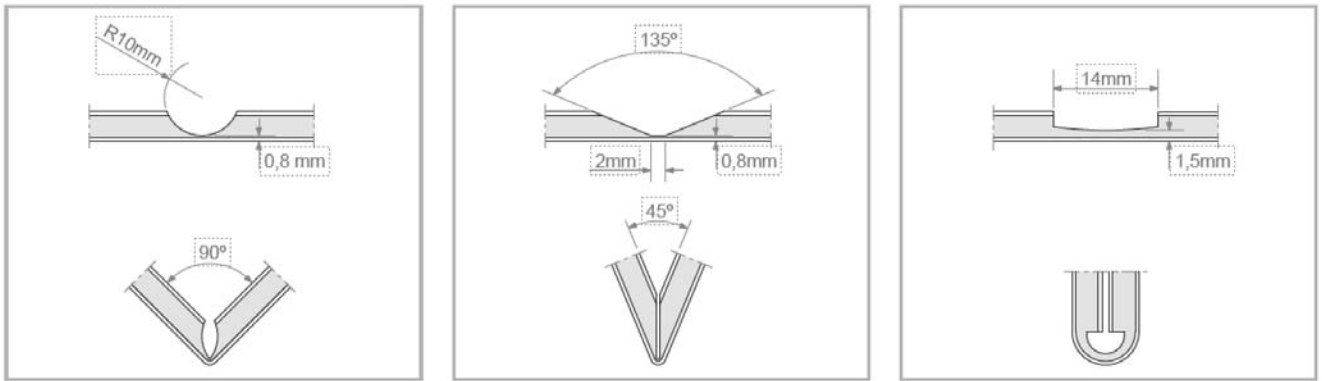

## Annex 2: Quality control of components of kits manufactured by suppliers or holder

This confidential information and is not included in the European Technical Assessment when that assessment is publicly available.