



**INSTITUTO DE CIENCIAS
DE LA CONSTRUCCIÓN
EDUARDO TORROJA**

C/ Serrano Galvache n. 4 28033 Madrid (Spain)
Tel.: (34) 91 302 04 40 Fax: (34) 91 302 07 00
direccion.ietcc@csic.es <https://dit.ietcc.csic.es>

European Technical Assessment

ETA 21/0893 of 25/10/2021

English translation prepared by IETcc. Original version in Spanish language

General Part

Technical Assessment Body issuing the ETA designated according to Art. 29 of Regulation (EU) 305/2011:

Instituto de Ciencias de la Construcción Eduardo Torroja (IETcc)

Trade name of the construction product:

Mechanical anchor W-HR / W-HR A2

Product family to which the construction product belongs:

Torque controlled expansion anchor made of galvanised steel and stainless steel of diameters 8, 10, 12, 16 and 20 for use in non-cracked concrete.

Manufacturer:

Würth España S.A.

C/ Joiers 21
08184 Palau-solità i Plegamans, Barcelona.
España
Página web: www.wurth.es

Manufacturing plant:

Würth plant 2
Würth plant 3

This European Technical Assessment contains:

12 pages including 3 annexes which form an integral part of this assessment.

This European Technical Assessment is issued in accordance with regulation (EU) No 305/2011, on the basis of:

European Assessment Document EAD 330232-00-0601 "Mechanical Fasteners for use in concrete", ed. October 2016

English translation prepared by IETcc

This European Technical Assessment is issued by the Technical Assessment Body in its official language. Translations of this European Technical Assessment in other languages shall fully correspond to the original issued document and should be identified as such.

This European Technical Assessment may be withdrawn by the issuing Technical Assessment Body, in particular pursuant to information by the Commission according to article 25 (3) of Regulation (EU) No 305/2011.

SPECIFIC PART

1. Technical description of the product

The Würth W-HR sleeve anchor in the range of diameters 8, 10, 12, 16 and 20 is an anchor made of galvanised steel. The Würth W-HR A2 sleeve anchor in the range of diameters 8, 10, 12, 16 and 20 is an anchor made of stainless steel. The anchor is installed into a predrilled cylindrical hole and anchored by torque-controlled expansion. The anchorage is characterised by friction between the expansion sleeve and the concrete.

Product and installation descriptions are given in annexes A1 and A2.

2. Specification of the intended use in accordance with the applicable European Assessment Document.

The performances given in section 3 are only valid if the anchor is used in compliance with the specifications and conditions given in annex B.

The verifications and assessment methods on which this European Technical Assessment is based lead to the assumption of a working life of the anchor of at least 50 years. The indications given on the working life cannot be interpreted as a guarantee given by the producer, but are to be regarded only as a means to choosing the right products in relation to the expected economically reasonable working life of the works.

3. Performance of the product and references to the methods used for its assessment

3.1 Mechanical resistance and stability (BWR 1)

Essential characteristic	Performance
Product performance for static or quasi static actions	See annex C

3.2 Safety in case of fire (BWR 2)

Essential characteristic	Performance
Reaction to fire	Anchorage satisfies requirements for class A1 according to EN 13501-7
Resistance to fire	No performance assessed

4. Assessment and verification of constancy of performance (hereinafter AVCP) system applied, with reference to its legal base

The applicable European legal act for the system of Assessment and Verification of Constancy of Performances (see annex V to Regulation (EU) No 305/2011) is 96/582/EC.

The system to be applied is 1.

English translation prepared by IETcc

5. Technical details necessary for the implementation of the AVCP system, as provided for in the applicable European Assessment Document.

The technical details necessary for the implementation of the AVCP system are laid down in the quality plan deposited at Instituto de Ciencias de la Construcción Eduardo Torroja.



Instituto de Ciencias de la Construcción Eduardo Torroja
CONSEJO SUPERIOR DE INVESTIGACIONES CIENTÍFICAS

C/ Serrano Galvache n.º 4. 28033 Madrid.
Tel: (+34) 91 302 04 40 Fax. (+34) 91 302 07 00
<https://dit.ietcc.csic.es>



On behalf of the Instituto de Ciencias de la Construcción Eduardo Torroja
Madrid, 25th of October 2021



Director IETcc - CSIC

English translation prepared by IETcc

Product and identification

W-HR sleeve anchor

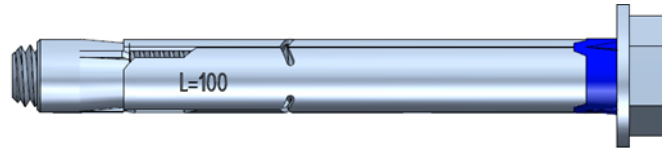

Hexagonal head
classes 6.8 or 8.8;
A2-70

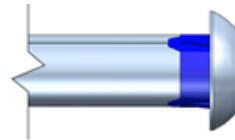

Round head, class
5.6

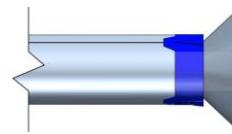

Countersunk head,
class 10.9; A2-70

Identification on anchor:

- Expansion sleeve: Company logo / metric x diameter / length
- Hexagonal bolt: Bolt class (6.8, 8.8, A2-70)
- Countersunk bolt: Bolt class (10.9, A2-70)

Installed condition

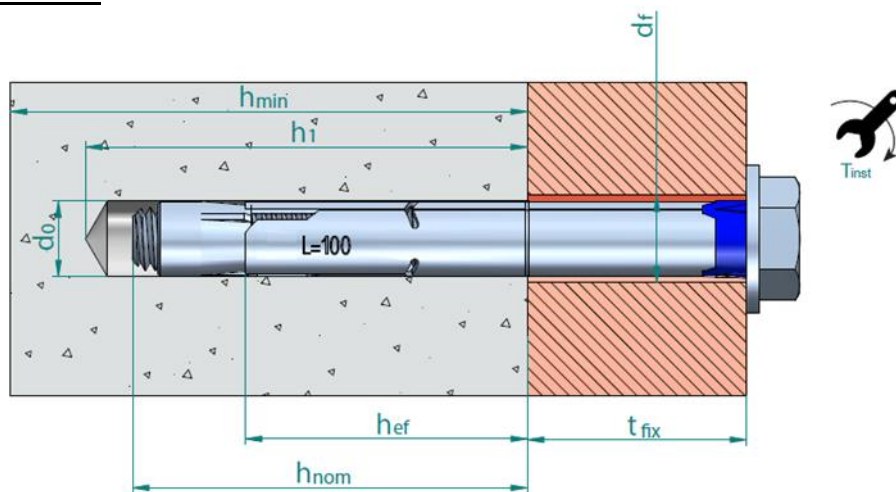

- d_0 : Nominal diameter of drill bit
- d_f : Fixture clearance hole diameter
- h_{ef} : Effective anchorage depth
- h_1 : Depth of drilled hole
- h_{nom} : Overall anchor embedment depth in the concrete
- h_{min} : Minimum thickness of concrete member
- t_{fix} : Fixture thickness
- T_{ins} : Installation torque

W-HR, W-HR A2 sleeve anchor

Product description and installed condition

Identification

Annex A1

English translation prepared by IETcc

Table A1: W-HR materials

Item	Component	Rounded version, class 5.6	Hexagonal version, class 6.8	Hexagonal version, class 8.8	Countersunk version, class 10.9
1	Bolt	Round head bolt, class 5.6 ISO 898-1, galvanised $\geq 5 \mu\text{m}$ ISO 4042 A2	DIN 931 bolt, class 6.8 ISO 898-1, galvanised $\geq 5 \mu\text{m}$ ISO 4042 A2	DIN 931 bolt, class 8.8 ISO 898-1, galvanised $\geq 5 \mu\text{m}$ ISO 4042 A2	DIN 7991, class 10.9 ISO 898-1, galvanised $\geq 5 \mu\text{m}$ ISO 4042 A2
2	Washer	Carbon steel, galvanised $\geq 5 \mu\text{m}$ ISO 4042 A2			
3	Collar	POM plastic element			
4	Sleeve	Carbon steel, galvanised $\geq 5 \mu\text{m}$ ISO 4042 A2			
5	Cone	Carbon steel, galvanised $\geq 5 \mu\text{m}$ ISO 4042 A2			

Table A2: W-HR A2 materials

Item	Component	Hexagonal version, class A2-70	Countersunk version, class A4-70
1	Bolt	DIN 931 bolt, class A2-70 ISO 3506-1	DIN 7991, class A2-70 ISO 3506-1
2	Washer	Stainless steel, grade A2	
3	Collar	POM plastic element	
4	Sleeve	Stainless steel, grade A2	
5	Cone	Stainless steel, grade A2	

W-HR, W-HR A2 sleeve anchor	Annex A2
Product description	
Materials	

English translation prepared by IETcc

Intended use

Anchorage subjected to:

- Static or quasi static loads, all sizes and embedment depths

Base materials:

- Reinforced and unreinforced concrete according to EN 206:2013
- Strength classes C20/25 to C50/60 according to EN 206:2013
- Uncracked concrete

Use conditions (environmental conditions):

- W-HR: structures subjected to dry internal conditions.
- W-HR A2: structures subjected to dry internal conditions or to atmospheres under Corrosion Resistance Class CRC II according to EN 1993-1-4:2006+A1-2015 annex A.

Design:

- Anchorages are designed under the responsibility of an engineer experienced in anchorages and concrete.
- Verifiable calculation rules and drawings are prepared taking into account of the loads to be attached. The position of the anchor is indicated on the design drawings (e.g. position of the anchor relative to reinforcement or to supports, etc.)
- Anchorages under static or quasi-static are designed for design Method A in accordance with EN 1992-4:2018
- Diameter 8 / M6 sleeve anchor: use restricted to anchoring of structural components which are statically indeterminate, when in case of failure, the load can be distributed to other fasteners.

Installation:

- Hammer drilling only.
- Anchor installation carried out by appropriately qualified personal and under the supervision of the person responsible for technical matters of the site.
- In case of aborted hole: new drilling at a minimum distance away of twice the depth of aborted hole or smaller distance if the aborted hole is filled with high strength mortar and if under shear or oblique tension load it is not the direction of the load application.

W-HR, W-HR A2 sleeve anchor	Annex B1
Intended use	
Specifications	

Table C1: Installation parameters

Installation parameters			Performances				
			Ø8 M6	Ø10 M8	Ø12 M10	Ø16 M12	Ø20 M16
d_0	Nominal diameter of drill bit:	[mm]	8	10	12	16	20
d_f	Fixture clearance hole diameter \leq	[mm]	9	12	14	18	22
T_{inst}	Nominal installation torque:	[Nm]	10	20	35	50	140
L	Total anchor length:	[mm]	45 60	60 80	70 100	80 110	110
h_{min}	Minimum thickness of concrete member:	[mm]	100	100	100	110	145
h_1	Depth of drilled hole \geq	[mm]	45	60	75	80	105
h_{nom}	Overall anchor embedment depth in concrete \geq	[mm]	39	51	65	70	92
h_{ef}	Effective anchorage depth:	[mm]	30	40	48	55	72
t_{fix}	Thickness of fixture \leq	[mm]	5 20	5 27	5 32	5 37	15
Socket	Hex head:	[-]	10	13	17	19	24
	Countersunk head:	[-]	#4	#5	#6	--	--
	Round head:	[-]	TX 40	TX 40	--	--	--
s_{min}	Minimum allowable spacing:	[mm]	41	54	65	74	97
c_{min}	Minimum allowable edge distance:	[mm]	41	54	65	74	97

Installation process

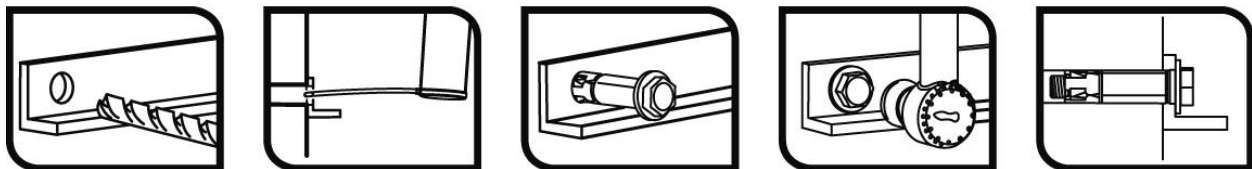

W-HR, W-HR A2 sleeve anchor

Performances

Installation parameters and installation procedure

Annex C1

Table C2: W-HR characteristic resistance values to tension loads of design method A according to EN 1992-4

W-HR: characteristic resistances under tension loads			Performances				
			Ø8 M6	Ø10 M8	Ø12 M10	Ø16 M12	Ø20 M16
STEEL FAILURE							
$N_{Rk,s}$	Characteristic resistance class 5.6:	[kN]	10.05	18.30	29.00	42.15	78.50
$\gamma_{M,s}$	Partial safety factor class 5.6:	[-]	2.00				
$N_{Rk,s}$	Characteristic resistance class 6.8:	[kN]	12.06	21.96	34.80	50.58	94.20
$\gamma_{M,s}$	Partial safety factor class 6.8:	[-]	1.50				
$N_{Rk,s}$	Characteristic resistance class 8.8:	[kN]	16.08	29.28	46.40	67.44	125.60
$\gamma_{M,s}$	Partial safety factor class 8.8:	[-]	1.50				
$N_{Rk,s}$	Characteristic resistance class 10.9:	[kN]	20.10	36.60	58.00	84.30	157.00
$\gamma_{M,s}$	Partial safety factor class 10.9:	[-]	1.50				
PULL OUT FAILURE							
$N_{Rk,p}$	Characteristic resistance in C20/25 uncracked concrete:	[kN]	5.5	10.0	--- ¹⁾	--- ¹⁾	--- ¹⁾
γ_{ins}	Installation safety factor:	[-]	1.0	1.0	1.2	1.2	1.0
Ψ_c	Increasing factors for $N^0_{Rk,c}$:	C30/37	1.22				
		C40/50	1.41				
		C50/60	1.55				
CONCRETE CONE FAILURE AND SPLITTING FAILURE							
h_{ef}	Effective anchorage depth:	[mm]	30	40	48	55	72
$k_{ucr,N}$	Factor for uncracked concrete:	[-]	11,0				
γ_{ins}	Installation safety factor:	[-]	1.0	1.0	1.2	1.2	1.2
$s_{cr,N}$	Concrete cone Spacing:	[mm]	3 x h_{ef}				
$s_{cr,N}$	failure: Edge distance:	[mm]	1.5 x h_{ef}				
$s_{cr,sp}$	Splitting Spacing:	[mm]	150	200	240	275	360
$s_{cr,sp}$	failure: Edge distance:	[mm]	75	100	120	138	180

¹⁾ Pull out not decisive

Table C3: W-HR displacements under tension loads

W-HR: displacements under tension loads			Performances				
			Ø8 M6	Ø10 M8	Ø12 M10	Ø16 M12	Ø20 M16
Tension service load in non cracked concrete:		[kN]	2.6	4.7	6.7	8.2	14.7
δ_{N0}	Displacement:	[mm]	1.8	1.9	2.3	1.8	1.7
$\delta_{N\infty}$		[mm]	2.5	2.6	3.0	2.5	2.4

W-HR sleeve anchor

Performances

Characteristic values for tension loads

Annex C2

English translation prepared by IETcc

Table C4: W-HR characteristic resistance values to shear loads of design method A according EN 1992-4

W-HR: characteristic resistances under shear loads			Performances				
			Ø8 M6	Ø10 M8	Ø12 M10	Ø16 M12	Ø20 M16
STEEL FAILURE WITHOUT LEVER ARM							
$V_{Rk,s}$	Characteristic resistance class 5.6:	[kN]	5.03	9.15	14.50	21.08	39.25
$\gamma_{M,s}$	Partial safety factor class 5.6:	[-]	1.67				
$V_{Rk,s}$	Characteristic resistance class 6.8:	[kN]	6.03	10.98	17.40	25.29	47.10
$\gamma_{M,s}$	Partial safety factor class 6.8:	[-]	1.25				
$V_{Rk,s}$	Characteristic resistance class 8.8:	[kN]	8.04	14.64	23.20	33.72	62.80
$\gamma_{M,s}$	Partial safety factor class 8.8:	[-]	1.25				
$V_{Rk,s}$	Characteristic resistance class 10.9:	[kN]	10.05	18.30	29.00	42.15	78.50
$\gamma_{M,s}$	Partial safety factor class 10.9:	[-]	1.50				
k_7	Ductility factor:	[-]	1.0				
STEEL FAILURE WITH LEVER ARM							
$M^0_{Rk,s}$	Characteristic bending moment 5.6:	[Nm]	7.63	18.75	37.41	65.55	166.61
$\gamma_{M,s}$	Partial safety factor 5.6:	[-]	1.67				
$M^0_{Rk,s}$	Characteristic bending moment 6.8:	[Nm]	9.16	22.50	44.89	78.66	199.93
$\gamma_{M,s}$	Partial safety factor 6.8:	[-]	1.25				
$M^0_{Rk,s}$	Characteristic bending moment 8.8:	[Nm]	12.21	30.00	59.86	104.88	266.57
$\gamma_{M,s}$	Partial safety factor 8.8:	[-]	1.25				
$M^0_{Rk,s}$	Characteristic bending moment 10.9	[Nm]	15.26	37.51	74.82	131.10	333.22
$\gamma_{M,s}$	Partial safety factor 10.9:	[-]	1.50				
CONCRETE PRYOUT FAILURE							
k_8	Pryout factor:	[-]	1.0	1.0	1.0	1.0	2.0
γ_{ins}	Installation safety factor:	[-]	1.0				
CONCRETE EDGE FAILURE							
l_f	Effective length of anchor:	[mm]	30	40	48	55	72
d_{nom}	Outside diameter of anchor:	[mm]	8	10	12	16	20
γ_{ins}	Installation safety factor:	[-]	1.0				

Table C5: W-HR displacements under shear loads

W-HR: displacements under shear loads		Performances					
		Ø8 M6	Ø10 M8	Ø12 M10	Ø16 M12	Ø20 M16	
Shear service load in non cracked concrete:	[kN]	3.5	6.3	9.9	14.5	26.9	
δ_{v0}	Displacement:	[mm]	1.9	2.8	2.8	2.9	3.8
$\delta_{v\infty}$		[mm]	2.9	3.8	4.2	4.4	6.7

W-HR sleeve anchor

Performances

Characteristic values for shear loads

Annex C3

English translation prepared by IETcc

Table C6: W-HR A2 characteristic resistance values to tension loads of design method A according to EN 1992-4

W-HR A2: characteristic resistances under tension loads		Performances					
		Ø8 M6	Ø10 M8	Ø12 M10	Ø16 M12	Ø20 M16	
STEEL FAILURE							
$N_{Rk,s}$	Characteristic resistance class A2-70: [kN]	14.07	25.62	40.60	59.01	109.90	
$\gamma_{M,s}$	Partial safety factor class: [-]	1.87					
PULL OUT FAILURE							
$N_{Rk,p}$	Characteristic resistance in C20/25 uncracked concrete: [kN]	--- ¹⁾	9,5	14	16	20	
γ_{ins}	Installation safety factor: [-]	1.0	1.2	1.2	1.2	1.0	
Ψ_c	Increasing factors for $N^0_{Rk,c}$:	C30/37	1.01	1.01	1.04	1.04	1.04
		C40/50	1.01	1.02	1.06	1.06	1.06
		C50/60	1.02	1.03	1.09	1.09	1.09
CONCRETE CONE FAILURE AND SPLITTING FAILURE							
h_{ef}	Effective anchorage depth: [mm]	30	40	48	55	72	
$k_{ucr,N}$	Factor for uncracked concrete: [-]	11.0					
γ_{ins}	Installation safety factor: [-]	1.0	1.2	1.2	1.2	1.2	
$s_{cr,N}$	Concrete cone Spacing: [mm]	3 x h_{ef}					
$c_{cr,N}$	failure: Edge distance: [mm]	1.5 x h_{ef}					
$s_{cr,sp}$	Splitting Spacing: [mm]	150	200	240	275	360	
$c_{cr,sp}$	failure: Edge distance: [mm]	75	100	120	138	180	

¹⁾ Pull out is not decisive

Table C7: W-HR A2 displacements under tension loads

W-HR A2: displacements under tension loads		Performances				
		Ø8 M6	Ø10 M8	Ø12 M10	Ø16 M12	Ø20 M16
Tension service load in non cracked concrete: [kN]		3.9	3.8	5.6	6.3	9.5
δ_{N0}	Displacement: [mm]	1.0	0.6	1.6	0.5	0.7
$\delta_{N\infty}$	[mm]	2.1				

W-HR A2 sleeve anchor

Performances

Characteristic values for tension loads

Annex C4

English translation prepared by IETcc

Table C8: W-HR A2 characteristic resistance values to shear loads of design method A according EN 1992-4

W-HR A2: characteristic resistances under shear loads		Performances				
		Ø8 M6	Ø10 M8	Ø12 M10	Ø16 M12	Ø20 M16
STEEL FAILURE WITHOUT LEVER ARM						
$V_{Rk,s}$	Characteristic resistance class A2-70: [kN]	7.04	12.81	20.30	29.51	54.95
$\gamma_{M,s}$	Partial safety factor class: [-]	1.56				
k_7	Ductility factor: [-]	1.0				
STEEL FAILURE WITH LEVER ARM						
$M^0_{Rk,s}$	Characteristic bending moment A2-70: [Nm]	10.7	22.5	44.9	78.6	199.8
$\gamma_{M,s}$	Partial safety factor: [-]	1.56				
CONCRETE PRYOUT FAILURE						
k_8	Pryout factor: [-]	1.0	1.0	1.0	1.0	2.0
γ_{ins}	Installation safety factor: [-]	1.0				
CONCRETE EDGE FAILURE						
l_f	Effective length of anchor: [mm]	30	40	48	55	72
d_{nom}	Outside diameter of anchor: [mm]	8	10	12	16	20
γ_{ins}	Installation safety factor: [-]	1.0				

Table C9: W-HR A2 displacements under shear loads

W-HR A2: displacements under shear loads		Performances				
		Ø8 M6	Ø10 M8	Ø12 M10	Ø16 M12	Ø20 M16
Shear service load in non cracked concrete: [kN]		3.2	5.9	9.3	13.5	25.2
δ_{v0}	Displacement: [mm]	1.7	1.8	1.7	1.3	1.6
$\delta_{v\infty}$	Displacement: [mm]	2.6	2.7	2.5	1.9	2.4

W-HR A2 sleeve anchor	Annex C5
Performances	
Characteristic values for shear loads	