

Designated  
according to  
Article 29 of  
Regulation (EU)  
N° 305/2011



Member of

www.eota.eu

**INSTITUTO DE CIENCIAS  
DE LA CONSTRUCCIÓN  
EDUARDO TORROJA**

C/ Serrano Galvache n. 4 28033 Madrid (Spain)  
Tel.: (34) 91 302 04 40 Fax: (34) 91 302 07 00  
[direccion.ietcc@csic.es](mailto:direccion.ietcc@csic.es) <https://dit.ietcc.csic.es>

## European Technical Assessment

## ETA 20/0632 of 31/07/2020

English translation prepared by IETcc. Original version in Spanish language

### General Part

**Technical Assessment Body issuing the ETA designated according to Art. 29 of Regulation (EU) 305/2011:**

Instituto de Ciencias de la Construcción Eduardo Torroja (IETcc)

**Trade name of the construction product:**

**Parabolt V2x2xx  
Parabolt V2x3xx  
Parabolt V2x4xx**

**Product family to which the construction product belongs:**

Torque controlled expansion anchor made of galvanised steel or stainless steel of sizes M6, M8, M10, M12, M14, M16 and M20 for use in non-cracked concrete.

**Manufacturer:**

**Fixe Climbing S.L.**  
Jeroni Guixá, 1  
08580 Sant Quirzè de Besora  
Barcelona. España  
Webpage: [www.fixeclimbing.com](http://www.fixeclimbing.com)

**Manufacturing plants:**

Fixe plant 1  
Fixe plant 2

**This European Technical Assessment contains:**

13 pages including 4 annexes which form an integral part of this assessment.

**This European Technical Assessment is issued in accordance with regulation (EU) No 305/2011, on the basis of:**

European Technical Assessment EAD 330232-00-0601 "Mechanical Fasteners for use in concrete", ed. October 2016

*English translation prepared by IETcc*

This European Technical Assessment is issued by the Technical Assessment Body in its official language. Translations of this European Technical Assessment in other languages shall fully correspond to the original issued document and should be identified as such.

This European Technical Assessment may be withdrawn by the issuing Technical Assessment Body, in particular pursuant to information by the Commission according to article 25 (3) of Regulation (EU) No 305/2011.

## SPECIFIC PART

### 1. Technical description of the product

The Fixe V2x2xx in the range of M6, M8, M10, M12, M14, M16 and M20 is an anchor made of galvanised steel. The Fixe V2x3xx and V2x4xx in the range of M6, M8, M10, M12, M16 and M20 are anchors made of stainless steel of grades A2 and A4 respectively. The anchor is installed into a predrilled cylindrical hole and anchored by torque-controlled expansion. The anchorage is characterised by friction between expansion clip and concrete.

Product and installation descriptions are given in annexes A1 and A2.

### 2. Specification of the intended use in accordance with the applicable European Assessment Document.

The performances given in section 3 are only valid if the anchor is used in compliance with the specifications and conditions given in annex B.

The verifications and assessment methods on which this European Technical Assessment is based lead to the assumption of a working life of the anchor of at least 50 years. The indications given on the working life cannot be interpreted as a guarantee given by the producer, but are to be regarded only as a mean to choosing the right products in relation to the expected economically reasonable working life of the works.

### 3. Performance of the product and references to the methods used for its assessment

#### 3.1 Mechanical resistance and stability (BWR 1)

Essential characteristic	Performance
V2x2xx product performance for static or quasi static actions	See annex C
V2x3xx and V2x4x product performance for static or quasi static actions	See annex D

#### 3.2 Safety in case of fire (BWR 2)

Essential characteristic	Performance
Reaction to fire	Anchorage satisfies requirements for class A1
Resistance to fire	No performance assessed

### 4. Assessment and verification of constancy of performance (hereinafter AVCP) system applied, with reference to its legal base

The applicable European legal act for the system of Assessment and Verification of Constancy of Performances (see annex V of Regulation (EU) No 305/2011) is 96/582/EC.

The system to be applied is 1.

English translation prepared by IETcc

**5. Technical details necessary for the implementation of the AVCP system, as provided for in the applicable European Assessment Document.**

The technical details necessary for the implementation of the AVCP system are laid down in the quality plan deposited at Instituto de Ciencias de la Construcción Eduardo Torroja.



Instituto de Ciencias de la Construcción Eduardo Torroja  
CONSEJO SUPERIOR DE INVESTIGACIONES CIENTÍFICAS

C/ Serrano Galvache n.º 4. 28033 Madrid.  
Tel: (+34) 91 302 04 40 Fax. (+34) 91 302 07 00  
<https://dit.ietcc.csic.es>



On behalf of the Instituto de Ciencias de la Construcción Eduardo Torroja  
Madrid, 31<sup>st</sup> of July 2020



Director IETcc - CSIC

**Product and identification**

V2x2xx, V2x3xx, V2x4xx anchor



Identification on anchor:

- Expansion clip:
  - Anchor V2x2xx: Company logo + “ZN” + Metric size.
  - Anchor V2x3xx: Company logo + “304” + Metric size.
  - Anchor V2x4xx: Company logo + “316” + Metric size.
- Anchor body: Metric x Length
- Red ring marks to show embedment depths
- Anchor length letter code on the tip:

Letter code	Length [mm]
B	51 ÷ 62
C	63 ÷ 75
D	76 ÷ 88
E	89 ÷ 101
F	102 ÷ 113
G	114 ÷ 126
H	127 ÷ 139
I	140 ÷ 151
J	152 ÷ 164
K	165 ÷ 177
L	178 ÷ 190
M	191 ÷ 202
N	203 ÷ 215
P	229 ÷ 240
Q	241 ÷ 253
R	254 ÷ 266
S	267 ÷ 300

V2x2xx, V2x3xx, V2x4xx anchor

Product description

Identification

Annex A1

English translation prepared by IETcc

**Installed condition**

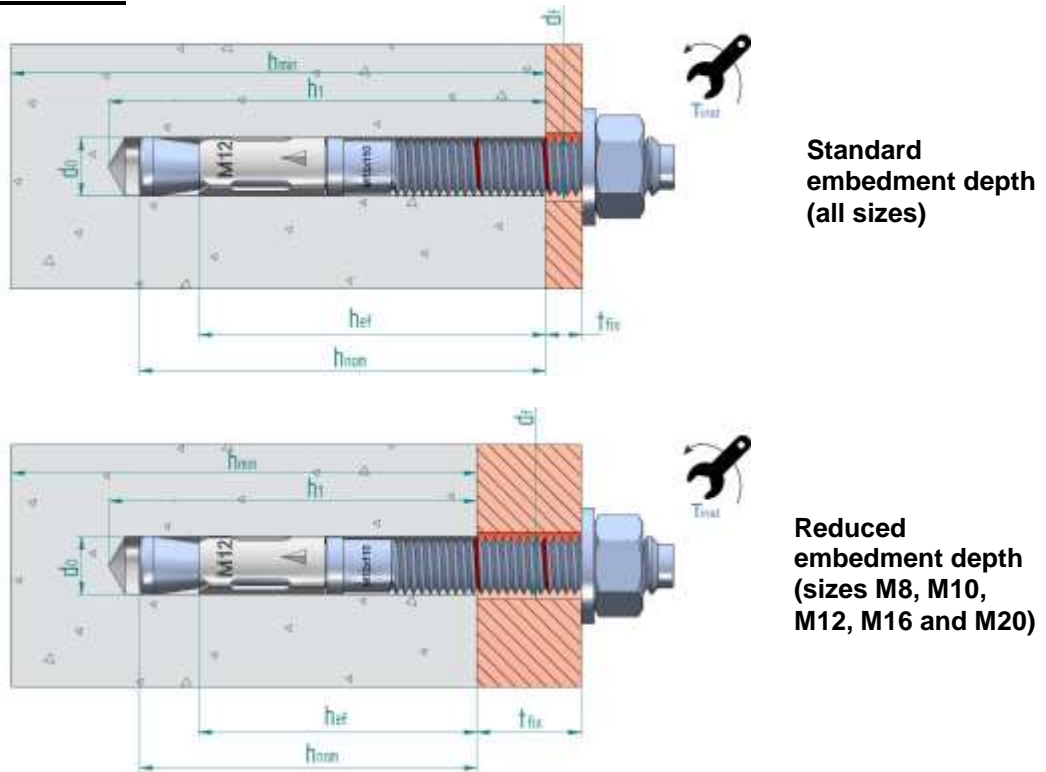

- $d_0$ : Nominal diameter of drill bit
- $d_r$ : Fixture clearance hole diameter
- $h_{ef}$ : Effective anchorage depth
- $h_1$ : Depth of drilled hole
- $h_{nom}$ : Overall anchor embedment depth in the concrete
- $h_{min}$ : Minimum thickness of concrete member
- $t_{fix}$ : Fixture thickness
- $T_{ins}$ : Installation torque

**Table A1: Materials**

Item	Designation	Material for V2x2xx	Material for V2x3xx	Material for V2x4xx
1	Anchor Body	Carbon steel galvanised $\geq 5 \mu\text{m}$ ISO 4042 A2, cold forged	Stainless steel, grade A2	Stainless steel, grade A4
2	Washer	DIN 125, DIN 9021 or DIN 440 galvanised $\geq 5 \mu\text{m}$ ISO 4042 A2	DIN 125, DIN 9021 or DIN 440, stainless steel grade A2	DIN 125, DIN 9021 or DIN 440, stainless steel grade A4
3	Nut	DIN 934 class 6 galvanised $\geq 5 \mu\text{m}$ ISO 4042 A2, class 6	DIN 934, stainless steel grade A2	DIN 934, stainless steel grade A4
4	Expansion clip	Carbon steel galvanised $\geq 5 \mu\text{m}$ ISO 4042 A2	Stainless steel, grade A2	Stainless steel, grade A4

**V2x2xx, V2x3xx, V2x4xx anchor**

**Product description**

Installed condition and materials

**Annex A2**

English translation prepared by IETcc

### **Intended use**

#### **Anchorage subjected to:**

- Static or quasi static loads: all sizes and embedment depths

#### **Base materials:**

- Reinforced and unreinforced concrete according to EN 206-1:2013
- Strength classes C20/25 to C50/60 according to EN 206-1:2013
- Uncracked concrete

#### **Use conditions (environmental conditions):**

- The anchor shall be used in dry internal conditions: all anchor types
- Structural subjected to external atmospheric exposure (including industrial and marine environment) and to permanent internal conditions with no particular aggressive conditions exists: screw types made of stainless steel with marking A4. Such particular aggressive conditions are e.g. permanent, alternating immersion in seawater or the splash zone of seawater, chloride atmosphere of indoor swimming pools or atmosphere with extreme chemical pollution (e.g. in desulphurization plants or road tunnels where de-icing materials are used).

#### **Design:**

- Anchorages are designed under the responsibility of an engineer experienced in anchorages and concrete.
- Verifiable calculation rules and drawings are prepared taking into account of the loads to be attached. The position of the anchor is indicated on the design drawings (e.g. position of the anchor relative to reinforcement or to supports, etc.)
- Anchorages under static or quasi-static loads are designed for design Method A in accordance with EN 1992-4:2018
- Size M8 in reduced embedment depth is restricted to anchoring of structural components which are statically indeterminate.

#### **Installation:**

- Hammer drilling only.
- Anchor installation carried out by appropriately qualified personal and under the supervision of the person responsible for technical matters of the site.
- In case of aborted hole: new drilling at a minimum distance away of twice the depth of aborted hole or smaller distance if the aborted hole is filled with high strength mortar and if under shear or oblique tension load it is not the direction of the load application.

**V2x2xx, V2x3xx, V2x4xx anchor**

**Intended use**

Specifications

**Annex B1**

English translation prepared by IETcc

**Table C1: Installation parameters for V2x2xx anchor**

V2x2xx: GALVANISED ANCHOR: Installation parameters			Performances						
			M6	M8	M10	M12	M14	M16	M20
$d_0$	Nominal diameter of drill bit:	[mm]	6	8	10	12	14	16	20
$d_f$	Fixture clearance hole diameter:	[mm]	7	9	12	14	16	18	22
$T_{inst}$	Nominal installation torque:	[Nm]	7	20	35	60	90	120	240
<b>Standard embedment depth</b>									
$L_{min}$	Minimum length of the bolt:	[mm]	60	75	85	100	115	125	160
$h_{min}$	Minimum thickness of concrete member:	[mm]	100	100	110	130	150	168	206
$h_1$	Depth of drilled hole $\geq$	[mm]	55	65	75	85	100	110	135
$h_{nom}$	Overall anchor embed depth in concrete:	[mm]	49.5	59.5	66.5	77	91	103.5	125
$h_{ef, std}$	Effective anchorage depth:	[mm]	40	48	55	65	75	84	103
$t_{fix}$	Thickness of fixture for DIN 125 washer $\leq$	[mm]	L-58	L-70	L-80	L-92	L-108	L-122	L-147
$t_{fix}$	Thickness of fixture for DIN 9021 or DIN 440 washer $\leq$	[mm]	L-58	L-71	L-80	L-94	L-108	L-124	L-149
$s_{min}$	Minimum allowable spacing:	[mm]	35	40	50	70	80	90	135
$c_{min}$	Minimum allowable distance:	[mm]	35	40	50	70	80	90	135
<b>Reduced embedment depth</b>									
$L_{min}$	Minimum length of the bolt:	[mm]	--	60	70	80	--	110	130
$h_{min}$	Minimum thickness of concrete member:	[mm]	--	100	100	100	--	130	150
$h_1$	Depth of drilled hole:	[mm]	--	50	60	70	--	90	107
$h_{nom}$	Overall anchor embed depth in concrete:	[mm]	--	46.5	53.5	62	--	84.5	97
$h_{ef, red}$	Effective anchorage depth:	[mm]	--	35	42	50	--	65	75
$t_{fix}$	Thickness of fixture for DIN 125 washer $\leq$	[mm]	--	L-57	L-67	L-77	--	L-103	L-121
$t_{fix}$	Thickness of fixture for DIN 9021 or DIN 440 washer $\leq$	[mm]	--	L-58	L-67	L-79	--	L-105	L-123
$s_{min}$	Minimum allowable spacing:	[mm]	--	40	50	70	--	90	135
$c_{min}$	Minimum allowable distance:	[mm]	--	40	50	70	--	90	135

**Installation process**

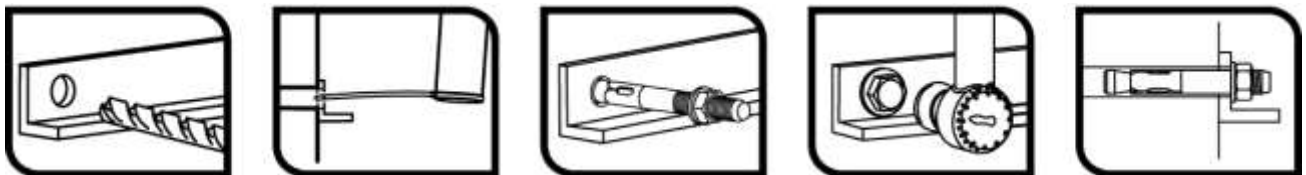

V2x2xx anchor

Performances

Installation parameters and installation procedure

**Annex C1**



English translation prepared by IETcc

**Table C2: Characteristic resistance values to tension loads of design method A according to EN 1992-4 for V2x2xx anchor**

V2x2xx: GALVANISED ANCHOR		Performances							
		M6	M8	M10	M12	M14	M16	M20	
<b>STEEL FAILURE</b>									
$N_{Rk,s}$	Characteristic resistance:	[kN]	7.4	13.0	23.7	33.3	49.1	60.1	99.5
$\gamma_{M,s}$	Partial safety factor:	[-]	1.40	1.40	1.40	1.40	1.40	1.40	1.40
<b>PULL OUT FAILURE</b>									
<b>Standard embedment depth</b>									
$N_{Rk,p}$	Characteristic resistance in C20/25 uncracked concrete:	[kN]	-- <sup>1)</sup>	-- <sup>1)</sup>	19.0	-- <sup>1)</sup>	-- <sup>1)</sup>	-- <sup>1)</sup>	-- <sup>1)</sup>
$\gamma_{ins}$	Installation safety factor:	[-]	1.0						
$\Psi_c$	Increasing factors for $N^0_{Rk,p}$ :	C30/37	1.22						
		C40/50	1.41						
		C50/60	1.58						
<b>Reduced embedment depth</b>									
$N_{Rk,p}$	Characteristic resistance in C20/25 uncracked concrete:	[kN]	--	10	-- <sup>1)</sup>	-- <sup>1)</sup>	--	-- <sup>1)</sup>	-- <sup>1)</sup>
$\gamma_{ins}$	Installation safety factor:	[-]	--	1.0		--	1.0		
$\Psi_c$	Increasing factors for $N^0_{Rk,p}$ :	C30/37	--	1.22		--	1.22		
		C40/50	--	1.41		--	1.41		
		C50/60	--	1.58		--	1.58		
<b>CONCRETE CONE FAILURE AND SPLITTING FAILURE</b>									
<b>Standard embedment depth</b>									
$h_{ef, std}$	Effective anchorage depth:	[mm]	40	48	55	65	75	84	103
$k_{ucr, N}$	Factor for uncracked concrete:	[-]	11.0						
$\gamma_{ins}$	Installation safety factor:	[-]	1.0						
$S_{cr, N}$	Concrete cone failure:	[mm]	3 x $h_{ef}$						
$C_{cr, N}$		[mm]	1.5 x $h_{ef}$						
$S_{cr, sp}$	Splitting failure:	[mm]	160	192	220	260	300	280	360
$C_{cr, sp}$		[mm]	80	96	110	130	150	140	180
<b>Reduced embedment depth</b>									
$h_{ef, std}$	Effective anchorage depth:	[mm]	--	35	42	50	--	65	75
$k_{ucr, N}$	Factor for uncracked concrete:	[-]	--	11.0		--	11.0		
$\gamma_{ins}$	Installation safety factor:	[-]	--	1.0		--	1.0		
$S_{cr, N}$	Concrete cone failure	[mm]	--	3 x $h_{ef}$		--	3 x $h_{ef}$		
$C_{cr, N}$		[mm]	--	1.5 x $h_{ef}$		--	1.5 x $h_{ef}$		
$S_{cr, sp}$	Splitting failure:	[mm]	--	140	168	200	--	260	300
$C_{cr, sp}$		[mm]	--	70	84	100	--	130	150

<sup>1)</sup> Pull out failure is not decisive

V2x2xx anchor

Performances

Characteristic values for tension loads

Annex C2

**Table C3: Characteristic resistance values to shear loads of design method A according to EN 1992-4 for V2x2xx anchor**

V2x2xx: GALVANISED ANCHOR		Performances							
		M6	M8	M10	M12	M14	M16	M20	
<b>STEEL FAILURE WITHOUT LEVER ARM</b>									
$V_{Rk,s}$	Characteristic resistance:	[kN]	5.1	9.3	14.7	20.6	28.1	38.4	56.3
$k_7$	Ductility factor:	[-]	1.0						
$\gamma_{M,s}$	Partial safety factor:	[-]	1.25						
<b>STEEL FAILURE WITH LEVER ARM</b>									
$M^0_{Rk,s}$	Characteristic bending moment:	[Nm]	7.7	19.1	38.1	64.1	102.2	163.1	298.5
$\gamma_{M,s}$	Partial safety factor:	[-]	1.25						
<b>CONCRETE PRYOUT FAILURE</b>									
$k_8$	Pry out factor:	for $h_{ef,std}$	1.0	1.0	1.0	2.0	2.0	2.0	2.0
		for $h_{ef,red}$	--	1.0	1.0	1.0	--	2.0	2.0
$\gamma_{ins}$	Installation safety factor:	[-]	1.0						
<b>CONCRETE EDGE FAILURE</b>									
$l_f$	Effective length of anchor:	for $h_{ef,std}$	40	48	55	65	75	84	103
		for $h_{ef,red}$	--	35	42	50	--	65	75
$d_{nom}$	Outside diameter of anchor:	[mm]	6	8	10	12	14	16	20
$\gamma_{ins}$	Installation safety factor:	[-]	1.0						

**Table C4: Displacements under tension loads for V2x2xx**

V2x2xx: GALVANISED ANCHOR		Performances							
		M6	M8	M10	M12	M14	M16	M20	
<b>Standard embedment depth</b>									
Tension load in non cracked concrete:		[kN]	3.8	6.6	9.0	12.6	15.6	18.5	25.1
$\delta_{N0}$	Displacement:	[mm]	0.4	0.7	1.0	1.2	1.3	1.9	2.2
$\delta_{N\infty}$		[mm]	1.8	2.1	2.4	2.6	2.7	3.3	3.8
<b>Reduced embedment depth</b>									
Tension load in non cracked concrete:		[kN]	--	4.8	6.5	8.5	--	12.6	15.6
$\delta_{N0}$	Displacement:	[mm]	--	0.3	0.6	1.0	--	1.6	1.9
$\delta_{N\infty}$		[mm]	--	1.4	1.7	2.1	--	2.7	3.0

**Table C5: Displacements under shear loads for V2x2xx**

V2x2xx: GALVANISED ANCHOR		Performances							
		M6	M8	M10	M12	M14	M16	M20	
<b>Standard embedment depth</b>									
Shear load in non cracked concrete:		[kN]	2.9	5.3	8.4	11.8	16.0	21.9	32.1
$\delta_{V0}$	Displacement:	[mm]	0.65	2.80	1.75	2.45	2.78	3.53	4.13
$\delta_{V\infty}$		[mm]	0.98	4.20	2.63	3.68	4.16	5.29	6.19
<b>Reduced embedment depth</b>									
Shear load in non cracked concrete:		[kN]	--	5.3	8.4	11.8	--	21.9	32.1
$\delta_{V0}$	Displacement:	[mm]	--	0.59	1.22	1.10	--	3.10	3.40
$\delta_{V\infty}$		[mm]	--	0.89	1.83	1.65	--	4.60	5.10

<b>V2x2xx anchor</b>	<b>Annex C3</b>
<b>Performances</b>	
Characteristic values for shear loads Displacements under tension and shear loads	

English translation prepared by IETcc

**Table D1: Installation parameters for V2x3xx, V2x4xx anchor**

V2x3xx, V2x4xx: STAINLESS STEEL ANCHOR: Installation parameters		Performances					
		M6	M8	M10	M12	M16	M20
$d_0$	Nominal diameter of drill bit: [mm]	6	8	10	12	16	20
$d_f$	Fixture clearance hole diameter: [mm]	7	9	12	14	18	22
$T_{inst}$	Nominal installation torque: [Nm]	7	20	35	60	120	240
<b>Standard embedment depth</b>							
$L_{min}$	Minimum length of the bolt: [mm]	60	75	85	100	125	160
$h_{min}$	Minimum thickness of concrete member: [mm]	100	100	110	130	168	206
$h_1$	Depth of drilled hole $\geq$ [mm]	55	65	75	85	110	135
$h_{nom}$	Overall anchor embed depth in concrete: [mm]	49.5	59.5	66.5	77	103.5	125
$h_{ef, std}$	Effective anchorage depth: [mm]	40	48	55	65	84	103
$t_{fix}$	Thickness of fixture for DIN 125 washer $\leq$ [mm]	L-58	L-70	L-80	L-92	L-122	L-147
$t_{fix}$	Thickness of fixture for DIN 9021 or DIN 440 washer $\leq$ [mm]	L-58	L-71	L-80	L-94	L-124	L-149
$S_{min}$	Minimum allowable spacing: [mm]	50	65	70	85	110	135
$C_{min}$	Minimum allowable distance: [mm]	50	65	70	85	110	135
<b>Reduced embedment depth</b>							
$L_{min}$	Minimum length of the bolt: [mm]	--	60	70	80	--	--
$h_{min}$	Minimum thickness of concrete member: [mm]	--	100	100	100	--	--
$h_1$	Depth of drilled hole: [mm]	--	50	60	70	--	--
$h_{nom}$	Overall anchor embed depth in concrete: [mm]	--	46.5	53.5	62	--	--
$h_{ef, red}$	Effective anchorage depth: [mm]	--	35	42	50	--	--
$t_{fix}$	Thickness of fixture for DIN 125 washer $\leq$ [mm]	--	L-57	L-67	L-77	--	--
$t_{fix}$	Thickness of fixture for DIN 9021 or DIN 440 washer $\leq$ [mm]	--	L-58	L-67	L-79	--	--
$S_{min}$	Minimum allowable spacing: [mm]	--	65	70	85	--	--
$C_{min}$	Minimum allowable distance: [mm]	--	65	70	85	--	--

**Installation process**

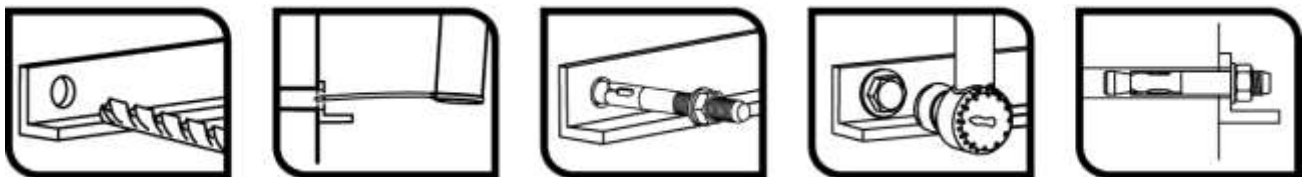

V2x3xx, V2x4xx anchor

Performances

Installation parameters and installation procedure

Annex D1

English translation prepared by IETcc

**Table D2: Characteristic resistance values to tension loads of design method A according to EN 1992-4 for V2x3xx, V2x4xx anchor**

V2x3xx, V2x4xx: STAINLESS STEEL ANCHOR		Performances						
		M6	M8	M10	M12	M16	M20	
<b>STEEL FAILURE</b>								
$N_{Rk,s}$	Characteristic resistance:	[kN]	10.1	19.1	34.3	49.6	85.9	140.7
$\gamma_{M,s}$	Partial safety factor:	[-]	1.68					
<b>PULL OUT FAILURE</b>								
<b>Standard embedment depth</b>								
$N_{Rk,p}$	Characteristic resistance in C20/25 uncracked concrete:	[kN]	-- <sup>1)</sup>	12	16	25	35	50
$\gamma_{ins}$	Installation safety factor:	[-]	--	1.0	1.2			
<b>Reduced embedment depth</b>								
$N_{Rk,p}$	Characteristic resistance in C20/25 uncracked concrete:	[kN]	--	9	12	16	--	--
$\gamma_{ins}$	Installation safety factor:	[-]	--	1.2		--	--	
$\Psi_c$	Increasing factors for $N^0_{Rk,p}$ :	C30/37	1.22					
		C40/50	1.41					
		C50/60	1.58					
<b>CONCRETE CONE FAILURE AND SPLITTING FAILURE</b>								
<b>Standard embedment depth</b>								
$h_{ef, std}$	Effective anchorage depth:	[mm]	40	48	55	65	84	103
$k_{ucr, N}$	Factor for uncracked concrete:	[-]	11.0					
$\gamma_{ins}$	Installation safety factor:	[-]	1.0		1.2			
$S_{cr, N}$	Concrete cone failure:	[mm]	3 x $h_{ef}$					
$C_{cr, N}$		[mm]	1.5 x $h_{ef}$					
$S_{cr, sp}$	Splitting failure:	[mm]	160	192	220	260	336	412
$C_{cr, sp}$		[mm]	80	96	110	130	168	206
<b>Reduced embedment depth</b>								
$h_{ef, std}$	Effective anchorage depth:	[mm]	--	35	42	50	--	--
$k_{ucr, N}$	Factor for uncracked concrete:	[-]	11.0					
$\gamma_{ins}$	Installation safety factor:	[-]	--	1.2		--	--	
$S_{cr, N}$	Concrete cone failure:	[mm]	--	3 x $h_{ef}$			--	--
$C_{cr, N}$		[mm]	--	1.5 x $h_{ef}$			--	--
$S_{cr, sp}$	Splitting failure:	[mm]	--	140	168	200	--	--
$C_{cr, sp}$		[mm]	--	70	84	100	--	-

<sup>1)</sup> Pull out failure is not decisive

V2x3xx, V2x4xx anchor

Performances

Characteristic values for tension loads

Annex D2

English translation prepared by IETcc

**Table D3: Characteristic resistance values to shear loads of design method A according to EN 1992-4 for V2x3xx, V2x4xx anchor**

V2x3xx, V2x4xx: STAINLESS STEEL ANCHOR				Performances					
				M6	M8	M10	M12	M16	M20
<b>STEEL FAILURE WITHOUT LEVER ARM</b>									
$V_{Rk,s}$	Characteristic resistance:	[kN]	6.0	10.9	17.4	25.2	47.1	73.5	
$k_7$	Ductility factor:	[-]	1.0						
$\gamma_{M,s}$	Partial safety factor	[-]	1.52						
<b>STEEL FAILURE WITH LEVER ARM</b>									
$M^0_{Rk,s}$	Characteristic bending moment:	[Nm]	9.2	22.5	44.9	78.6	200	389	
$\gamma_{M,s}$	Partial safety factor:	[-]	1.52						
<b>CONCRETE PRYOUT FAILURE</b>									
$k_8$	Pry out factor:	for $h_{ef, std}$	[-]	1.0	1.0	1.0	2.0	2.0	2.0
		for $h_{ef, red}$	[-]	--	1.0	1.0	1.0	--	--
$\gamma_{ins}$	Installation safety factor:	[-]	1.0						
<b>CONCRETE EDGE FAILURE</b>									
$l_f$	Effective length of anchor under shear loads:	for $h_{ef, std}$	[mm]	40	48	55	65	84	103
		for $h_{ef, red}$	[mm]	--	35	42	50	--	--
$d_{nom}$	Outside diameter of anchor:	[mm]	6	8	10	12	16	20	
$\gamma_{ins}$	Installation safety factor:	[-]	1.0						

**Table D4: Displacements under tension loads for V2x3xx, V2x4xx**

V2x3xx, V2x4xx: STAINLESS STEEL ANCHOR				Performances					
				M6	M8	M10	M12	M16	M20
<b>Standard embedment depth</b>									
Tension load in non cracked concrete:			[kN]	4.3	5.7	6.3	9.9	13,8	19.8
$\delta_{N0}$	Displacement:	[mm]	0.42	0.22	0.17	0.19	0.19	0.11	
$\delta_{N\infty}$		[mm]	1.33	1.33	1.33	1.33	1.33	1.33	
<b>Reduced embedment depth</b>									
Tension load in non cracked concrete:			[kN]	--	4.2	5.7	7.6	--	--
$\delta_{N0}$	Displacement:	[mm]	--	0.07	0.04	0.32	--	--	
$\delta_{N\infty}$		[mm]	--	0.60	0.60	0.60	--	--	

**Table D5: Displacements under shear loads for V2x3xx, V2x4xx**

V2x3xx, V2x4xx: STAINLESS STEEL ANCHOR				Performances					
				M6	M8	M10	M12	M16	M20
<b>Standard embedment depth</b>									
Shear load in non cracked concrete:			[kN]	2.8	5.1	8.1	11.8	22.1	34.5
$\delta_{V0}$	Displacement:	[mm]	1.66	1.79	3.83	4.13	5.75	6.59	
$\delta_{V\infty}$		[mm]	2.49	2.68	5.74	6.19	8.62	9.88	
<b>Reduced embedment depth</b>									
Shear load in non cracked concrete:			[kN]	--	5.1	8.1	11.8	--	--
$\delta_{V0}$	Displacement:	[mm]	--	0.60	3.83	4.13	--	--	
$\delta_{V\infty}$		[mm]	--	0.90	5.74	6.19	--	--	

**V2x3xx, V2x4xx anchor**

**Performances**

Characteristic values for shear loads  
Displacements under tension and shears

**Annex D3**