

**INSTITUTO DE CIENCIAS
DE LA CONSTRUCCIÓN
EDUARDO TORROJA**

C/ Serrano Galvache 4. 28033 Madrid (Spain).
Tel: (+34) 91 302 0440.
direccion.ietcc@csic.es. <https://dit.ietcc.csic.es>

European Technical Assessment

ETA 15 / 0655 of 23/04/2021

English translation prepared by IETcc. Original version in Spanish language

General Part

Technical Assessment Body issuing the ETA:

Instituto de Ciencias de la Construcción Eduardo Torroja (IETcc)

Trade name of the construction product:

STB-REM, STB -T-REM, STB-CH, STB-T-CH, STB-SZ, STB-T-SZ (kits based on TMCP stacbond® PE, stacbond® FR and stacbond® A2)

Product family to which the construction product belongs:

Kits for external wall claddings mechanically fixed

Manufacturer:

STAC S.L.
Polígono Industrial de Picusa – La Matanza, s/n
15900 Padrón (A Coruña). Spain
www.stac.es

Manufacturing plant(s):

STAC S.L.
Ctra Perandones s/n
Polígono Ind.La Rozada. Toral de los Vados.
24560 Toral de los Vados. (León). Spain

This European Technical Assessment contains:

27 pages including 3 Annexes which form an integral part of the assessment. Annex C contains confidential information and is not included in the ETA when is publicly available.

This European Technical Assessment is issued in accordance with regulation (EU) No 305/2011, on the basis of:

European Assessment Document (EAD) 090062-00-0404. Ed. July 2018. Kits for external wall claddings mechanically fixed

This ETA is a corrigendum of:

ETA 15/0655 version 5 issued on the 20/01/2021

Translations of this European Technical Assessment in other languages shall fully correspond to the original issued document and shall be identified as such.

Communication of this European Technical Assessment, including transmission by electronic means, shall be in full (excepted Annex(es) referred to as confidential(s)). However, partial reproduction may be made, with the written consent of the issuing Technical Assessment Body. Any partial reproduction has to be identified as such.

SPECIFIC PARTS

1. Technical description of the product (kit)

The assessed kits for ventilated external wall claddings mechanically fixed are “STB-REM” and “STB-T-REM” (family A), “STB-CH” and “STB-T-CH” (family G), “STB-SZ” and “STB –T-SZ” (family C) ⁽¹⁾. All claddings (thin metallic composite panels “stacbond® PE”, “stacbond® FR”, and “stacbond® A2”) are manufactured by the ETA-holder. These claddings are mechanically fastened to their subframes, fixed to the external walls of new or existing buildings (retrofit). An insulation layer can be fixed on the external wall. The kits comprise other components as specified in Table 0, which are factory produced by the ETA – holder or by suppliers.

Table 0 – Definition of components of the kit				
Component	Kit	Material (Reference)	Size (mm) [Tolerances]	
Subframe elements	Vertical and if required, horizontal profiles used to fix the cladding elements	STB REM	<u>Ref.05.19.003 / 05.19.040</u> : Ω-shape section vertical or horizontal profiles made of raw finished extruded alloyed aluminium 6063 T5/T6	Length: ≥ 6000
		STB T REM	<u>Ref. 05.19.043</u> : T-shape section vertical or horizontal profiles made of raw finished extruded alloyed aluminium 6063 T5/T6 <u>Ref. 05.19.054</u> , and <u>ref. 05.19.055</u> : L-shape section vertical or horizontal profiles made of raw finished extruded alloyed aluminium 6063 T5/T6 – only for borders of façade	
		STB-CH	<u>Ref.05.19.003 /05.19.040</u> : Same profile described above	
		STB-T-CH	<u>Ref. 05.19.061</u> : T-shape section vertical or horizontal profiles made of raw finished extruded alloyed aluminium 6063 T5/T6	Thickness: ≥ 2,0, except for ref. 05.19.043 (≥ 1,8) Ref. 05.19.040, 05.19.053, 05.19.055 Thickness: ≥2,5
		STB-SZ	<u>Ref.05.19.001</u> : S-shape section profiles made of raw finished extruded alloyed aluminium 6063 T5/T6 <u>Ref.05.19.002</u> : Z-shape section profiles made of raw finished extruded alloyed aluminium 6063 T5/T6 <u>Ref.05.19.063</u> : Z-shape section profiles made of raw finished extruded alloyed aluminium 6063 T5/T6 - horizontal joints 20 mm. <u>Ref.05.19.074</u> : Z-shape section profiles made of raw finished extruded alloyed aluminium 6063 T5/T6 - horizontal joints 24 mm. <u>Ref.05.19.003 /05.19.040</u> : Same profile described above	
		STB-T-SZ	<u>Ref.05.19.001</u> : Same profile described above <u>Ref.05.19.002</u> : Same profile described above <u>Ref.05.19.063</u> : Same profile described above <u>Ref.05.19.074</u> : Same profile described above <u>Ref. 05.19.043 / 05.19.053</u> : Same profile described above <u>Ref. 05.19.054</u> , and <u>ref. 05.19.055</u> : L-shape section vertical or horizontal profiles made of raw finished extruded alloyed aluminium 6063 T5/T6 – only for borders of façade	
Cladding	Riveted boards (family A)	STB REM	<u>stacbond® PE</u> : Composed by two external alloyed aluminium sheets EN AW 3005 H42/H44 or 3105 H42/H44/H46 or 5005 H42/H44 (painted) and an internal core made of recycled low density polyethylene (LDPE).	Standard length: 3200, 4000, 5000, 6000 Tol: [0.0 /+3] Standard width: 1000,1250, 1500,1600, 2000 Tol: [0.0 /+2] Standard thickness: 4 Tolerances: [± 0,15;+0,1]
		STB-T-REM	<u>stacbond® FR</u> : Composed by two external alloyed aluminium sheets EN AW 3005 H42/H44 or 3105 H42/H44/H46 or 5005 H42/H44 (painted) and an internal core made mainly of mineral compounds, and recycled low density polyethylene (LDPE) plus	
	Suspended cassettes (family G)	STB-CH STB-T-CH	Cassettes with top horizontal double folded flange, bottom horizontal simple/double folded flange. Lateral simple folded flanges 40 mm depth (reinforced slot width 10,5 mm) or 44,5 mm depth (not reinforced slots width 15 mm), made from stacbond® PE, stacbond® FR or stacbond® A2, described above	
Fixed cassettes (family C)	STB-SZ STB-T-SZ	Cassettes with lateral simple folded flanges ≥ 30 mm depth, top horizontal folded flange, and bottom horizontal simple folded flange made from stacbond® PE, stacbond® FR or stacbond® A2, described above.		

(1) Families described at Table 1.1 of EAD 090062-00-0404 ed.July 2018 (hereafter EAD) .

Table 0 – Definition of components of the kit (continuation)

Component		Kit	Material (Reference)	Size (mm) [Tolerances]		
Fixings ⁽²⁾	Elements used to fix cladding and/or subframe elements	STB REM STB-T-REM	<u>Blind rivet 5.0 x 12 Al/inox (AlMg5) (d_k=14 mm)</u> : Open end blind rivet, with A2 stainless steel break pull mandrel diameter d= 5 mm and length 12 mm, and protruding aluminium head (optionally lacquered) i.e.: SFS AP14-S-50120 Optionally: Self screwing screw 4.8x19 stainless steel i.e. SLA3/6-D12-4,8x19 A2	--		
		STB - REM	<u>Ref.05.19.020</u> : T-Profile made of folded sheets alloyed aluminium 1050 H for joining the vertical and horizontal profiles, plus the following rivets or screws: - Open blind rivets 4,8x15 with A2 stainless steel break pull mandrel diameter i.e. SFS Polygrip ASO-D-48150 - Self screwing screw of stainless steel A2 4,8x19	Thickness: 3 mm		
		STB-T-REM	Same fixings described above	--		
		STB-CH STB-T-CH	<u>Ref. 05.19.021</u> : L – shape profiles made of extruded raw finished sheets alloyed aluminium 6063 T5/T6, with perforations for fastening vertical and horizontal profiles with fixings described below). <u>Ref. 05.19.019 or 05.19.050: Reinforcing plate</u> : Aluminium alloy EN AW 1050 H22 (raw finished) fixed to each slot of vertical flanges on its backside with at least three rivets (extremes and centre): <u>Hanger ref. 05.019.013 for STB-CH</u> . Hanger ref. 05.19.062f or STB-T-CH: Alloyed aluminium EN AW 6063 T5/T6 extruded and raw finished profile plus PVC foam protective piece fixed to vertical profiles by self-screwing screws type DIN 7504 4,12x16 A2, i.e. SFS SN3/6-S-7049/SR2 or SFS SN3/9-S-7049/SR2 4,2x16	2-3-5 mm Thickness: 2 mm		
		STB-SZ	<u>Blind rivet 4,8 x 15</u> : Open end blind rivet , with A2 stainless steel break pull mandrel diameter d= 4,8 mm and length 15 mm, i.e. SFS Polygrip ASO-D-48140 Alu/inox A2	--		
		STB-T-SZ	<u>Blind rivet 4,8 x 15</u> : Same rivet described above (i.e. SFS Polygrip ASO-D-48140 Alu/inox A2) or optionally for fixing cassette to S/Z profiles <u>Self-screwing screw made of stainless steel A2 (DIN 7504 N)</u> for fixing cassette to S/Z profiles, specifically for fixing Z-profile to vertical profiles	-- --		
		Subframe fixing devices	Brackets: Elements used as load transmission between the subframe and the substrate wall.	STB REM STB-CH STB-SZ	<u>Ref. 05.19.004, 05.19.005, 05.19.006, 05.19.007</u> : TT-shape profiles made of extruded and mechanized alloyed aluminium EN AW 6063 T5/T6, raw finished sheet with perforation (and lateral tongues) for fastening vertical profiles (e.g. upper position) with fixings described below. <u>Ref. 05.19.030, 05.19.031, 05.19.032, 05.19.033, 05.19.034, 05.19.035, 05.19.036, 05.19.037, 05.19.038, 05.19.039</u> : TT-shape profiles made of extruded and mechanized alloyed aluminium EN AW 6005A T6, raw finished sheet with perforation (and lateral tongues) for fastening vertical profiles (e.g. upper position) with fixings described below. <u>Ref. 05.19.046, 05.19.047 U – shape profiles made of folded raw finished sheets alloyed aluminium 5005 H-24, with perforation (e.g. upper position) with fixings described below:</u>	Depth: 59-104 Height: 50 Width: 140 Thickness 3 Depth: 119-254 Height: 80 Width: 140 Thickness: 5 Depth: 59-89 Height: 80 Width: 52 Thickness 3
				STB-T-REM STB-T-SZ STB-T-CH	<u>Ref. 05.19.041, 05.19.042, 05.19.044, 05.19.045, 05.19.051, 05.19.052</u> : L – shape profiles made of bent raw finished sheets alloyed aluminium 5005 H-24, with perforation (and lateral tongues) for fastening vertical or horizontal profiles with fixings described below <u>05.19.053, 05.19.054, 05.19.055, 05.19.056</u> : L – shape profiles made of bent raw finished sheets alloyed aluminium 5005 H-24, with perforation (and lateral tongues) for fastening vertical or horizontal profiles with fixing as described below	Depth: 68-140 Height: 55/120 Width: 40 Thickness 3 Depth: 116-236 Height: 55 Width: 40-50 Thickness 5
				STB REM STB-CH STB-SZ	<u>For Omega shape vertical profile: Threaded bolt, washer and nut:</u> <u>Hexagon head screw ISO 4017 – M6x60/70 - 8.8</u> : Hexagon head screw (also known as DIN 931) class of thread A (metric 6 mm and 60/70 mm length) of galvanized steel 8.8. <u>Washer ISO 7089 -6 140 HV</u> : Flat washer (also known as DIN 125) class A of galvanized steel, nominal diameter 6 mm (int.) hardness 140 HV <u>Hexagonal nut ISO 4032 M6-8.8</u> : Hexagonal bolt (also known as DIN 934) type 1, of galvanized steel, thread 6 and quality class 8.8 Optionally: Self-drilling screw with hexagonal heads, washers and self-threading threads [Ø x L] 5.5 x 22 (ISO 15480) i.e. SFS SDA 5/3.5-h 13- S4-5.5x22 stainless steel 2 units (1 each side)	--
				STB-T-REM STB-T-SZ STB-T-CH	<u>For T-L shape vertical profile</u> : Self-drilling screw with hexagonal heads, washers, and self-threading threads [Ø x L] 5.5 x 22. (ISO 15480) i.e. SFS SDA 5/3.5-H 13--S4 5.5x22 stainless steel	--
Fixings between subframe elements	STB REM STB-CH STB-SZ		<u>For Omega shape vertical profile: Threaded bolt, washer and nut:</u> <u>Hexagon head screw ISO 4017 – M6x60/70 - 8.8</u> : Hexagon head screw (also known as DIN 931) class of thread A (metric 6 mm and 60/70 mm length) of galvanized steel 8.8. <u>Washer ISO 7089 -6 140 HV</u> : Flat washer (also known as DIN 125) class A of galvanized steel, nominal diameter 6 mm (int.) hardness 140 HV <u>Hexagonal nut ISO 4032 M6-8.8</u> : Hexagonal bolt (also known as DIN 934) type 1, of galvanized steel, thread 6 and quality class 8.8 Optionally: Self-drilling screw with hexagonal heads, washers and self-threading threads [Ø x L] 5.5 x 22 (ISO 15480) i.e. SFS SDA 5/3.5-h 13- S4-5.5x22 stainless steel 2 units (1 each side)	--		
	STB-T-REM STB-T-SZ STB-T-CH		<u>For T-L shape vertical profile</u> : Self-drilling screw with hexagonal heads, washers, and self-threading threads [Ø x L] 5.5 x 22. (ISO 15480) i.e. SFS SDA 5/3.5-H 13--S4 5.5x22 stainless steel	--		

(2) For further information see Table 15

2. Specification of the intended use in accordance with the applicable European Assessment Document (hereinafter EAD)

2.1 Intended use

The kits are intended to be used for ventilated external wall claddings which can be fixed to the external walls of new or existing buildings. The assessed kits are non-load-bearing construction systems, and therefore, they do not contribute to the stability of the wall on which are installed, neither to ensure the air tightness of the building structure. But they can contribute to durability of the works by providing enhanced protection from the effect of weathering.

2.2 Relevant general conditions for the use of the kits

The provisions made in this European Technical Assessment are based on an assumed working life of 25 years as minimum according to the EAD, provided that the conditions lay down for the installation, packaging, transport and storage as well as appropriate use, maintenance and repair are met. The indications given on the working life cannot be interpreted as a guarantee given by the producer, but are to be regarded only as a mean for choosing the right product in relation to the expected economically reasonable working life of the works.

2.3 Design of the kits in works

The design of external wall cladding for ventilated façade using the kits should consider:

- The mechanical characteristic values of the components (e.g. panels, cladding fixings and subframe) in order to resist the actions applying on the specific work.
- The substrate material to define the suitable anchorages.
- The possible movements of substrate and the position of the building expansion joints.
- The dilatation of components of the kits and of the panels.
- The category of corrosivity of the atmosphere of the works ⁽³⁾.
- Because joints are not watertight, the first layer behind ventilated air space must be composed by materials with low water absorption.
- The construction of singular parts of façade (e.g. base, top, corners, windows, etc).
- If the entire building must comply with the specific building regulations, particularly concerning fire and wind load resistance, of the Member States in which the work has been built.

2.4 Installation of the kits in works

Installation should be carried out according to the ETA holder's specifications and using the specific components of the kits, manufactured by the ETA holder or by suppliers recognized by the ETA holder. Installation should be carried out by appropriately qualified staff and under the supervision of the technical responsible of the site.

2.5 Use, maintenance and repair of the works

Maintenance of the assembled system or components of the kit includes inspections on site, taking into account the following aspects:

- Regarding the panels: Appearance of any damage such as cracking, delamination or detachment due to permanent and irreversible deformation.
- Regarding metallic components: Presence of corrosion or water accumulation.
- Necessary repairs should be done rapidly, using the same kit components and following the repair instructions given by ETA holder.

(3) e.g. See Table 1 of Standard EN ISO 12944-2:2017. Paints and varnishes. Corrosion protection of steel structures by protective paint systems. Part 2: Classification of environments.

3. Performance of the product and references to the methods used for its assessment

The assessment of the kits for ventilated external wall claddings according to the Basic Work Requirements (BWR) was carried out in compliance with the EAD 090062-00-0404. Characteristics of the components shall correspond to respective values laid down in the technical documentation of this ETA, checked by IETcc.

• Basic Work Requirement 2: Safety in case of fire

1 Reaction to fire:

Kits have been assessed ⁽⁴⁾ according to cl. 2.2.1 of EAD, as described below:

1.1 Kits STB–Rem / STB-T-Rem:

- Based on stacbond[®] PE: No performance assessed.
- Based on stacbond[®] FR: B-s1,d0. (Classification/Tests reports 3526T18 issued by AFITI, 2018).
- Based on stacbond[®] A2: A2-s1,d0. (Classification/Tests reports 3532T18 issued by AFITI, 2018).

1.2 Kits STB–CH / STB-T-CH:

- Based on stacbond[®] PE: No performance assessed.
- Based on stacbond[®] FR: B-s1, d0. (Classification/Tests reports 3526T18 issued by AFITI, 2018).
- Based on stacbond[®] A2: A2-s1,d0. (Classification/Tests reports 3532T18 issued by AFITI, 2018).

1.3 Kits STB – SZ / STB-T- SZ:

- Based on stacbond[®] PE: No performance assessed.
- Based on stacbond[®] FR: B-s1,d0. (Classification/Tests reports 3526T18 issued by AFITI, 2018).
- Based on stacbond[®] A2: A2-s1,d0 (Classification/Tests reports 3532T18 issued by AFITI, 2018).

These classifications are referred to Standard EN 13501-1 ⁽⁵⁾ and have been obtained from tests results carried out according to Standards EN ISO 1716 ⁽⁶⁾, EN ISO 11925-2 ⁽⁷⁾, EN 13823 ⁽⁸⁾.

In relation to the reaction to fire on rear side, it is considered above classifications as applicable.

2 Façade fire performance of kits clad with TMCP stacbond[®] PE/ stacbond[®] FR/ stacbond[®] A2:

No performance assessed.

3 Propensity to undergo continuous smouldering:

No performance assessed.

• Basic Work Requirement 3: Hygiene, health and the environment

4. Watertightness of joints (protection against driving rain):

Purposeless for claddings kits with open joints. Kits are not watertight according to cl. 2.2.4 of EAD.

5 Water absorption of cladding:

No performance assessed. Not relevant for ventilated façades according to cl. 2.2.5 of EAD.

(4) A European reference fire scenario has not been laid down for facades. In some Member States, the classification of the cladding kits according to Standard EN 13501-1 might not be sufficient for the use in façades. An additional assessment of the kits according to the national provision (e.g. on the basis of a large scale test) might be necessary to comply with Member State Regulations, until the existing European classification system has been completed.

(5) EN 13501-1:2007+A1:2010. Fire classification of construction products and building elements - Part 1: Classification using data from reaction to fire tests.

(6) EN ISO 1716:2001. Reaction to fire tests for products. Determination of the gross heat of combustion calorific value.

(7) EN ISO 11925-2:2011. Reaction to fire tests - Ignitability of products subjected to direct impingement of flame - Part 2: Single-flame source test.

(8) EN 13823:2012. Reaction to fire tests for building products - Building products excluding floorings exposed to the thermal attack by a single burning item.

6 Water permeability and water vapour permeability:

No performance assessed, as it is not relevant for ventilated façades according to cl. 2.2.6 of EAD.

7. Drainability:

According to cl. 2.2.7 of EAD, on the basis of the standard construction details the installation criteria of these kits and the technical knowledge and experience, it may be said the water which penetrates through joints into the air space or the condensation water can be drained out from the cladding without accumulation or moisture damage into the substrate.

8 Content, emission and/or release of dangerous substances:

No performance assessed.

• **Basic Work Requirement 4: Safety and accessibility in use**

9 Wind load resistance:

The kit behaviours exposed to wind pressure are most favourable than when exposed to wind suction. Therefore, wind pressure tests have been avoided and wind pressure resistance of kit can be considered as equal to wind suction resistance. Wind suction resistance of cladding kits has been determined by tests carried out according to cl. 2.2.9 of EAD, on several rigs most unfavourably but representative enough of the different cladding kits based on stacbond® PE, stacbond® FR and stacbond® A2 panels. Summaries of tests results are indicated in Tables at the following pages:

- STB–Rem (unidirectional substructure): Table 1.
- STB–Rem (bidirectional substructure): Table 2.
- STB-T-Rem (bidirectional substructure): Table 3.
- STB–CH (not reinforced slots): Table 4.
- STB–CH (reinforced slots): Table 5.
- STB-SZ / STB-T-SZ: Table 6.

Table 1: Summary of wind suction resistance results of STB REM cladding kit.						
Cladding kit composition		Test Results				
Rig	Non continuous boards riveted to a substructure composed of vertical profiles only	Load (Pa) ⁽⁹⁾	Type of failure ⁽¹⁰⁾	Deflection ⁽¹¹⁾ (mm)		
				Permanent d _p	Instantaneous d _i	
1	stacbond® FR 4 mm LxH=900x772 mm riveted on corners Maximum wind load resistance Q (Pa): 1200 - Perimeter rivets max. vertical distance: 734 mm - Perimeter rivets max. horizontal distance: 862 mm - Border rivets distance: 19 mm - Distance between vertical profiles: 920 mm - Distance between brackets: 995 mm	600	None	0.31	13.71	
		1200	None	0.94	24.10	
		1600	Reached max. admissible d _i	1.44	30.73	
		600	None	0.32	13.57	
	stacbond® PE 4 mm LxH=900x772 mm riveted on corners Maximum wind load resistance Q (Pa): 1200 - Perimeter rivets max. vertical distance: 734 mm - Perimeter rivets max. horizontal distance: 862 mm - Border rivets distance: 19 mm - Distance between vertical profiles: 920 mm - Distance between brackets: 938 mm	1200	None	0.88	23.31	
		1800	Reached max. admissible d _i	1.47	31.74	
		Continuous boards riveted to a substructure composed of vertical profiles only		Deflection⁽¹¹⁾ (mm)		
				Permanent d _p	Instantaneous d _i	
	stacbond® FR 4 mm LxH=1820x772 mm riveted on corners and middle of horizontal border Maximum wind load resistance Q (Pa): 1150 - Perimeter rivets max. vertical distance: 734 mm - Perimeter rivets max. horizontal distance: 920 mm - Border rivets distance: 19 mm - Distance between vertical profiles: 920 mm - Distance between brackets: 938 mm	600	None	0.42	11.72	
		1200	None	0.48	14.84	
		1800	None. End of test	1.90	25.50	
		stacbond® PE 4 mm LxH=1820x772 mm riveted on corners and middle of horizontal border		Maximum wind load resistance Q (Pa): 1150		
- Perimeter rivets max. vertical distance: 734 mm - Perimeter rivets max. horizontal distance: 920 mm - Border rivets distance: 19 mm - Distance between vertical profiles: 920 mm - Distance between brackets: 938 mm	600	None	0.16	12.58		
	1200	None	0.61	22.44		
	1800	None. End of test	1.38	31.40		

Table 2a: Summary of wind suction resistance results of STB REM cladding kit						
Cladding kit composition		Test Results				
Rig	Non continuous boards riveted to a bidirectional substructure	Load (Pa) ⁽⁹⁾	Type of failure ⁽¹⁰⁾	Deflection ⁽¹¹⁾ (mm)		
				Permanent d _p	Instantaneous d _i	
2	stacbond® FR 4 mm LxH=900x772 mm riveted on corners Maximum wind load resistance Q (Pa): 2200 - Perimeter rivets max. vertical distance: 734 mm - Perimeter rivets max. horizontal distance: 431 mm - Border rivets distance: 19 mm - Distance between vertical profiles: 920 mm - Distance between horizontal profiles: 792 mm - Distance between brackets: 938 mm	600	None	1.17	6.02	
		1200	None	1.44	11.86	
		1800	None	1.58	16.91	
		2200	None	2.19	20.32	
		3000	Significant permanent deflection d _p ≥ 3 mm	4.34	25.92	
		stacbond® PE 4 mm LxH=900x772 mm riveted on corners Maximum wind load resistance Q (Pa): 2200 - Perimeter rivets max. vertical distance: 734 mm - Perimeter rivets max. horizontal distance: 431 mm - Border rivets distance: 19 mm - Distance between vertical profiles: 920 mm - Distance between horizontal profiles: 792 mm - Distance between brackets: 938 mm	600	None	0.87	7.02
			1200	None	1.34	14.63
			1800	None	1.54	18.60
	2200		None	1.69	21.90	
	3000	None	2.03	28.01		
	3200	Significant permanent deflection d _p ≥ 3 mm Reached max. d _i	3.51	30.95		
	Continuous boards riveted to a bidirectional substructure		Deflection⁽¹¹⁾ (mm)			
			Load (Pa) ⁽⁹⁾	Type of failure ⁽¹⁰⁾	Permanent d _p	Instantaneous d _i
	stacbond® FR 4 mm LxH=1820x772 mm riveted on corners and middle of horizontal border Maximum wind load resistance Q (Pa): 2200 - Perimeter rivets max. vertical distance: 734 mm - Perimeter rivets max. horizontal distance: 460 mm - Border rivets distance: 19 mm - Distance between vertical profiles: 920 mm - Distance between horizontal profiles: 792 mm - Distance between brackets: 938 mm	600	None	0.87	7.66	
		1200	None	1.34	14.63	
		1800	None	1.63	20.50	
		2200	None	2.32	24.54	
	3000	Significant permanent deflection d _p ≥ 3 mm.	4.89	31.48		
	stacbond® PE 4 mm LxH=1820x772 mm riveted on corners and middle of horizontal border Maximum wind load resistance Q (Pa): 2200 - Perimeter rivets max. vertical distance: 734 mm - Perimeter rivets max. horizontal distance: 460 mm - Border rivets distance: 19 mm - Distance between vertical profiles: 920 mm - Distance between horizontal profiles: 792 mm - Distance between brackets: 938 mm	600	None	0.09	6.18	
		1200	None	0.32	12.29	
1800		None	0.53	17.42		
2200		None	0.66	20.88		
2800	Reached max. d _i	2.60	29.97			

(9) Maximum admissible load should be calculated taken into account other criteria if required (e.g. national regulations, ETA holder's program ABAKUS).

(10) The following types of failures are considered: Breakage of any cladding element, failure of fixing, failure of detachment of the frame, and significant permanent deflection. For this last one, it may be considered other than the declared by ETA-holder for ending the test (d_p ≥ 3 mm).

(11) Indicated accumulated deflection values measured at centre of front side of cladding (or distance between vertical profiles if continuously supported).

Table 2b: Summary of wind suction resistance results of STB REM cladding kit					
Cladding kit composition		Test Results			
Rig	Non continuous boards riveted to a bidirectional substructure	Load (Pa) ⁽⁹⁾	Type of failure ⁽¹⁰⁾	Deflection ⁽¹¹⁾ (mm)	
				Permanent d _p	Instantaneous d _i
M4-A2-1	stacbond® A2 4 mm LxH=900x1082 mm riveted on its perimeter Maximum wind load resistance Q (Pa): 1400 - Perimeter rivets max. vertical distance: 348 mm - Perimeter rivets max. horizontal distance: 431 mm - Border rivets distance: 19 mm - Distance between vertical profiles: 920 mm - Distance between horizontal profiles: 792 mm - Distance between brackets: 938 mm	600	None	0.03	7.48
		1200	None	0.39	13.47
		1400	None	0.64	15.22
		2400	Reached ~ maximum d _p . End of test	2.89	23.70

Table 3: Summary of wind suction resistance results of STB T-REM cladding kit.						
Cladding kit composition		Test Results				
Rig	Non continuous boards riveted to a bidirectional substructure	Load (Pa) ⁽⁹⁾	Type of failure ⁽¹⁰⁾	Deflection ⁽¹¹⁾ (mm)		
				Permanent d _p	Instantaneous d _i	
3	stacbond® FR 4 mm LxH=900x772 mm riveted on its perimeter Maximum wind load resistance Q (Pa): 2000 - Perimeter rivets max. vertical distance: 734 mm - Perimeter rivets max. horizontal distance: 862 mm - Border rivets distance: 19 mm - Distance between vertical profiles: 920 mm - Distance between brackets: 995 mm	600	None	0.02	7.13	
		1200	None	0.22	13.49	
		2000	None	1.18	19.16	
		3200	None	1.26	20.57	
	stacbond® PE 4 mm LxH=900x772 mm riveted on its perimeter Maximum wind load resistance Q (Pa): 2000 - Perimeter rivets max. vertical distance: 734 mm - Perimeter rivets max. horizontal distance: 862 mm - Border rivets distance: 19 mm - Distance between vertical profiles: 920 mm - Distance between brackets: 938 mm	600	None	0.07	6.57	
		1200	None	0.34	12.00	
		2000	None	0.94	16.26	
		3200	None. End of test	1.11	18.92	
		Continuous boards riveted to a bidirectional substructure	Load (Pa)⁽⁹⁾	Type of failure⁽¹⁰⁾	Deflection⁽¹¹⁾ (mm)	
					Permanent d_p	Instantaneous d_i
		stacbond® FR 4 mm LxH=1820x772 mm riveted on its perimeter Maximum wind load resistance Q (Pa): 1800 - Perimeter rivets max. vertical distance: 734 mm - Perimeter rivets max. horizontal distance: 920 mm - Border rivets distance: 19 mm - Distance between vertical profiles: 920 mm - Distance between brackets: 938 mm	600	None	0.24	6.61
			1200	None	0.74	12.85
			1800	None	0.90	16.18
			3200	None End of test	1.01	18.57
		stacbond® PE 4 mm LxH=1820x772 mm riveted on its perimeter Maximum wind load resistance Q (Pa): 1800 - Perimeter rivets max. vertical distance: 734 mm - Perimeter rivets max. horizontal distance: 920 mm - Border rivets distance: 19 mm - Distance between vertical profiles: 920 mm - Distance between brackets: 938 mm	600	None	0.06	6.57
			1200	None	0.34	12.06
1800			None	0.98	13.65	
3200			None End of test	1.51	19.59	

Cladding kit composition						Test Results			
Rig	Suspended cassettes with not reinforced slots	Load (Pa)⁽⁹⁾	Type of failure⁽¹⁰⁾	Deflection⁽¹¹⁾ (mm)					
				Permanent d_p	Instantaneous d_i				
4	stacbond® FR 4 mm based cassette LxH=900x2160 mm Maximum wind load resistance Q (Pa): 1150 - Simple folded vertical flanges 45 mm depth - Simple folded bottom flange - 5 not reinforced slots distanced 490 mm - Tongue width of slot: 15 mm	600	None	0.09	14.05				
		1200	None	0.33	23.79				
		1800	Reached max. admissible d _i = L/30	0.63	31.67				
		2000	None	0.87	34.73				
	stacbond® PE 4 mm based cassette LxH=900x2160 mm Maximum wind load resistance Q (Pa): 1150 - Simple folded vertical flanges 45 mm depth - Simple folded bottom flange - 5 not reinforced slots distanced 490 mm - Tongue width of slot: 15 mm	600	None	0.07	14.69				
		1200	None	0.36	24.85				
		1600	Reached max. admissible d _i = L/30	0.61	30.50				
		2000	Failure f1. Buckling of bottom flange	1.68	41.34				
M2-A2-1	stacbond® A2 4 mm based cassette LxH=900x2165 mm Maximum wind load resistance Q (Pa): 1150 - Simple folded vertical flanges 45 mm depth - Simple folded bottom flange - 5 not reinforced slots distanced 490 mm - Tongue width of slot: 15 mm	600	None	0.13	16.48				
		1000	None	0.34	23.88				
		1200	None	0.43	27.06				
		1400	Reached max. admissible d _i = L/30	0.53	30.06				
M4-A2-1	stacbond® A2 4 mm based cassette LxH=900x1082mm Maximum wind load resistance Q (Pa): 1400 - Simple folded vertical flanges 45 mm depth - Simple folded bottom flange: 45 mm - 5 not reinforced slots distanced 383 mm - Tongue width of slot: 15 mm	600	None	0.03	6.94				
		1000	None	0.19	10.43				
		1200	None	0.28	11.97				
		1400	None	0.37	13.36				
		2400	Breakage of lower left soft	--	--				
M3-A2-1	stacbond® A2 4 mm based cassette LxH=900x800mm Maximum wind load resistance Q (Pa): 2200 - Simple folded vertical flanges 45 mm depth - Simple folded bottom flange: 45 mm - 5 not reinforced slots distanced 155 mm - Tongue width of slot: 15 mm	1800	None	0.93	16.19				
		2000	None	1.17	17.64				
		2200	None	1.52	19.18				
		2400	None	3.40	23.57				
		2600	Reached max. admissible d _i = L/30	8.83	33.44				

Cladding kit composition						Test Results			
Rig	Suspended cassettes with reinforced slots	Load (Pa)⁽⁹⁾	Type of failure⁽¹⁰⁾	Deflection⁽¹¹⁾ (mm)					
				Permanent d_p	Instantaneous d_i				
5	stacbond® FR 4 mm based cassette LxH=900x2160 mm Maximum wind load resistance Q (Pa): 1150 - Simple folded vertical flanges 40 mm depth - Simple folded bottom flange - 5 reinforced slots distanced 490 mm - Tongue width of slot: 10.5 mm	600	None	0.27	14.76				
		1200	None	0.61	24.58				
		1600	Reached max. admissible d _i = L/30	0.83	30.10				
		2600	Failure f1. Broken central lower slot	--	50.38				
	stacbond® PE 4 mm based cassette LxH=900x2160 mm Maximum wind load resistance Q (Pa): 1150 - Simple folded vertical flanges 40 mm depth - Simple folded bottom flange - 5 reinforced slots distanced 490 mm - Tongue width of slot: 10.5 mm	600	None	0.21	14.40				
		1200	None	0.64	24.73				
		1600	Reached max. admissible d _i = L/30	0.87	30.46				
		2600	Failure f1 broken central lower slot	--	51.28				

Cladding kit composition						Test Results			
Rig	Fixed cassettes to S,Z profiles	Load (Pa)⁽⁹⁾	Type of failure⁽¹⁰⁾	Deflection⁽¹¹⁾ (mm)					
				Permanent d_p	Instantaneous d_i				
6	stacbond® FR 4 mm based cassette LxH=1820x575 mm Maximum wind load resistance Q (Pa): 1600 - Simple folded vertical flanges 30 mm depth - Simple folded bottom flange - Maximum admissible instantaneous deflection: 30 mm - Maximum admissible permanent deflection: 3 mm	600	None	0.08	3.31				
		1200	None	0.26	6.98				
		1600	None	0.32	9.52				
		3400	None	0.74	19.74				
	stacbond® PE 4 mm based cassette LxH=1820x575 mm Maximum wind load resistance Q (Pa): 1600 - Simple folded vertical flanges 30 mm depth - Simple folded bottom flange - Maximum admissible instantaneous deflection: 30 mm - Maximum admissible permanent deflection: 3 mm	600	None	0.04	3.64				
		1200	None	0.21	7.53				
		1600	None	0.26	10.29				
		3400	None	1.02	21.26				
M5-A2-1	stacbond® A2 4 mm based cassette LxH=1820x575 mm Maximum wind load resistance Q (Pa): 1600 - Simple folded vertical flanges 30 mm depth - Simple folded bottom flange - Maximum admissible instantaneous deflection: 30 mm - Maximum admissible permanent deflection: 3 mm	600	None	0.19	3.88				
		1200	None	0.37	7.93				
		1600	None	0.65	10.96				
		3400	None	1.15	17.02				

10 Resistance to horizontal point loads:

It has been assessed according to cl. 2.2.10 of EAD on the kits. Results are shown in Table 7.

PANEL TYPE	Deformation (mm)			Remarks
	Initial loaded 500 N	After 1 minute loaded 500 N	After 1 minute unloaded	
stacbond® PE	0.00	9.10	0.04	No reduction of performances
stacbond® FR	0.00	8.81	0.03	No reduction of performances
stacbond® A2	0.00	6.72	0.06	No reduction of performances

11 Impact resistance

It has been assessed according to cl. 2.2.11 of EAD on kits cladded with stacbond® PE, stacbond® FR and stacbond® A2. Results and use categories obtained are described below in Table 8. In any case, cladding product presented sharp or cutting edges or surfaces able to cause injury to occupants or people nearby.

Panel Type	Impact	Energy	Ball	Remarks
stacbond® PE stacbond® FR stacbond A2	hard body	1 J	0.5 kg	No deterioration (superficial damage without cracking)
		3 J	0.5 kg	No deterioration (superficial damage without cracking)
		10 J	1.0 kg	No deterioration (superficial damage without cracking)
stacbond® PE stacbond® FR stacbond A2	soft body	10 J	3.0 kg	No deterioration (superficial damage without cracking)
		60 J	3.0 kg	No deterioration (superficial damage without cracking)
		300 J	50 kg	No deterioration (significant permanent deflection without cracking)
		400 J	50 kg	No deterioration (significant permanent deflection without cracking)
Use category				(I) A zone readily accessible at ground level to the public and vulnerable to hard body impacts but not subjected to abnormally rough use.

Remark: Index of mechanical resistances

They have been assessed according to the respective parts of cl. 2.2.12 of EAD, on the relevant components of the applicable kit family when applicable, as indexed below, and developed in the following pages:

- Mechanical resistance of the cladding element:
 12. Bending strength of cladding element (TMCP): See Durability of this ETA.
 13. Resistance of the grooved cladding element (family C): Table 9.
 14. Resistance of the cladding element at dowel hole (family C): No performance assessed.
- Resistance of the connection between the cladding element and the cladding fixing:
 15. Pull through resistance (family A): Table 10.
 16. Pull through resistance under shear loads (family A): Table 11.
 17. Axial resistance: Not applicable for families A, C, G.
 18. Shear load resistance: Not applicable for families A, C, G.
 19. Combined tension and shear load resistance: Not applicable for families A, C, G.
 20. Resistance of slot (family G): Table 12.
- Mechanical resistance of cladding fixing:
 21. Resistance to vertical load (family C): No performance assessed.
 22. Pull-through resistance of fixings from profile (family C): Table 13.
 23. Resistance of metal clip: (family C): No performance assessed.
- Mechanical resistance of subframe components:
 24. Resistance of profiles: Table 14.
 25. Subframe fixings. Tension/pull out resistance: Table 15.
 26. Subframe fixings. Shear resistance: Table 15.
 27. Bracket resistance (horizontal and vertical loads): Tables 16 and 17

Table 9: Resistance of grooved cladding element. Kits STB-SZ, STB-T-SZ

Sample	Failure* load (kN)							Failure
	F ₁	F ₂	F ₃	F ₄	F ₅	F _m	F _{u,5}	
Profile S	1.16	1.22	1.09	1.15	1.16	1.16	1.05	Deformation of profile

* Key:

F₁₋₅=individual value.; F_m=mean value; F_{u,5}= characteristic value (75% confidence that 95% of the test results will be higher than this value).

Table 10: Pull-through resistance of cladding element. Kits STB-Rem, STB-T-Rem

Type of board	Supporting ring Ø (mm)	Fixing position	Failure load (N)							Type of failure
			F ₁	F ₂	F ₃	F ₄	F ₅	F _m	F _{u,5} *	
stacbond® PE	120	Centre	3220.5	2972.6	2838.9	3050.6	3179.9	3052.5	2690.6	5 fixings broken
		Lateral	2321.6	2202.7	2238.2	2171.1	2209.1	2228.5	2095.2	1 fixings broken (4 deformed boards)
		Corner	488.1	498.0	470.8	550.5	480.5	497.9	423.2	None (5 deformed boards)
	230	Centre	3168.8	3219.0	3177.2	3202.8	3194.9	3192.5	3145.8	5 fixings broken
		Lateral	1628.9	1429.1	1496.4	1448.8	1515.5	1503.7	1321.6	None (5 deformed boards)
		Corner	242.7	246.4	253.0	230.5	227.0	239.9	214.5	None (5 deformed boards)
	310	Centre	2560.2	2569.0	2601.3	2630.1	2838.4	2639.8	2373.2	3 fixings broken 2 fixings pulled
		Lateral	1840.9	1838.4	1928.0	1764.7	1782.7	1830.9	1682.2	2 fixings broken (3 deformed boards)
		Corner	193.5	193.6	183.00	183.60	190.90	188.92	176.7	None (5 deformed boards)
stacbond® FR	120	Centre	2620.3	2557.2	2494.6	2638.3	2732.7	2608.6	2400.0	5 fixings broken
		Lateral	1871.2	1908.0	1735.4	1636.7	1805.0	1791.2	1538.11	4 fixings broken (1 deformed boards)
		Corner	399.9	371.3	383.6	397.7	310.3	372.5	287.11	None (5 deformed boards)
	230	Centre	2682.4	2383.5	2643.6	2689.0	2783.4	2636.4	2285.9	5 fixings broken
		Lateral	1118.0	1012.5	1253.4	1172.2	1114.4	1134.1	928.6	None (5 deformed boards)
		Corner	140.8	177.3	190.2	177.2	168.7	170.8	127.8	None (5 deformed boards)
	310	Centre	2676.6	2641.0	2672.0	2713.8	2749.8	2690.6	2592.8	3 fixings broken 2 fixings pulled
		Lateral	1322.2	1507.3	1523.0	1333.8	1443.8	1426.0	1206.2	2 fixings broken (3 deformed boards)
		Corner	127.1	143.9	142.4	144.1	137.6	139.0	122.3	None (5 deformed boards)
stacbond® A2	120	Centre	2249.2	2142.0	2207.4	2154.5	2203.5	2191.3	2090.1	Puncturing
		Lateral	783.7	766.0	765.5	762.4	757.2	766.9	743.6	Puncturing
		Corner	233.1	236.4	229.0	228.6	233.8	232.2	224.4	Deformed boards
	230	Centre	2185.6	2368.1	2205.7	2160.3	2166.3	2217.2	2016.3	Puncturing
		Lateral	854.9	699.5	710.9	708.2	812.0	757.1	590.6	Puncturing
		Corner	152.2	154.9	119.0	158.3	131.8	148.5	109.6	Puncturing
	310	Centre	2233.1	2287.6	2227.4	2290.7	2216.6	2259.6	2190.8	Puncturing
		Lateral	696.0	653.4	656.5	663.4	675.6	669.0	628.5	Puncturing
		Corner	126.2	128.6	110.2	130.4	138.9	126.9	102.4	Puncturing

* Key:

F₁₋₅: Individual values. F_m: Mean value. F_{u,5}: Characteristic value (75% confidence that 95% of test results will be higher than this value)

Type of board		Failure* load (N)									Failure
		F ₁	F ₂	F ₃	F ₄	F ₅	F ₆	F ₇	F _m	F _{u,5}	
stacbond® PE	Border	2763.7	2784.5	2146.6	2269.1	2274.1	2672.4	2490.5	2485.9	1938.1	Teared panel
	Corner	2491.7	2392.0	2071.7	2438.6	2529.4	2748.7	2583.1	2465.0	2027.9	
stacbond® FR	Border	2588.1	2735.9	2649.8	2576.2	2623.7	2734.2	2818.0	2675.1	2486.8	
	Corner	2644.5	2595.2	2726.1	2602.2	2620.0	2522.3	2583.5	2613.4	2482.4	
stacbond® A2	Border	2577.0	2755.0	2850.0	2856.1	2666.0	--	--	2740.8	2460.6	
	Corner	3032.1	3015.5	3001.8	3122.5	2913.5	--	--	3017.0	2843.1	

* Key: F₁₋₆: individual value; F_m: mean value; F_{u,5}: characteristic value (75% confidence that 95% of the test results will be higher than this value).

Type of specimen	Failure load* (kN)								Failure
	F ₁	F ₂	F ₃	F ₄	F ₅	F ₆	F _m	F _{u,5}	
stacbond® PE reinforced slot (tongue 10.5 mm)	1.19	1.21	1.18	1.29	1.21	1.22	1.22	1.13	Deformation of reinforcement –slot and breakage of reinforced slot
stacbond® PE non reinforced slot (tongue 15 mm)	1.00	1.03	1.06	1.05	0.98	1.02	1.02	0.96	Deformation and breakage of slot
stacbond® FR reinforced slot (tongue 10.5 mm)	0.91	0.90	1.04	1.05	0.94	0.97	0.97	0.81	Deformation of reinforcement –slot and breakage of reinforced slot
stacbond® FR non reinforced slot (tongue 15 mm)	0.94	0.90	0.99	0.98	1.03	0.97	1.01	0.93	Deformation and breakage of slot
stacbond® A2 reinforced slot (tongue 10.5 mm)	1.10	1.03	1.05	1.05	1.00	1.04	1.05	0.97	Deformation of reinforcement –slot and breakage of reinforced slot
stacbond® A2 non reinforced slot (tongue 15 mm)	0.90	1.00	1.02	0.99	1.02	0.99	0.99	0.89	Deformation and breakage of slot

* Key: F₁₋₆: Individual value. F_m: Mean value. F_{u,5}: Characteristic value (75% confidence that 95% of test results will be higher than this value).

Sample	Failure* load (N)							Failure
	F ₁	F ₂	F ₃	F ₄	F ₅	F _m	F _{u,5}	
Screw +Profile Z	5701.7	4851.8	5170.4	6124.9	5307.4	5431.3	4281.8	Fixing pulled

* Key: F₁₋₅=individual value. F_m: mean value; F_{u,5}: characteristic value (75% confidence that 95% of the test results will be higher than this value).

Profile ref.	Type	Effective moment of Inertia (cm ⁴)		E modulus (MPa) (EN 1999 1-1)	Alloy EN AW	Mechanical characteristics (minimum)				
		I _x	I _y			R _m (MPa)	R _{p 0,2} (MPa)	A (%)	A _{50mm} (%)	HBW
05.19.003	Extruded Ω-shape Wing thickness ≥2 mm	6.03	15.35	70000	6063 T5	≥ 160	≥ 120	≥ 8	≥ 6	60
05.19.040	Extruded Ω-shape Wing thickness ≥2 mm	6.47	16.83							
05.19.043	Extruded T-shape Wing thickness ≥ 1,8 mm	9.66	7.46	70000	6063 T5	≥ 160	≥ 120	≥ 8	≥ 6	60
05.19.061	Extruded T Ω -shape Wing thickness ≥2 mm	8.12	8.62	70000	6063 T5	≥ 160	≥ 120	≥ 8	≥ 6	60

(12) EN 755-8:2009: Aluminium and aluminium alloys - Extruded rod/bar, tube and profiles - Part 2: Mechanical properties.

Table 15. Tension / pull out / shear resistance of subframe fixings

Kit (components)	Type of fixing (example)	Dimensions [d x L] mm	Mechanical properties (Source: Supplier Technical sheet)	
STB-REM STB-T-REM (Board to profiles)	<u>Standard exposure:</u> Blind rivet ⁽¹³⁾ 5.0 x 12 AiA/St (AlMg5) d _k =14 mm with A3 stainless steel break pull mandrel (SFS AP14-S-5,0x12) or optionally Self-screwing screw 4.8 x 19 stainless steel (SFS SLA3/6-D12-4,8 x19)	5.0 x 12 4.8 x 19	Blind rivet S AP14-S-5.0x12 - Pull out load F _Z (mean v.): 2250 N (thickness 1.8 mm) - Shear F _Q (mean v.): 2400 N (thickness 1.8 mm) - Tensile breaking load Z _b (mean v.): 3920 N - Shear breaking load Q _b (mean v.): 2550 N Screw SFS SLA3/6-D12-4.8x19 - Pull out load F _Z (mean v.): 2300 N (thickness 2 mm) - Shear F _Q (mean v.): 1638 N (thickness 2 mm) - Tensile breaking load Z _b (mean v.): 7850 N - Shear breaking load Q _b (mean v.): 5235 N	
	<u>Aggressive exposure (i.e. chlorides):</u> Blind rivet ⁽¹²⁾ 5.0 x 14 St/St.A4 d _k =15 mm (SFS SSO-D15-5,0x140-A4) or optionally Self-screwing screw 4.8 x 19 stainless steel (SFS SLA3/6-D12-4,8 x19)	5.0 x 14 4.8 x 19	Blind rivet SFS SSO-D15-5.0x140-A4 - Pull out load F _Z (mean v.): 2184 N (thickness 2 mm) - Shear F _Q (mean v.): 7544N (thickness 2mm) - Tensile breaking load Z _b (mean v.): 6586 N - Shear breaking load Q _b (mean v.): 6152 N Screw SFS SLA3/6-D12-4.8x19 - Pull out load F _Z (mean v.): 2300 N (thickness 2 mm) - Shear F _Q (mean v.): 1638 N (thickness 2 mm) - Tensile breaking load Z _b (mean v.): 7850 N - Shear breaking load Q _b (mean v.): 5235 N	
	Self-screwing screws ISO 15481 ⁽¹⁴⁾ (also known as DIN 7504 N) ⁽¹⁵⁾ ST 4.2 x 16 stainless steel A2 (SN3/6-S-7049/SR2 or SN3/9-S-7049/SR2)	4.2 x 16	- Tensile breaking load Z _b (mean v.): 5800 N - Shear breaking load Q _b (mean v.): 3700 N	
STB-CH Hanger ref. 05.019.013 and cassette to vertical profile Ω-shape ref.05.19.003 or 05.19.040 STB-SZ STB-T-SZ Horizontal profile ref.05.19.002 to vertical profile Ω-shape ref.05.19.003 or 05.19.040 or T vertical profile ref. 05.19.043 / 05.19.053 STB-T-REM Joining L profile ref.05.19.021 for T vertical and horizontal profile ref. 05.19.043/05.19.053	Blind rivets ⁽¹²⁾ 4,8x15 AiA/St (AlMg5) d _k =9.5 mm with A2 stainless steel break pull mandrel. (SFS intec Polygrip ASO-D-4.8x140) or optionally: Self-screwing screw 4.8x19 stainless steel (SFS SLA3/6-D12-4.8x19)	4.8 x 16 4.8 x 19	Blind rivet SFS intec Polygrip ASO-D-4.8x140 - Pull out load F _Z (mean v.): 590 N (thickness 0.5 mm) - Shear F _Q (mean v.): 1150 N (thickness 0.5 mm) - Tensile breaking load Z _b (mean v.): 2700 N - Shear breaking load Q _b (mean v.): 1800 N Screw SFS SLA3/6-D12-4.8x19 - Pull out load F _Z (mean v.): 2300 N (thickness 2 mm) - Shear F _Q (mean v.): 1638 N (thickness 2 mm) - Tensile breaking load Z _b (mean v.): 7850 N - Shear breaking load Q _b (mean v.): 5235 N	
STB-CH STB-SZ STB-REM (Bracket TT, U (ref. incl. Table 0b) to Ω profiles ref.05.19.003 / 05.19.040)	Through screw, washers and nut (Screw HISPANOX)	Class A hexagonal head screw EN ISO 4017 ⁽¹⁶⁾ 2 class C flat washers EN ISO 7092 ⁽¹⁸⁾ Hexagonal nut type 1 class A EN ISO 4032 ⁽¹⁹⁾	M 6x60 M 6x70 Ø nom: 6 bolt 6	Class ≥50 Tensile breaking resistance: ≥ 500 MPa (ISO 3506-1) ⁽¹⁷⁾ Hardness HV 140 Class ≥ 50 (ISO 3506-2) ⁽²⁰⁾
STB-T-REM STB-T-SZ STB-T-CH (Bracket L(ref. incl. Table 0b) to T vertical profile ref. 05.19.043 / 05.19.053	Self-drilling screw with hexagonal heads, washers, and self-threading threads [Ø x L] 5.5 x 22. (ISO 15480) i.e. SFS SDA 5/3.5-H 13--S4 5.5x22 stainless steel	5,5 x 22	SFS SDA 5/3.5-H 13--S4 5.5x22 - Pull out load F _Z (mean v.): 2433 N (thickness 2.0 mm) - Shear F _Q (mean v.): 4985 N (thickness 2.0 mm) - Tensile breaking load Z _b (mean v.): 11246 N - Shear breaking load Q _b (mean v.): 7698 N	

(13) Open end blind rivets not covered actually by EN standard

(14) EN ISO 15481:1999. Cross recessed pan head drilling screws with tapping screw head (ISO 15481.1999).

(15) DIN 7504 German national standard not valid

(16) EN ISO 4017:2014. Fasteners - Hexagon head screws - Product grades A and B (ISO 4017:2014)

(17) EN ISO 3506-1:2009. Mechanical properties of corrosion-resistant stainless steel fasteners - Part 1: Bolts, screws and studs (ISO 3506-1:2009)

(18) EN ISO 7092:2000. Plain washers. Small series. Product grade A. (ISO 7092:2000)

(19) EN ISO 4032:2012. Hexagon regular nuts (style 1) - Product grades A and B (ISO 4032:2012)

(20) EN ISO 3506-2:2009. Mechanical properties of corrosion-resistant stainless steel fasteners - Part 2: Nuts (ISO 3506-2:2009)

Table 16: Resistance to horizontal load (tension) of brackets			
BRACKETS (Depth of wing perpendicular to substrate)	Results		Remarks
	F_{1d} (daN) ΔL=1mm	F_s(daN) failure	
Ref. 05.19.004	215	No breakage. Purposeless	TT shape
Ref. 05.19.007	340	No breakage. Purposeless	TT shape. Result extended to ref. 05.19.005, ref. 05.19.006, and ref. 05.19.007
Ref. 05.19.034	1420	No breakage. Purposeless	TT shape. Result extended to ref. 05.19.030, ref. 05.19.031, ref. 05.19.032 and ref. 05.19.033
Ref. 05.19.039	1560	No breakage. Purposeless	TT shape. Result extended to ref. 05.19.035, ref. 05.19.036, ref. 05.19.037 and ref. 05.19.038
Ref: 05.19.041	230	No breakage. Purposeless	L shape
Ref:05.19.042	275	No breakage. Purposeless	L shape
Ref: 05.19.05.044	210	No breakage. Purposeless	L shape
Ref: 05.19.05.045	320	No breakage. Purposeless	L shape
Ref: 05.19.046	385	No breakage. Purposeless	U shape
Ref: 05.19.047	385	No breakage. Purposeless	U shape
Ref. 05.19.051	70	No breakage. Purposeless	Results of ref. 05.19.051 extended to ref.05.19.052 and ref.05.19.053
Ref. 05.19.054	231	No breakage. Purposeless	Results of ref. 05.19.054 extended to ref.05.19.055 and ref.05.19.056

Table 17: Resistance to vertical load (shear) of bracket				
BRACKETS (Depth of wing perpendicular to substrate)	Results			Remarks
	F_{1d} (daN) ΔL=1mm	F_{1d} (daN) ΔL=3mm	F_s(daN) failure	
Ref. 05.19.004	175	210	No breakage. Purposeless	TT shape
Ref. 05.19.007	86	100	No breakage. Purposeless	TT shape. Result extended to ref. 05.19.005, ref. 05.19.006, and ref. 05.19.007
Ref. 05.19.034	380	430	No breakage. Purposeless	TT shape. Result extended to ref. 05.19.030, ref. 05.19.031, ref. 05.19.032 and ref. 05.19.033
Ref. 05.19.039	235	265	No breakage. Purposeless	TT shape. Result extended to ref. 05.19.035, ref. 05.19.036, ref. 05.19.037 and ref. 05.19.038
Ref: 05.19.041	57	10	No breakage. Purposeless	L shape
Ref:05.19.042	119	140	No breakage. Purposeless	L shape
Ref: 05.19.05.044	40	10	No breakage. Purposeless	L shape
Ref: 05.19.05.045	82	95	No breakage. Purposeless	L shape
Ref: 05.19.046	114	124	No breakage. Purposeless	U shape
Ref: 05.19.047	52	59	No breakage. Purposeless	U shape
Ref. 05.19.051	8	4	No breakage. Purposeless	L-shape
Ref. 05.19.052	12	26	No breakage. Purposeless	L-shape
Ref. 05.19.053	27	57	No breakage. Purposeless	L-shape
Ref. 05.19.054	22	26	No breakage. Purposeless	L-shape
Ref. 05.19.055	16	24	No breakage. Purposeless	L-shape
Ref, 05.19.056	15	28	No breakage. Purposeless	L-shape

- **Basic Work Requirement 5: Protection against noise**

28 Airborne sound insulation
No performance assessed according to cl. 2.2.13 of EAD.

- **Basic Work Requirement 6: Energy economy and heat retention**

29 Thermal resistance
Not relevant as the cladding kit does not include the thermal insulation according to cl.2.2.14 of EAD.

- **Durability**

According to cl. 2.2.15 of EAD, which considers cl. 2.2.15.9 when cladding kits are based on TMCP, the assessment of durability is addressed to applicable characteristics 38 to 55 as described below:

- 30 Hygrothermal behaviour of the kit: Not relevant for the assessed kits
- 31 Behaviour after pulsating loads: See applicable characteristics from ∫.49 to ∫.50
- 32 Freeze-thaw resistance: See applicable characteristics from ∫.38 to ∫.55
33. Behaviour after immersion in water: See applicable characteristics from ∫.38 to ∫.55
34. Dimension stability: See applicable characteristics from ∫.38 to ∫.55
35. Chemical and biological resistance: Not relevant for the assessed kits
36. UV and radiation resistance: See applicable characteristics from ∫.38 to ∫.55
37. Corrosion. Resistance of substructure:

Table 18: Corrosion resistance of subframe components made of aluminium profiles				
Kit	Type	Alloy EN AW	Protection	Corrosion resistance (Eurocode 9) ⁽²¹⁾
Aluminium profiles	Vertical profiles	6063 T5/T6	Raw finished	Durability rating: B
	Bracket	6063 T5/T6 6005 A T6	Raw finished	Durability rating: B

According to ch. 4 Durability of Eurocode 9, under normal atmospheric conditions (e.g. rural, moderate industrial or urban areas), aluminium alloys profiles as listed above can be used without the need for surface protection to avoid loss of bearing capacity. In severe environments, especially those with a high chloride content, attention must be paid to the risk of galvanic corrosion. Some form of insulation between aluminium and more noble metals (e.g. carbon steel, stainless steel, copper) is recommended.

38. Decay of delamination resistance after hygrothermal cycles:

Table 19: Decay of resistance				
Sample	Characteristic	Mean value after ageing		Remarks
stacbond® PE stacbond® FR stacbond® A2	Delamination resistance	Front sheet: > 75% Initial value	Rear sheet > 75% Initial value	No cracks, or breakage

39. Decay of delamination resistance after immersion in boiling water 6 h at 90° C:

Table 20: Decay of resistance				
Sample	Characteristic	Mean value after ageing		Remarks
stacbond® PE stacbond® FR stacbond® A2	Delamination resistance	Front sheet: > 75% Initial value	Rear sheet > 75% Initial value	No cracks, or breakage

(21) (Eurocode 9): EN 1999-1-1:2007+A1:2009 Design of aluminium structures. General structural rules. Annex C. Table.C.1. and Table 3.1

40. Decay of delamination resistance after immersion in water 500 h at 20° C:

Table 21: Decay of resistance				
Sample	Characteristic	Mean value after ageing		Remarks
stacbond® PE stacbond® FR	Delamination resistance	Front sheet: > 75% Initial value	Rear sheet > 75% Initial value	No cracks, or breakage
stacbond® A2	Delamination resistance	Front sheet: < 75% Initial value	Rear sheet < 75% Initial value	--

41. Decay of delamination resistance after freeze-thaw cycles:

Table 22: Decay of resistance				
Sample	Characteristic	Mean value after ageing		Remarks
stacbond® PE stacbond® FR	Delamination resistance	Front sheet: > 75% Initial value	Rear sheet > 75% Initial value	No cracks, or breakage
stacbond® A2	Delamination resistance	Front sheet: < 75% Initial value	Rear sheet < 75% Initial value	--

42. Decay of delamination resistance after long term exposure to heat (2500 h at hot dry air 80 °C):

Table 23: Decay of resistance				
Sample	Characteristic	Mean value after ageing		Remarks
stacbond® PE stacbond® FR stacbond® A2	Delamination resistance	Front sheet: > 75% Initial value	Rear sheet > 75% Initial value	No cracks, or breakage

43. Decay of flexural resistance after hygrothermal cycles*:

Table 24: Decay of resistance				
Sample	Characteristic	Mean value after ageing		Remarks
stacbond® PE	Flexural resistance	> 75% Initial value	> 75% Initial value	No cracks, or breakage

44. Decay of flexural resistance after immersion in boiling water 6 h at 90° C*:

Table 25: Decay of resistance				
Sample	Characteristic	Mean value after ageing		Remarks
stacbond® PE	Flexural resistance	> 75% Initial value	> 75% Initial value	No cracks, or breakage

45. Decay of flexural resistance after immersion in water 500 h at 20 °C*:

Table 26: Decay of resistance				
Sample	Characteristic	Mean value after ageing		Remarks
stacbond® PE	Flexural resistance	> 75% Initial value	> 75% Initial value	No cracks, or breakage

46. Decay of flexural resistance after freeze-thaw cycles*:

Table 27: Decay of resistance				
Sample	Characteristic	Mean value after ageing		Remarks
stacbond® PE	Flexural resistance	> 75% Initial value	> 75% Initial value	No cracks, or breakage

47. Decay of flexural resistance after long term exposure to heat (2500 h at hot dry air 80 °C)*:

Table 28: Decay of resistance				
Sample	Characteristic	Mean value after ageing		Remarks
stacbond® PE	Flexural resistance	> 75% Initial value	> 75% Initial value	No cracks, or breakage

* Characteristics not applicable to panel stacbond® FR and stacbond® A2

48. Decay of flexural stiffness:

Table 29: Decay of flexural stiffness			
Sample	Characteristic	$d_{80 ME}$ (1 h 80°C)	Remarks
stacbond® PE stacbond® FR stacbond® A2	Increase of deflection after 1 h 80 °C	$\leq 1,25 d_{20 ME}$	No cracks, or breakage

49. Decay of resistance to routed and returned edge after TPB test flexural, pulsating loads:

Table 30: Decay of resistance to pull out pulsating loads			
Characteristic	PANEL TYPE	Load (N)	Remarks
		Aged characteristic force $F_{u,5}$	
TPB test Flexural pull out pulsating loads	stacbond® PE stacbond® FR stacbond® A2	$> 75\%$ Initial value	No cracks, breakage or delamination

50. Decay of resistance to slot and its fixing devices after pulsating loads:

Table 31: Decay of resistance to pull out pulsating loads			
Characteristic	PANEL TYPE	Load (N)	Remarks
		Aged characteristic force $F_{u,5}$	
Reinforced /Non reinforced slot	stacbond® PE stacbond® FR stacbond® A2	$> 75\%$ Initial value	No cracks, breakage or delamination

51. Corrosion infiltration after exposure to spray salt

Table 32: Corrosion resistance of cladding element made of coil coated aluminium		
Component		Corrosion infiltration
Cladding material	Material	
stacbond® PE stacbond® FR stacbond® A2	PVDF	No defects after 500 and 1000 h*

Key: Index 3 according to EN 1396: Aluminium and aluminium alloys. Coil coated sheet and strip for general applications. Specifications

52. Degree of blistering after exposure to humidity:

Table 33: Corrosion resistance of cladding element made of coil coated aluminium		
Component		Blistering
Cladding material	Material	
stacbond® PE stacbond® FR stacbond® A2	PVDF	No defects after 500 and 1000 h*

*Key: Index 3 according to EN 1396: Aluminium and aluminium alloys. Coil coated sheet and strip for general applications. Specifications

53. Retention of bright and colour:

Table 34: Retention of bright and colour					
Characteristic	Commercial ref.	Humidity	UVB & water 1500 h	Heat	Remarks
Retention of bright (gloss units)	Ultramarine Ral 9016 Silver metallic	Gloss _{AGED} ≥ 0.8 Gloss _{INI}	Gloss _{AGED} ≥ 0.8 Gloss _{INI}	Gloss _{AGED} ≥ 0.8 Gloss _{INI}	OK
Retention of colour ΔE	Ultramarine Ral 9016 Silver metallic	OK --	OK --	OK --	OK Not required

4. Assessment and verification of constancy of performance (hereinafter AVCP) system applied, with reference to its legal base

4.1 System of assessment and verification of constancy of performances

According to the decision 2003/640/EC of the European Commission ⁽²²⁾ the system of assessment and verification of constancy of performances (see Annex V to Regulation (EU) No 305/2011) given in the following Table applies:

Product(s)	Intended use(s)	Level(s) or class (es)	System (s)
Kits based on stacbond® PE	kits for external wall claddings	All / any	2+
Kits based on stacbond® FR / stacbond® A2	kits for external wall claddings	All / any	1

5. Technical details necessary for the implementation of the AVCP system, as provided for in the applicable EAD

The ETA is issued for the kits on the basis of agreed data / information which identify the products that have been assessed and judged. Detailed description and conditions of the manufacturing process of the kits, and all the relevant design and installation criteria of the kits are specified in the manufacturer's technical documentation deposited with the IETcc. It is the manufacturer's responsibility to make sure that all those who use the kits are appropriately informed of specific conditions according to sections 1, 2, 4 and 5 and including the annexes of this ETA.



Instituto de Ciencias de la Construcción Eduardo Torroja
CONSEJO SUPERIOR DE INVESTIGACIONES CIENTÍFICAS

c/ Serrano Galvache n. 4. 28033 Madrid.
Tel.: (+34) 91 302 04 40
<https://dit.ietcc.csic.es>



On behalf of the Instituto de Ciencias de la Construcción Eduardo Torroja
Madrid, 23th April 2021



Director

(22) Published in the Official Journal of the European Union (OJEU) L226/21 of 10.09.2003. See www.new.eur-lex.europa.eu/oj/direct-access.html

Annex A: General schemes

1:2 (A4)

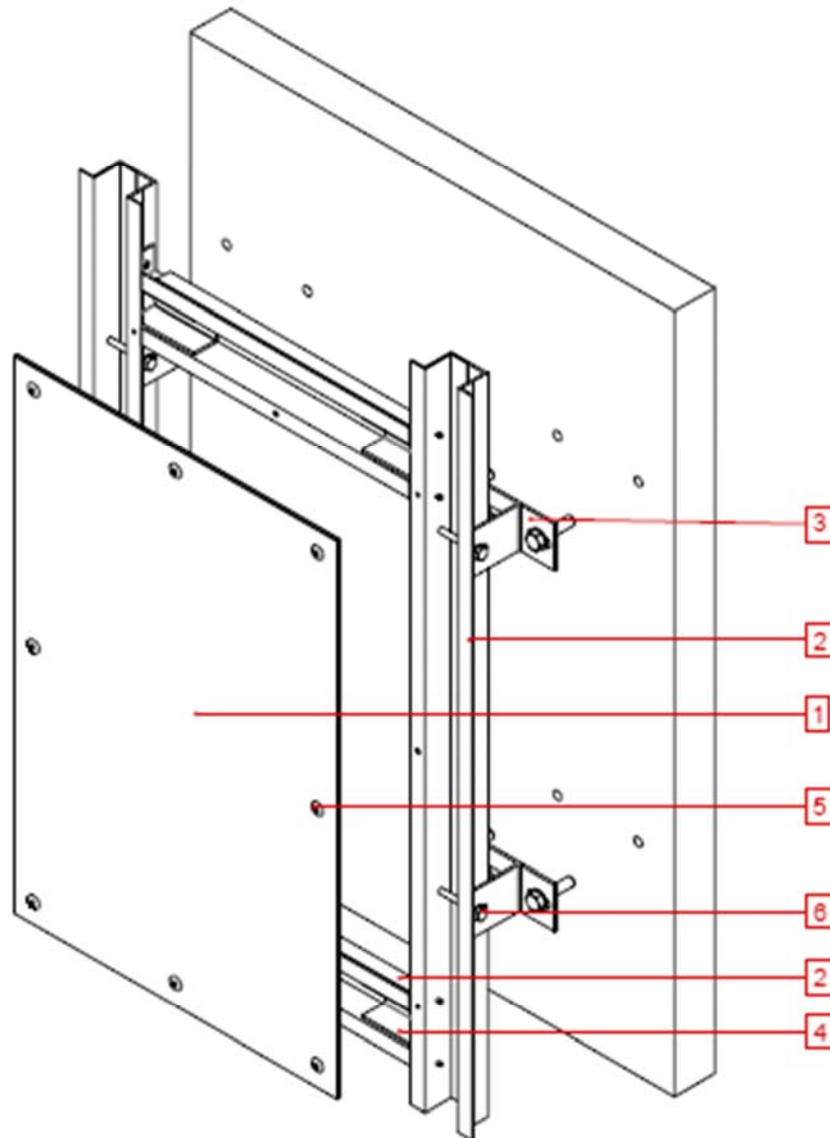

- 1 Board made of stacbond® PE / stacbond® FR / stacbond® A2
- 2 Omega Profile ref. 05.19.003
- 3 Double T Bracket i.e ref. 05.19.004
- 4 Studs joining STB-RIVETED ref. 05.19.020
- 5 Blind rivet 5.0 x 12 Al/inox (AlMg5) (dk=14 mm)
- 6 Hexagon head screw ISO 4017 – M6x60/70 - 8.8

Figure 1a. Example of STB – REM cladding kit (bidirectional substructure)

1:2 (A4)

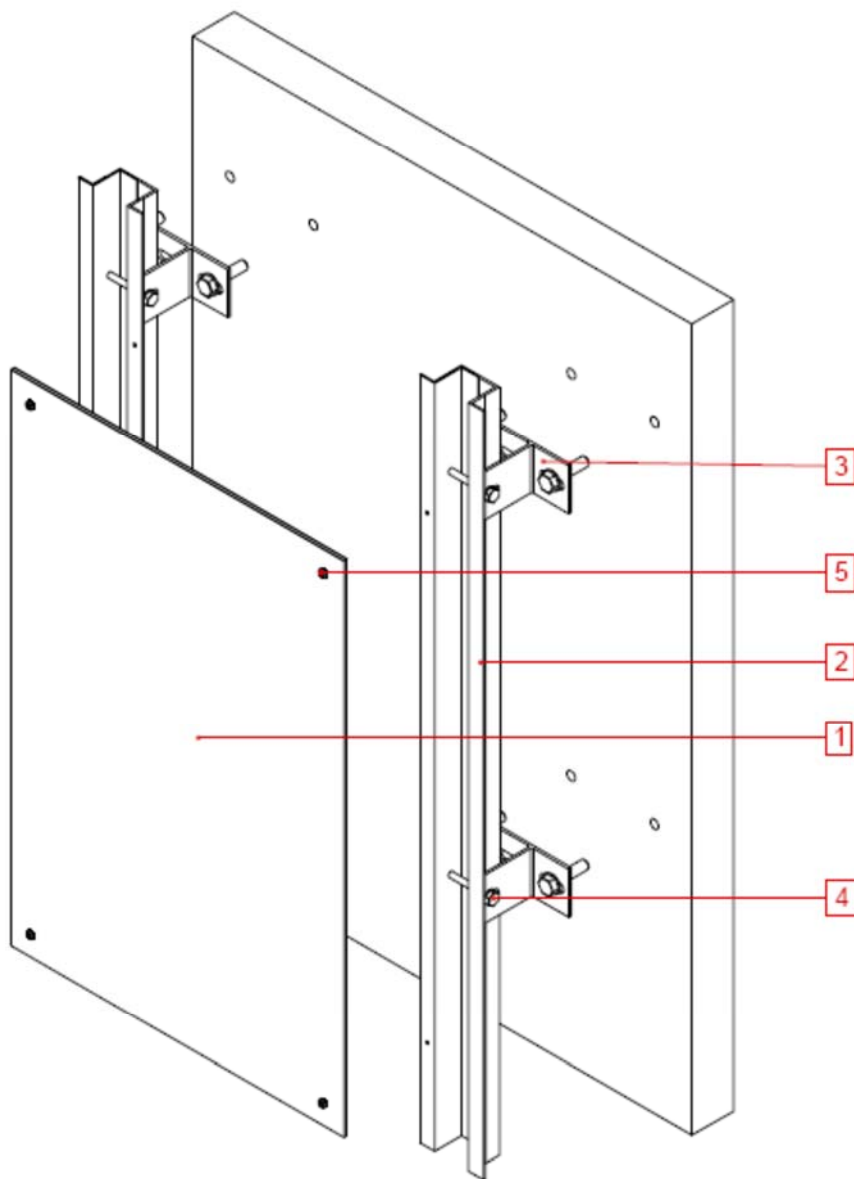

- 1 Board made of stacbond® PE / stacbond® FR / stacbond® A2
- 2 Omega Profile ref. 05.19.003
- 3 Double T Bracket i.e ref. 05.19.004
- 4 Hexagon head screw ISO 4017 – M6x60/70 - 8.8 / ALTERNATIVE 2 unit (1 each side) Self-drilling screw with hexagonal heads, 5.5x 22. stainless steel
- 5 Blind rivet 5.0 x 12 Al/inox (AlMg5) (dk=14 mm)

Figure 1b. Example of STB – REM cladding kit

1:2 (A4)

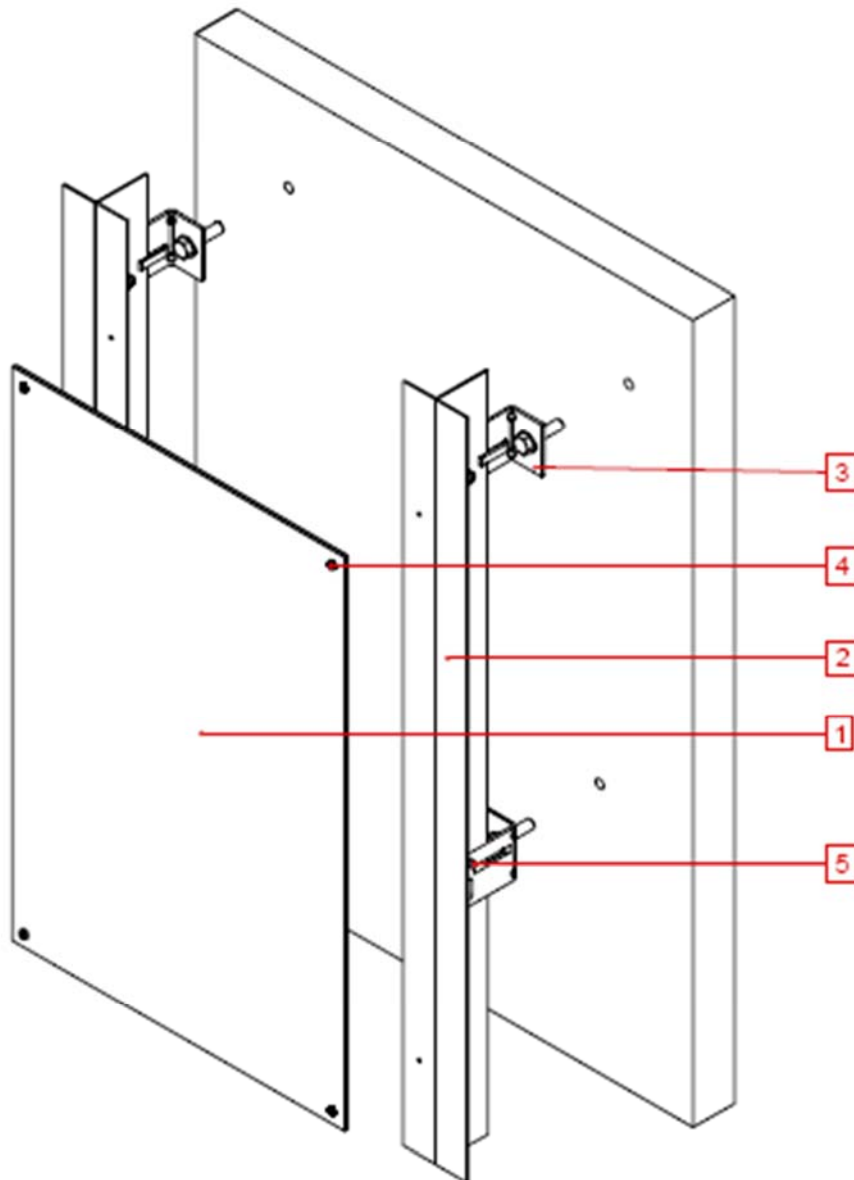

- 1 Board made of stacbond® PE / stacbond® FR / stacbond® A2
- 2 T profil ref. 05.19.043
- 3 L Bracket i.e ref. 05.19.041
- 4 Blind rivet 5.0 x 12 Al/inox (AlMg5) ($d_k=14$ mm)
- 5 Self-drilling screw with hexagonal heads, 5.5x 22. stainless steel

Figure 2. Example of STB –T- REM cladding kit

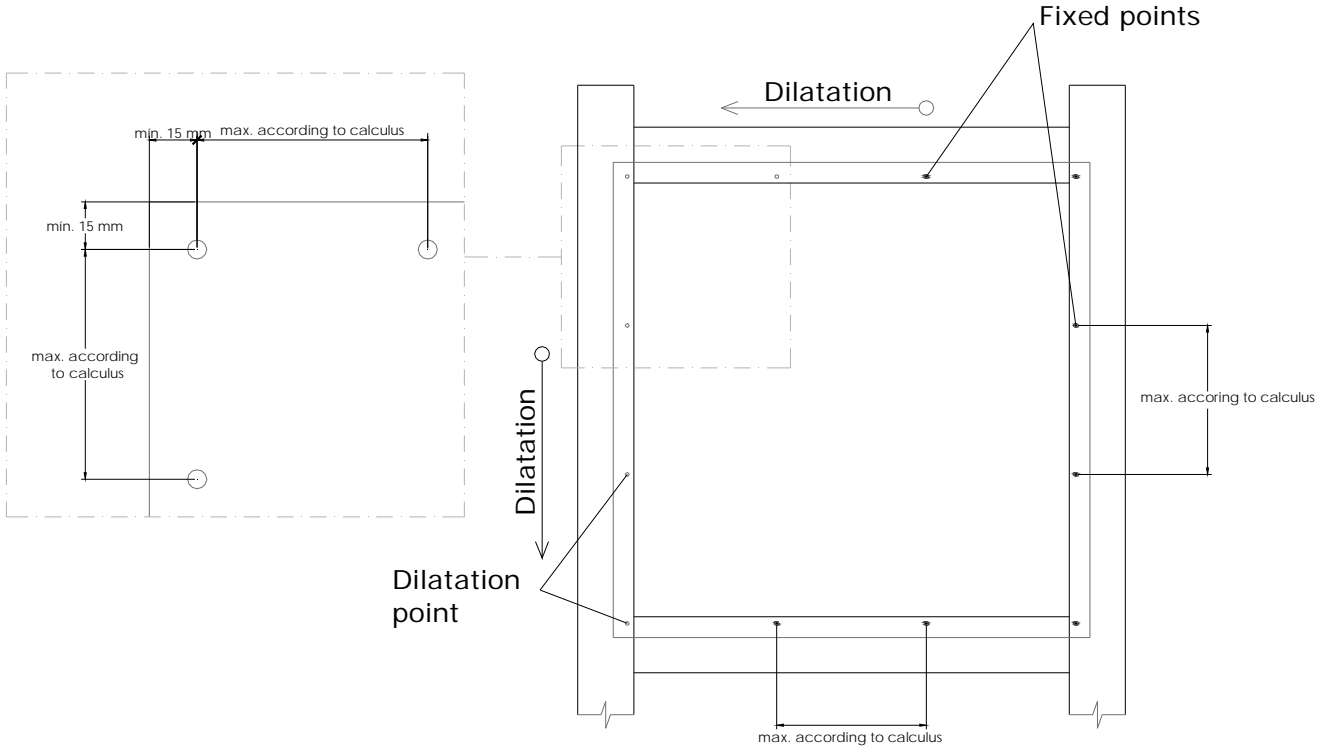
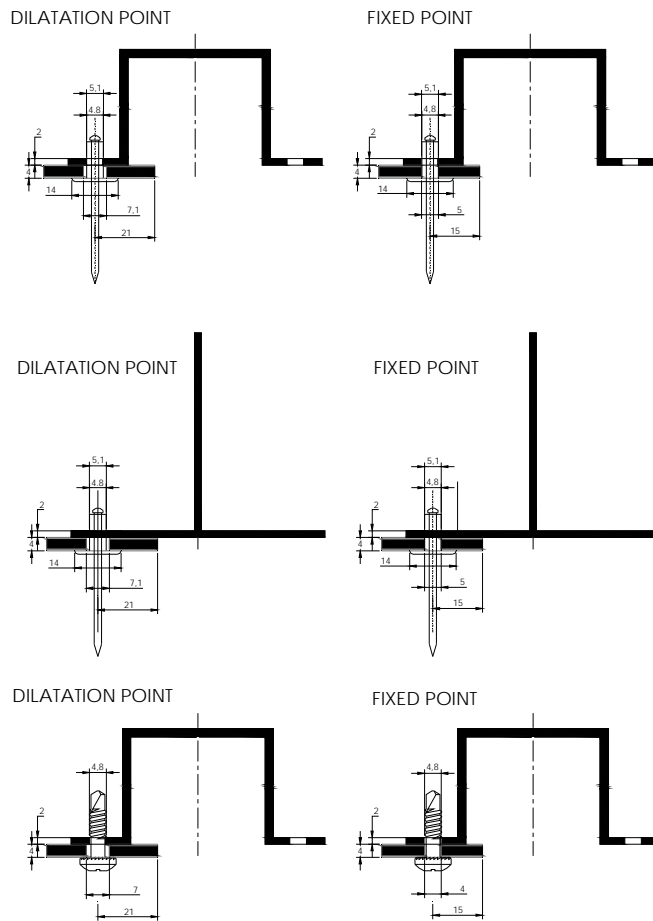
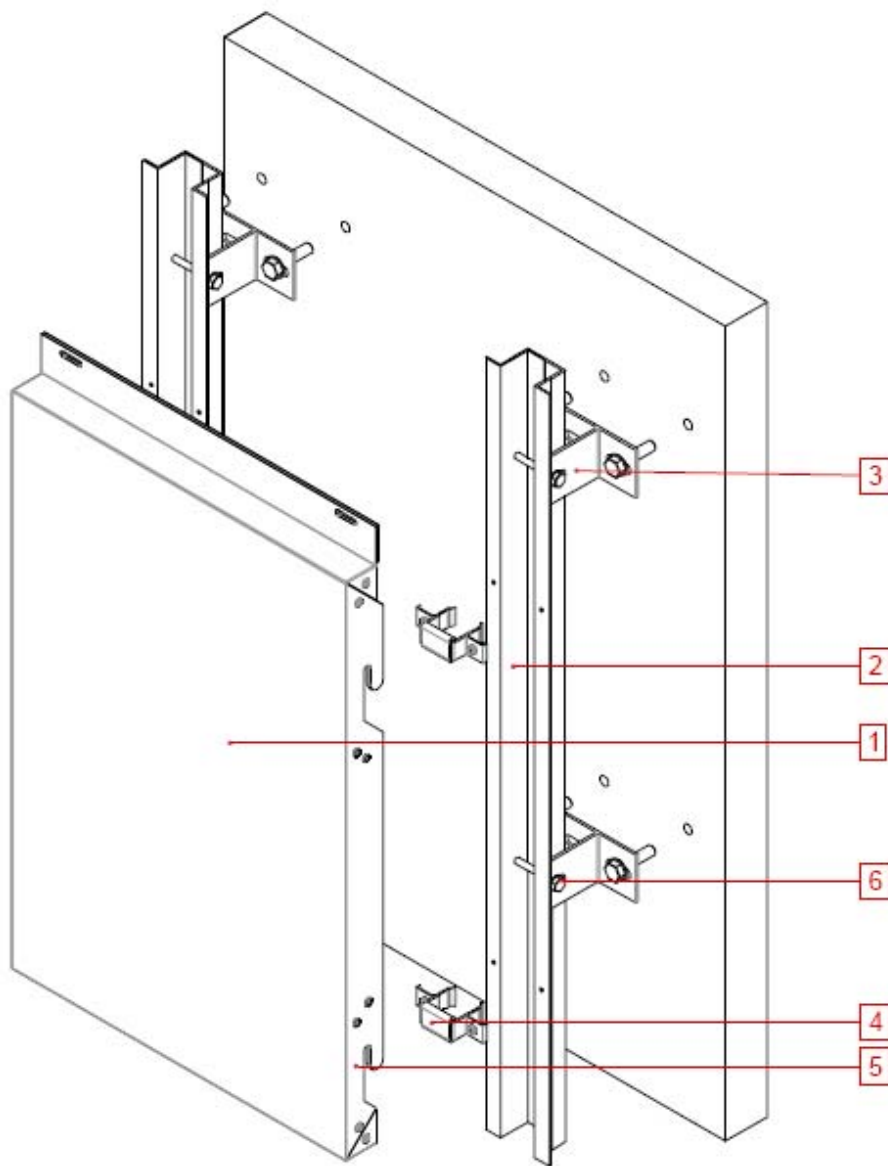

Figure 3. Details of STB – REM / STB –T- REM cladding kit



- 1 Cassette made of stacbond® PE / stacbond® FR / stacbond® A2
- 2 Omega Profile ref. 05.19.003
- 3 Double T Bracket i.e ref. 05.19.004
- 5 Hanging reinforcement ref. 05.19.019
- 4 External Hanging piece ref. 05.19.013
- 6 Hexagon head screw ISO 4017 – M6x60/70 - 8.8 / ALTERNATIVE 2 unit (1 each side)
Self-drilling screw with hexagonal heads, 5.5x 22 stainless steel

Figure 4a. Example of STB – CH cladding kit (cassette with reinforced slots)

05.19.012 PVC FOAM

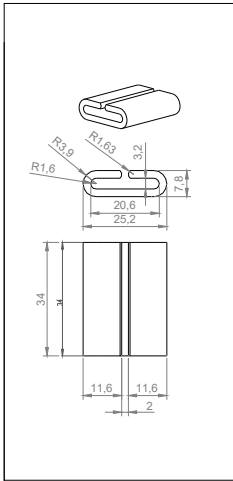

05.19.062 EXTERNAL HANGING PIECE STB-T-CH

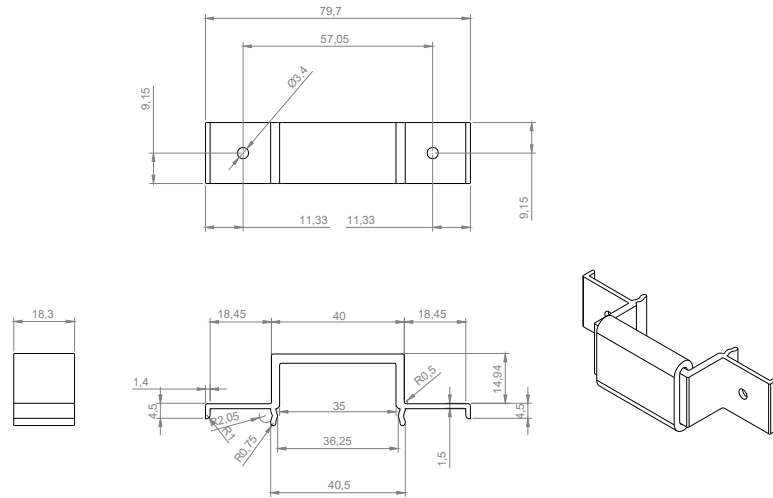

05.19.061 T-Omega PROFILE

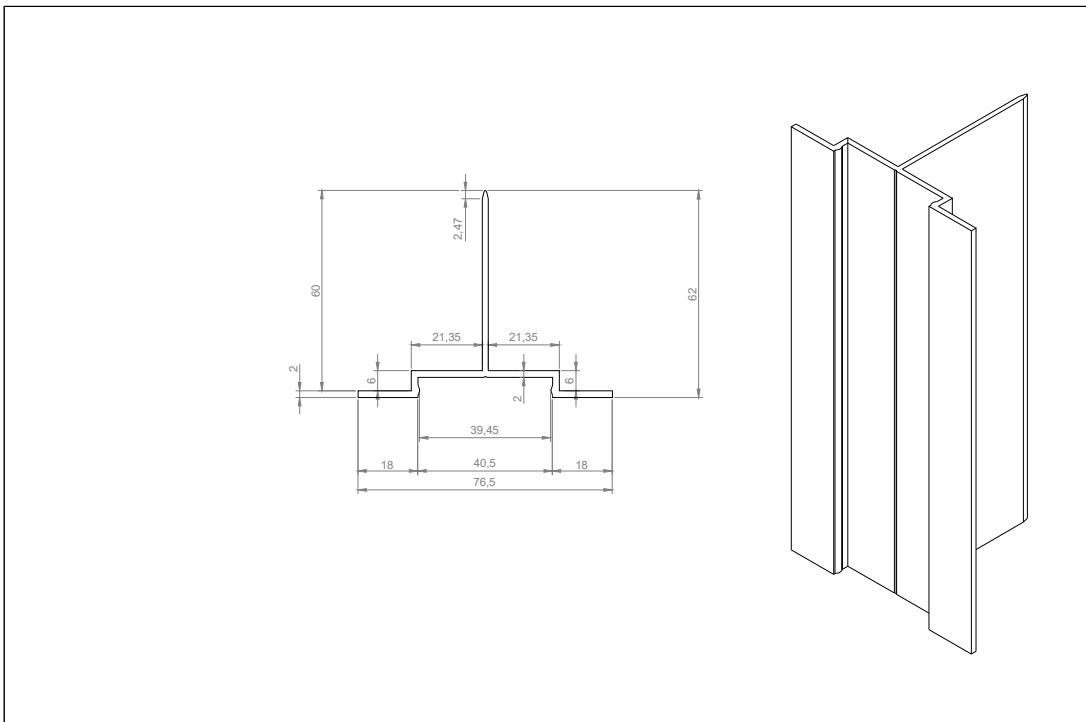
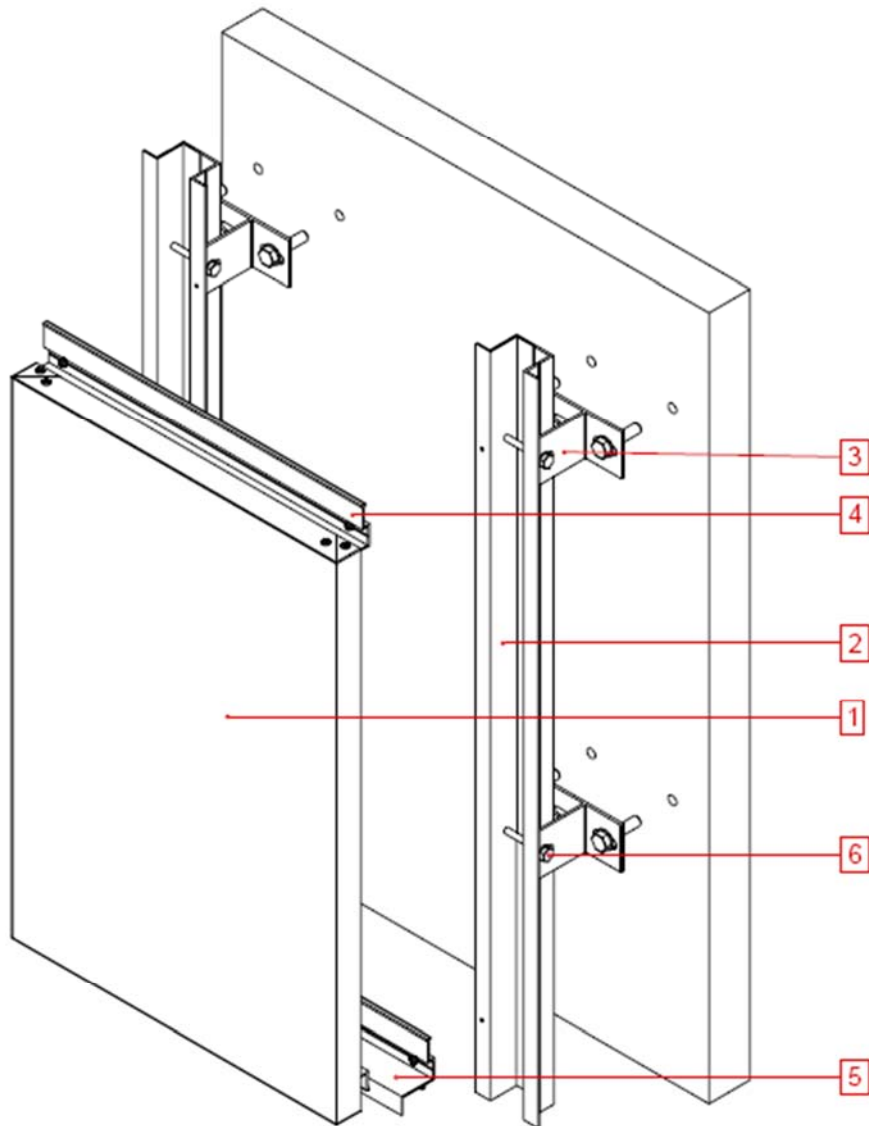

Figure 4b. Profiles for STB – T-CH cladding kit

1:2 (A4)



- 1 Cassette made of stacbond® PE / stacbond® FR / stacbond® A2
- 2 Omega Profile ref. 05.19.003
- 3 Double T Bracket i.e ref. 05.19.004
- 4 S profile ref. 05.19.001
- 5 Z profile ref. i.e 05.19.002
- 6 Hexagon head screw ISO 4017 – M6x60/70 - 8.8 / ALTERNATIVE: 2 unit (1 each side) Self-drilling screw with hexagonal heads, 5.5 x 22 stainless steel

Figure 5. Example of STB – SZ cladding kit

1:2 (A4)

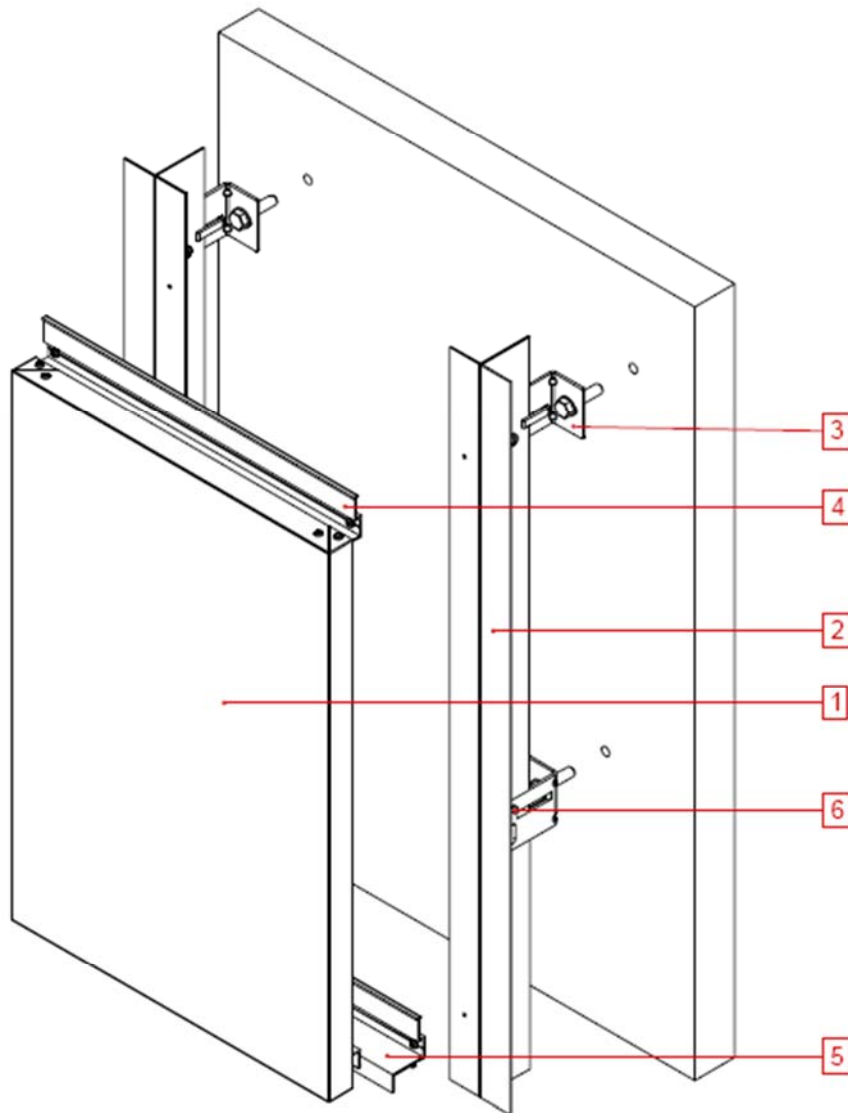

- 1 Cassette made of stacbond® PE / stacbond® FR / stacbond® A2
- 2 T profil ref. 05.19.043
- 3 L Bracket i.e ref. 05.19.041
- 4 S profile ref. 05.19.001
- 5 Z profile ref. i.e 05.19.002
- 6 Self-drilling screw with hexagonal heads, 5.5 x 22 stainless steel

Figure 6. Example of STB –T- SZ cladding kit

Annex B: Complementary physical and mechanical data of cladding kit elements

Panel	Material	Characteristics	Value
stacbond® PE stacbond® FR stacbond® A2	Removable protection film	Aspect:	White
	Coating layer (PVDF)	Thickness (µm)	From 22 to 33
	External sheet of alloyed aluminium EN AW 3005 H42/H44 or 3105 H42/H44/H46 or 5005 H42/H44 (painted)	E Modulus (MPa) Thickness (mm): Linear thermal expansion coefficient (K ⁻¹):	70 000 0.48 [± 0.02] 24 x 10 ⁻⁶
	Full core made of recycled low density polyethylene (stacbond® PE)	Aspect: Thickness (mm):	Black 3.0
	Core made mainly of mineral compounds, and recycled low density polyethylene (stacbond® FR)	Aspect: Thickness (mm):	Grey 3.0
	Full mineral core (stacbond® A2)	Aspect: Thickness (mm):	Granulated grey 3.0
	Rear sheet of alloyed aluminium EN AW 3005 H42/H44 or 3105 H42/H44/H46 or 5005 H42/H44 (painted)	E Modulus (MPa) Thickness (mm): Linear thermal expansion coefficient (K ⁻¹):	70 000 0.48 [± 0.02] 24 x 10 ⁻⁶
Coating layer (transparent)	Thickness (µm):	Confidential (Annex C)	

Panel	Material	Characteristic	Value	
stacbond® PE stacbond® FR stacbond® A2	Alloyed aluminium sheet EN AW 3005 H42	Tensile strength R _m (MPa)	≥ 140	
		Yield strength R _{p 0.2} (MPa)	≥ 95	
		Elongation A ₅₀ (%)	≥ 6	
	Alloyed aluminium sheet EN AW 3005 H44	Tensile strength R _m (MPa)	≥ 165	
		Yield strength R _{p 0.2} (MPa)	≥ 135	
		Elongation A ₅₀ (%)	≥ 3	
	Alloyed aluminium sheet EN AW 3105 H42	Tensile strength R _m (MPa)	≥ 130	
		Yield strength R _{p 0.2} (MPa)	≥ 105	
		Elongation A ₅₀ (%)	≥ 6	
	Alloyed aluminium sheet EN AW 3105 H44	Tensile strength R _m (MPa)	≥ 150	
		Yield strength R _{p 0.2} (MPa)	≥ 120	
		Elongation A ₅₀ (%)	≥ 3	
	Alloyed aluminium sheet EN AW 3105 H46	Tensile strength R _m (MPa)	≥ 175	
		Yield strength R _{p 0.2} (MPa)	≥ 150	
		Elongation A ₅₀ (%)	≥ 2	
	Alloyed aluminium sheet EN AW 5005 H42	Tensile strength R _m (MPa)	≥ 125	
		Yield strength R _{p 0.2} (MPa)	≥ 80	
		Elongation A ₅₀ (%)	≥ 4	
	Alloyed aluminium sheet EN AW 5005 H44	Tensile strength R _m (MPa)	≥ 145	
		Yield strength R _{p 0.2} (MPa)	≥ 110	
		Elongation A ₅₀ (%)	≥ 3	
	Peeling resistance between sheet (external or rear) and core (N.mm/mm) ASTM D 913			≥ 9.8

Annex C: Confidential information

This confidential information and is not included in the European Technical Assessment when that assessment is publicly available: C.1. Quality control of components of kits manufactured by suppliers or ETA holder.