

**INSTITUTO DE CIENCIAS
DE LA CONSTRUCCIÓN
EDUARDO TORROJA**

C/ Serrano Galvache n. 4 28033 Madrid (Spain)
Tel.: (34) 91 302 04 40 Fax: (34) 91 302 07 00
direccion.ietcc@csic.es <https://dit.ietcc.csic.es>

European Technical Assessment

**ETA 19/0703
of 31/10/2019**

English translation prepared by IETcc. Original version in Spanish language

General Part

**Technical Assessment Body issuing
the ETA designated according to Art.
29 of Regulation (EU) 305/2011:**

Instituto de Ciencias de la Construcción Eduardo Torroja (IETcc)

**Trade name of the construction
product:**

Hobson drop in anchor EDI / EDL

**Product family to which the
construction product belongs:**

Deformation controlled anchor made of galvanized steel of sizes M6, M8, M10, M12, M16 and M20 for multiple use for non-structural applications in concrete

Manufacturer:

Hobson Engineering Co. Pty. Ltd.
10 Clay Place, Eastern Creek,
NSW, Australia 2766
website: www.hobson.com.au

Manufacturing plants:

Hobson Engineering plant n. 1

**This European Technical
Assessment contains:**

9 pages including 3 annexes which form an integral part of this assessment.

**This European Technical
Assessment is issued in accordance
with regulation (EU) No 305/2011, on
the basis of:**

European Technical Assessment EAD 330747-00-0601 "Fasteners for use in concrete for redundant non-structural systems", ed. May 2018

English translation prepared by IETcc

This European Technical Assessment is issued by the Technical Assessment Body in its official language. Translations of this European Technical Assessment in other languages shall fully correspond to the original issued document and should be identified as such.

This European Technical Assessment may be withdrawn by the issuing Technical Assessment Body, in particular pursuant to information by the Commission according to article 25 (3) of Regulation (EU) No 305/2011.

SPECIFIC PART

1. Technical description of the product

The Index EDI / EDL in the range of M6 to M20 is an anchor made of galvanised steel, which is placed into a drilled hole and anchored by deformation-controlled expansion. The anchorage is characterised by friction between the sleeve and concrete.

Product and installation descriptions are given in annex A.

2. Specification of the intended use in accordance with the applicable European Assessment Document.

The performances given in section 3 are only valid if the anchor is used in compliance with the specifications and conditions given in annex B.

The verifications and assessment methods on which this European Technical Assessment is based, lead to the assumption of a working life of the anchor of at least 50 years. The indications given on the working life can not be interpreted as a guarantee given by the producer, but are to be regarded only as a mean to choosing the right products in relation to the expected economically reasonable working life of the works.

3. Performance of the product and references to the methods used for its assessment

3.1 Mechanical resistance and stability (BWR 1)

Essential characteristic	Performance
Characteristic resistance under static or quasi static loading	See annexes C1 and C2

3.2 Safety in case of fire (BWR 2)

Essential characteristic	Performance
Reaction to fire	Anchorage satisfy requirements for class A1
Resistance to fire	See annex C2

3.3 Hygiene, health and the environment (BWR 3)

This requirement is not relevant for the anchors.

3.4 Safety in use (BWR 4)

The essential characteristics regarding safety in use are included under the basic works requirements Mechanical resistance and stability.

3.5 Protection against noise (BWR 5)

This requirement is not relevant for the anchors.

English translation prepared by IETcc

3.6 Energy economy and heat retention (BWR 6)

This requirement is not relevant for the anchors.

3.7 Sustainable use of natural resources (BWR 7)

No performance determined

4. Assessment and Verification of Constancy of Performances (hereinafter AVCP) system applied, with reference to its legal base

The applicable European legal act for the system of Assessment and Verification of Constancy of Performances (see annex V to Regulation (EU) No 305/2011) is 97/161/EG.

The system to be applied is 2+.

5. Technical details necessary for the implementation of the AVCP system, as provided for in the applicable European Assessment Document.

The technical details necessary for the implementation of the AVCP system are laid down in the quality plan deposited at Instituto de Ciencias de la Construcción Eduardo Torroja.



Instituto de ciencias de la construcción Eduardo Torroja
CONSEJO SUPERIOR DE INVESTIGACIONES CIENTÍFICAS

C/ Serrano Galvache n.º 4. 28033 Madrid.
Tel: (+34) 91 302 04 40 Fax. (+34) 91 302 07 00
<https://dit.ietcc.csic.es>



On behalf of the Instituto de Ciencias de la Construcción Eduardo Torroja
Madrid, 31th of October 2019



Director

Product

EDI, EDL anchor



EDI anchor

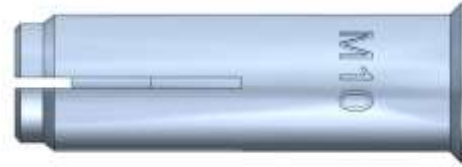

EDL anchor

Identification on sleeve: "EDI (EDL)" + Metric; e.g: EDI M6

Anchor dimensions	M6	M8	M10	M12	M16	M20
ØD: External diameter [mm]	8	10	12	15	20	25
Ød: internal diameter [mm]	M6	M8	M10	M12	M16	M20
L: total length [mm]	25	30	40	50	65	80

Setting tool



Setting tool dimensions	M6	M8	M10	M12	M16	M20
Ø D ₁ [mm]	7,5	9,5	11,5	14,5	18,0	22,0
Ø D ₂ [mm]	5,0	6,5	8,0	10,2	13,5	16,5
L _s [mm]	15	18	24	30	36	50

Setting tool could be assembled with a plastic handle for hand protection purposes

EDI, EDL anchor	Annex A1
Product description	
Product	

Installed condition

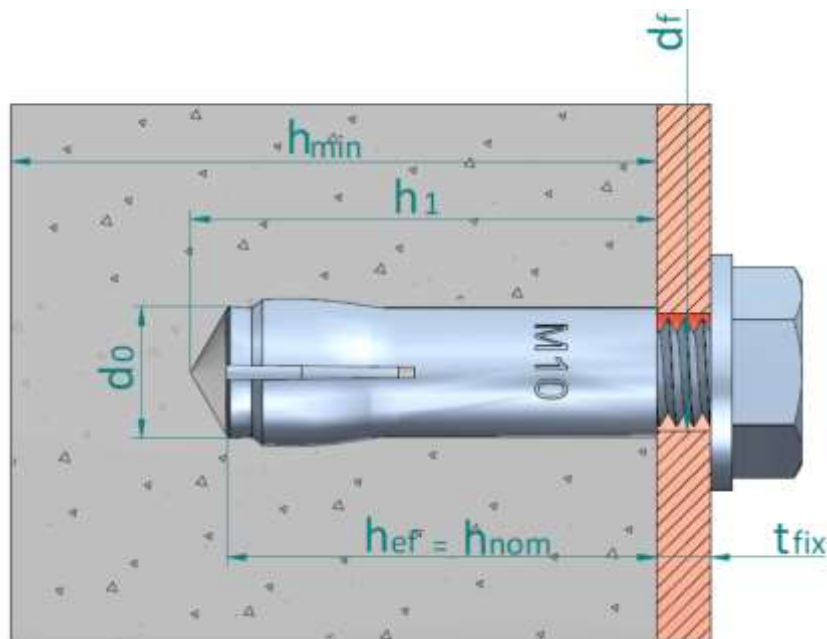

- h_{ef} : Effective anchorage depth
- h_1 : Depth of drilled hole
- h_{nom} : Overall anchor embedment depth in the concrete
- h_{min} : Minimum thickness of concrete member
- t_{fix} : Thickness of fixture
- d_0 : Nominal diameter of drill bit
- d_f : Fixture clearance hole diameter

Table A1: Materials

Item	Designation	Material for EDI / EDL
1	Sleeve	Carbon steel wire rod, zinc plated $\geq 5 \mu\text{m}$ ISO 4042 A2
2	Cone	Carbon steel wire rod, zinc plated $\geq 5 \mu\text{m}$ ISO 4042 A2
3	Plastic retainer	PVC

EDI, EDL anchor

Product description

Installed condition and Materials

Annex A2

Specifications of intended use

Anchorage subjected to:

- Static or quasi static loads for multiple use in non-structural applications
- Fire exposure
- The anchor may only be used if in the design and installation specifications for the fixture the excessive slip or failure of one anchor will not result in a significant violation of the requirements on the fixture in the serviceability and ultimate state.

Base materials:

- Reinforced or unreinforced normal weight concrete according to EN 206-1:2008
- Strength classes C12/15 to C50/60 according to EN 206-1:2008
- Cracked or uncracked concrete

Use conditions (environmental conditions):

- Anchorages subjected to dry internal conditions.

Design:

- Anchorages are designed under the responsibility of an engineer experienced in anchorages and concrete.
- Verifiable calculation rules and drawings are prepared taking into account of the loads to be anchored. The position of the anchor is indicated on the design drawings (e.g. position of the anchor relative to reinforcement or to supports, etc.).
- Anchorages under static or quasi-static actions are designed for design method B in accordance with:
 - EN 1992-4:2018
- Anchorages under fire exposure are designed in accordance to:
 - EN 1992-4:2018
 - It must be ensured that local spalling of the concrete cover does not occur.

Installation:

- Hole drilling by rotary plus hammer mode.
- Anchor installation carried out by appropriately qualified personal and under the supervision of the person responsible for technical matters of the site.
- In case of aborted hole: new drilling at a minimum distance away of twice the depth of aborted hole or smaller distance if the aborted hole is filled with high strength mortar and if under shear or oblique tension load it is not the direction of the load application.
- The bolt or threaded rod to be used shall be property class 4.6 / 5.6 / 5.8 / 6.8 or 8.8 according to ISO 898-1.
- The length of the bolt shall be determined as:
 - Minimum bolt length = $t_{fix} + l_{s,min}$
 - Maximum bolt length = $t_{fix} + l_{s,max}$

EDI, EDL anchor	Annex B1
Intended use	
Specifications	

Table C1: Installation parameters for EDI, EDL anchor

Installation parameters			Performances					
			M6	M8	M10	M12	M16	M20
d_o	Nominal diameter of drill bit:	[mm]	8	10	12	15	20	25
D	Thread diameter:	[mm]	M6	M8	M10	M12	M16	M20
d_f	Fixture clearance hole diameter \leq	[mm]	7	9	12	14	18	22
T_{inst}	Maximum installation torque:	[Nm]	4	11	17	38	60	100
$l_{s,min}$	Minimum screwing depth:	[mm]	6	8	10	12	16	20
$l_{s,max}$	Maximum screwing depth:	[mm]	10	13	17	21	27	34
h_{min}	Minimum thickness of concrete member:	[mm]	100	100	100	100	130	160
h_1	Depth of drilled hole:	[mm]	27	33	43	54	70	86
h_{nom}	Overall anchor embedm. depth in the concrete:	[mm]	25	30	40	50	65	80
h_{ef}	Effective anchorage depth:	[mm]	25	30	40	50	65	80
s_{min}	Minimum allowable spacing:	[mm]	60	60	80	100	130	160
c_{min}	Minimum allowable distance:	[mm]	105	105	140	175	230	280

Installation process

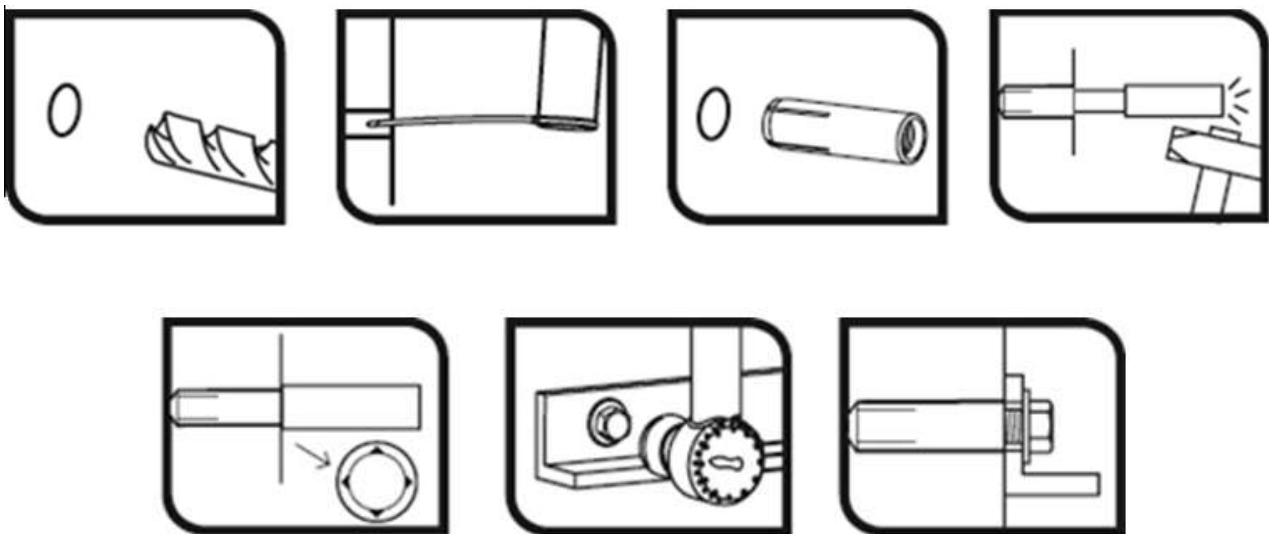

EDI, EDL anchor

Performances

Installation parameters and installation procedure

Annex C1

English translation prepared by IETcc

Table C2: Characteristic values to loads of design method B according to EN 1992-4 for EDI, EDL anchor

Characteristic values of resistance to loads of design method B			Performances					
			M6	M8	M10	M12	M16	M20
All load directions								
F_{Rk}^0	Characteristic resistance in C12/15 concrete:	[kN]	1,5	3,0	4,0	6,0	9,0	16,0
F_{Rk}^0	Characteristic resistance in C20/25 to C50/60 concrete:	[kN]	2,0	3,0	5,0	7,5	12,0	20,0
γ_{ins}	Installation safety factor:	[-]	1,2	1,2	1,4	1,4	1,4	1,4
S_{cr}	Characteristic spacing:	[mm]	75	90	120	150	195	240
C_{cr}	Characteristic edge distance:	[mm]	40	45	60	75	100	120
Shear loads: steel failure with lever arm								
$M_{Rk,s}^0$	Characteristic bending moment, steel class 4.6	[Nm]	6,1	15,0	29,9	52,4	133,3	259,8
γ_{Ms}	Partial safety factor:	[-]	1,67	1,67	1,67	1,67	1,67	1,67
$M_{Rk,s}^0$	Characteristic bending moment, steel class 4.8	[Nm]	6,1	15,0	29,9	52,4	133,3	259,8
γ_{Ms}	Partial safety factor:	[-]	1,25	1,25	1,25	1,25	1,25	1,25
$M_{Rk,s}^0$	Characteristic bending moment, steel class 5.6	[Nm]	7,6	18,8	37,4	65,5	166,6	324,8
γ_{Ms}	Partial safety factor:	[-]	1,67	1,67	1,67	1,67	1,67	1,67
$M_{Rk,s}^0$	Characteristic bending moment, steel class 5.8	[Nm]	7,6	18,8	37,4	65,5	166,6	324,8
γ_{Ms}	Partial safety factor:	[-]	1,25	1,25	1,25	1,25	1,25	1,25
$M_{Rk,s}^0$	Characteristic bending moment, steel class 6.8	[Nm]	9,2	22,5	44,9	78,7	199,9	389,7
γ_{Ms}	Partial safety factor:	[-]	1,25	1,25	1,25	1,25	1,25	1,25
$M_{Rk,s}^0$	Characteristic bending moment, steel class 8.8	[Nm]	12,2	30,0	59,9	104,9	266,6	519,7
γ_{Ms}	Partial safety factor:	[-]	1,25	1,25	1,25	1,25	1,25	1,25

1

Table C3: Characteristic resistance under fire exposure in concrete C20/25 to C50/50 in any load direction according to EN 1992-4 for EDI, EDL anchor

Characteristic resistance under fire exposure in concrete C20/25 to C50/60 in any load direction for use in concrete			Performances					
			M6	M8	M10	M12	M16	M20
R30	Characteristic resistance: $F_{Rk,fi30}^0$ ¹⁾	[kN]	--	0.4	0.9	1.7	3.1	4.9
R60	Characteristic resistance: $F_{Rk,fi60}^0$ ¹⁾	[kN]	--	0.3	0.8	1.3	2.4	3.7
R90	Characteristic resistance: $F_{Rk,fi90}^0$ ¹⁾	[kN]	--	0.3	0.6	1.1	2.0	3.2
R120	Characteristic resistance: $F_{Rk,fi120}^0$ ¹⁾	[kN]	--	0.2	0.5	0.8	1.6	2.5
R30 to R120	Spacing $S_{cr,fi}$	[mm]	--	120	160	200	260	320
R120	Edge distance $C_{cr,fi}$	[mm]	--	60	80	100	130	160

¹⁾ In absence of other national regulations the partial safety factor for resistance under fire exposure $\gamma_{M,fi} = 1.0$ is recommended.

²⁾ If fire attack is from more than one side, the design method may be taken if edge distance of the anchor is $c \geq 300$

EDI, EDL anchor

Performances

Characteristic resistances

Annex C2