



**INSTITUTO DE CIENCIAS  
DE LA CONSTRUCCIÓN  
EDUARDO TORROJA**

C/ Serrano Galvache n. 4. 28033 Madrid (Spain)  
Tel.: (34) 91 302 04 40 / Fax: (34) 91 302 07 00  
[direccion.ietcc@csic.es](mailto:direccion.ietcc@csic.es) [www.ietcc.csic.es](http://www.ietcc.csic.es)



## European Technical Assessment

**ETA 15/0015**  
**of 03/ 05/ 2017**

English translation prepared by IETcc. Original version in Spanish language

### General Part

**Technical Assessment Body issuing the ETA and designated according to Article 29 of the Regulation (EU) Nº305/2011:**

Instituto de Ciencias de la Construcción Eduardo Torroja (IETcc)

**Trade name of the construction product**

**Sistema ISOLXTREM**

**Product family to which the construction product belongs**

External Thermal Insulation Composite System with rendering for use on building walls

**Manufacturer**

**ESTABLECIMIENTOS BAIXENS, S.L**  
Pol. Ind. MONCARRA s/n 46230 ALGINET (Valencia). Spain.

**Manufacturing plant(s)**

Pol. Ind. MONCARRA s/n 46230 ALGINET (Valencia). Spain.

**This European Technical Assessment contains**

10 pages including 2 Annexes which form an integral part of this assessment.  
Annex 3. Contain confidential information and is not included in the ETA when that assessment is publicly available.

**This European Technical Assessment is issued in accordance with regulation (EU) No 305/2011, on the basis of**

Guideline for European Technical Approval (ETAG) nº 004 ed. 2013, used as European Assessment Document (EAD)

**This version replaces**

ETA 12/0151 issued on 26/04/2012

Translations of this European Technical Assessment in other languages shall fully correspond to the original issued document and should be identified as such.

Communication of this European Technical Assessment, including transmission by electronic means, shall be in full (excepted the confidential Annex(es) referred to above). However, partial reproduction may be made, with the written consent of the issuing Technical Assessment Body. Any partial reproduction has to be identified as such.

This European Technical Assessment may be withdrawn by the issuing Technical Assessment Body, in particular pursuant to information by the Commission according to Article 25 Paragraph 3 of Regulation (EU) No 305/2011.

## SPECIFIC PARTS OF THE EUROPEAN TECHNICAL ASSESSMENT

### 1 Technical description of the product

The External Thermal Insulation Composite System (from now on, referred to as ETICS) "ISOLXTREM" is designed and installed in accordance with the manufacturer, design and installation instructions, deposited at the IETcc.

It is made up on site from these components. The manufacturer is ultimately responsible for the ETICS ISOLXTREM, which is a bonded system with supplementary mechanical fixings with EPS panel and mechanically fixed ETICS with supplementary adhesive on MW panel, the minimum number of fasteners per square metres are 6 for EPS and MW.

This ETICS comprises the following components, which are factory produced by the manufacturer or a supplier.

	Components	Coverage Aprox (kg/m <sup>2</sup> )	Thickness Aprox [mm]
Insulation material with associated method of fixing	<b>ISOLXTREM Panel EPS:</b> Bonded Board of Expanded polystyrene (EPS) (EN 13163) with supplementary mechanical fixings (minimum 6 fasteners/m <sup>2</sup> )	0,2- 6	10 - 300
	<b>ISOLXTREM Panel MW.</b> Mechanically fixed Mineral wool (MW) (EN 13162) with supplementary adhesive (minimum 6 fasteners/m <sup>2</sup> ) <sup>1</sup>	7,5- 30	50 - 200
Base coat	<b>Adhesive: ISOLXTREM POLIESTIREX</b> Minimum bonded surface: 40 % for EPS and 80% for MW. (cement based mortar in powder requiring addition and mixing with 22,0 ± 1,0% water.	1,3-1,5 (per mm thickness	3,0-5,0
Glass fibre mesh	<b>ISOLXTREM POLIESTIREX</b>	0,15/ 0,36	0,5
Primer coat	<b>Malla ISOLXTREM.</b> Glass fibre mesh resistant to the alkalis	0,20	--
Finishing coat	<b>ISOLXTREM MICROPRIMER.</b> Acrylic binder based painter which may require optionally 5% water <b>ISOLXTREM RTX / ISOLXTREM SILOXANE TEHCNOLOGY</b> Acrylic binder based ready to use paste with 3 different size grading particles ISOLXTREM RTX PX-20F// ISOLXTREM SILOXANE TEHCNOLOGY PX-28F (1 mm), ISOLXTREM RTX PX-20 M/ ISOLXTREM SILOXANE TEHCNOLOGY PX-28M (1,5 mm) and ISOLXTREM RTX PX-20 G /ISOLXTREM SILOXANE TEHCNOLOGY PX-28G (2 mm) <b>ISOLXTREM RTX LIGERO PX-20L /ISOLXTREM SILOXANE TEHCNOLOGY PX-28L.</b> Acrylic binder based ready to use paste	0,5 – 2,3	0,5 - 7
Fasteners	<b>TACOS DE FIJACIÓN MECÁNICA TTH 10/60:</b> Plastic anchors (expansion element and sleeve) for insulation material with different lengths in relation with thickness of insulation board.	Remain under the manufacturer responsibility	
Ancillary elements	<b>Aluminium profiles:</b> Base, corners, top and window sills, and its fixing devices		

### 2 Specification of the intended use in accordance with the applicable EAD

This ETICS is intended to be used as external thermal insulation for building walls. The walls are made of masonry (bricks, blocks...), or concrete (cast on site or as prefabricated panels) with a reaction to fire classification A1 to A2-s2,d0 according to EN 13501-1 or A1 according to the EC decision 96/603/EC as amended. The ETICS is designed to give the wall to which is applied satisfactory thermal insulation.

This ETICS is made of non load-bearing construction elements. It does not contribute directly to the stability of the wall on which is installed, but it can contribute its durability by providing enhanced protection from the effect of weathering. The minimum thermal resistance of the ETICS shall be  $\geq 1,0 \text{ m}^2\text{K/W}$ .

This ETICS can be used on new or existing (retrofit) vertical walls. It can also be used on horizontal or inclined surfaces which are not exposed to precipitation. The ETICS is not intended to ensure the airtightness of the building structure.

Design and installation of ETICS should take into account principles laid down in chapter 7 of ETAG 004 and shall be done in accordance with national instructions. This ETA covers application of bonded ETICS where the concrete for testing of bond strength is representative for masonry or concrete. For bonded applications onto other substrates (e.g. organic paints or ceramic tiles), testing on the job site is necessary.

The provisions made in this ETA are based on an assumed working life of 25 years as minimum, provided that the conditions laid down for the installation, appropriate use, maintenance and repair are met. The indications given on the working life cannot be interpreted as a guarantee given by the producer, but are to be regarded only as a means for choosing the right product in relation to the expected economically reasonable working life of the works.

<sup>(1)</sup> The numbers of fasteners used with MW must comply with the National requirements.

**Installation.** The ETICS is installed on site. It is the responsibility of the manufacturer to guarantee that the information about design and installation of this ETICS is effectively communicated to the concerned people. This information can be given using reproductions of the respective parts of this ETA. Besides, all the data concerning the execution shall be clearly indicated on the packaging and/or the enclosed instruction sheets using one or several illustrations.

The wall on which the ETICS is applied shall be sufficiently stable and airtight. Its stiffness shall be large enough to ensure that ETICS is not subjected to deformations, which could lead to damage. The requirements given in ETAG 004, chapter 7 have to be considered.

Design. In any case, the user shall comply with the national regulations and particularly concerning fires and wind load resistance. Only the components described in clause 1 with characteristics according to clause 3 of this ETA can be used for this ETICS.

The works including the details (connection, joint,..) shall be designed in order to avoid water penetration behind the system. The minimal surface area for the bonded ETICS, and the method of bonding shall comply with the characteristics of the ETICS as well as the national regulations. In any case, the minimal surface shall be at least 40 % for EPS and 80% for MW. Besides, the numbers of fasteners used with MW must comply with the National requirements.

Execution. The recognition and preparation of the substrate as well as the generalities about the execution of the ETICS shall be carried out in compliance with:

- Chapter 7 of the ETAG. 004, with imperative removal of any existing paint finish or renders which may difficult the bond resistance of the system.
- Corresponding national regulations.

The particularities in execution linked to the method of bonding/ mechanically fixings and the application of the rendering system shall be handled in accordance with manufacturer prescriptions. In particular it is suitable to comply with the quantities of rendering applied, the thickness regularity and the drying periods between layers.

**Use, maintenance and repair of the works.** It is accepted that the finishing coats shall normally be maintained in order to fully preserve the system's performance. Maintenance will include at least:

- The repairing of localised damaged areas due to accidents
- The application of various products or paints, possibly after washing or "ad hoc" preparation.

Necessary repairs should be done rapidly. It is important to be able to carry out maintenance as far as possible using readily available products and equipment, without spoiling appearance.

### 3 Performance of the product and references to the methods used for its assessment

The identification tests and the assessment for the intended use of this ETICS according to the Essential Requirements were carried out in compliance with the ETA Guidance n. 004: External Thermal Insulation Composite Systems with Rendering- edition February 2013 (called ETAG 004, in this ETA).

#### 3.1 ETICS Characteristics

Mechanical resistance and stability (BWR 1). No relevant.

Safety in case of fire ((BWR 2). (EN 13501-1). Fire reaction (EN 13501-1)

System composition		Finishing coat	Euroclass
Adhesive/ base coat" <b>ISOLXTREM POLIESTIREX</b> + One finishing layers	EPS boards (thickness 60 mm)	ISOLXTREM RTX / ISOLXTREM SILOXANE TEHCNOLOGY	B-s1,d0
		ISOLXTREM RTX LIGERO PX-20L /ISOLXTREM SILOXANE TEHCNOLOGY PX-28L	B-s1,d0
	MW boards (thickness 60 mm)	ISOLXTREM RTX / ISOLXTREM SILOXANE TEHCNOLOGY	B-s1,d0
		ISOLXTREM RTX LIGERO PX-20L /ISOLXTREM SILOXANE TEHCNOLOGY PX-28L	B-s1,d0

Hygiene, health and environment (BWR 3)

#### Water absorption

Requirements	ISOLXTREM RTX / ISOLXTREM SILOXANE TECHNOLOGY	ISOLXTREM RTX LIGERO / PX-28L
After 1 h: < 1 kg/m <sup>2</sup>	After 1h < 1	
After 24 h: <0,5 kg/m <sup>2</sup>	After 24h <0.5	

**Hygrothermal behaviour.** It has been assessed on one rig. During heat rain and heat – cold cycles, none of the following defects occurs during testing: Blistering or peeling of any finishing; Failure or cracking associated with joints between insulation product boards or profiles fitted with system; Detachment of render and cracking allowing water penetration to the insulation layer.

This system is therefore assessed as resistant to hygrothermal cycles.

**Freeze / thaw behaviour.** The water absorption of the base coat and of rendering system is less than 0.5 kg/m<sup>2</sup> after 24 hours and so the system can be assessed as freeze/thaw resistant without any further testing.

**Impact resistance.** The resistance to hard body impacts (3 and 10 Joules) tests carried out on samples of systems compositions lead to the following categories:

Insulation	ISOLXTREM RTX/ ISOLXTREM SILOXANETECHNOLOGY					
	PX-20G / PX-28G (2mm)		PX-20F / PX-28F (1,2mm)		PX-20L Ligeró / PX-28L	
	Malla ISOLXTREM	Double Malla ISOLXTREM	Malla ISOLXTREM	Double Malla ISOLXTREM	Malla ISOLXTREM	Double Malla ISOLXTREM
EPS	II	II	III	III	III	III
MW	II	I	II	II	II	I

#### Water vapour permeability

Equivalent air thickness	ISOLXTREM RTX / SILOXANE T.	ISOLXTREM RTX LIGERO / SILOXANE T. LIGERO
≤ 2 m (EPS) // ≤ 1 m (MW)		≤ 1 m

**Dangerous substances.** This system complies with the provisions of Guidance Paper H<sup>(2)</sup>. A declaration of conformity in this respect was made by the manufacturer. In addition to the specific clauses relating to dangerous substances contained in this ETA, there may be other requirements applicable to the ETICS falling within its scope (e.g. transposed European legislation and national laws, regulations and administrative provisions). In order to meet the provisions of the EU Regulations 305/11, these requirements need also to be complied with, when and where apply.

#### Safety in use (BWR 4)

**Bond strength: Base coat onto insulation board.** The tests were performed on samples of EPS and MW insulation boards faced with base coat and in all cases breakage location was 100% on insulation:

Base coat onto insulation board (MPa)			
Thermal insulation	Initial state	After hygrothermal cycles (on the rigs)	After free/thaw cycles (on the samples)
EPS	≥ 0,08	≥ 0,08	-----
MW	0,01	0,01	-----

**Bond strength: Adhesive onto insulation board.** The tests were performed on samples of EPS and MW insulation boards faced with base coat and in all cases breakage location was 100% on insulation:

Adhesive onto insulation board (MPa)				
Adhesive	Thermal insulation	Initial state	Immersion 48 h and 2 h drying	Immersion 48 h and 7 d drying
ISOLXTREM POLIESTIREX	EPS	≥ 0,08	≥ 0,03	≥ 0,08
	MW	0,01	0,01	0,01

#### Bond strength: Adhesive onto concrete

Adhesive onto concrete (MPa)		
Initial state	Immersion 48 h and 2 h drying	Immersion 48 h and 7 d drying
≥ 0,25	≥ 0,08	≥ 0,25

The minimal bonded surface S, which shall exceed 40% for EPS is calculated as follows:  $S (\%) = [0,03 * 100] / B$ . Where: B: minimum mean failure resistance of the adhesive to the insulation product in dry conditions expressed in MPa and 0,03 MPa correspond to the minimum requirements.

**Displacement test of the fasteners.** NPA since the bonded area exceeds 20 %

#### Pull-through of the fasteners

Values (N/ fastener)	Dry conditions	Wet conditions
Minimal	305	370
Mean	510	553

The mineral wool used in the test has 6 cm of thickness. The test results are also valid for Insulation product of the same type with ≥ thickness and/or higher tensile strength perpendicular to the faces and Anchors with ≥ plate diameter and/or the same or higher plate Stiffness (see EOTA Technical Report n° 26).

(2) *Guidance Document H: "A harmonized approach related to dangerous substances under the Construction Products Directive".*

Protection against noise (BWR 5). NPA

Energy economy and heat retention (BWR 6)

**Thermal resistance.** The additional thermal resistance  $R_{ETICS}$  provided by the ETICS to the substrate wall is calculated in accordance with EN ISO 6946 from the nominal value of the insulation product's thermal resistance  $R_D$  given accompanied to the CE marking and from the thermal resistance of the rendering system  $R_{render}$  which is about 0,02 m<sup>2</sup>K/W.

$$R_{ETICS} = R_D + R_{render}$$

The thermal bridges caused by mechanical fixing devices influence the thermal transmittance of the entire wall and shall be taken into account using the following calculation:

$$U_c = U + \Delta U \text{ (W/m}^2\text{K)},$$

$U_c$ : Corrected thermal transmittance (W/(m<sup>2</sup>.K)) of the entire wall, including thermal bridges.

$U$ : thermal transmittance of the entire wall, including ETICS, without thermal bridges) (W/(m<sup>2</sup>.K):

$$U = \frac{1}{R_i + R_{render} + R_{substrate} + R_{se} + R_{si}}$$

$R_i$ : thermal resistance of the insulation product //  $R_{render}$ : thermal resistance of the render (about 0,02 (m<sup>2</sup>.K)/W).

$R_{substrate}$ : thermal resistance of the substrate of the building (concrete, brick...)(m<sup>2</sup>.K)/W //

$R_{se}$ : external superficial thermal resistance ((m<sup>2</sup>.K)/W). //  $R_{si}$ : internal superficial thermal resistance ((m<sup>2</sup>.K)/W).

$\Delta U$ : Correction term of the thermal transmittance for mechanical fixing devices

$$\Delta U = X_p \cdot n,$$

$n$ : number of anchors (through insulation product) per m<sup>2</sup> //  $X_p$ : point thermal transmittance value of the anchor (0.002 W/K).

Aspect of durability and serviceability

**Bond strength after ageing.** In all cases breakage location was 100% on EPS and MW:

Rendering system (base coat + finishing coat)	Thermal insulation	After Hydrothermal cycles (rigs) (MPa)
ISOLXTREM RTX / SILOXANE TECHNOLOGY	EPS	≥ 0,08
	MW	0,01
ISOLXTREM RTX LIGERO / PX-28L	EPS	≥ 0,08
	MW	0,01

### 3.2 Characteristics of the components

Detailed information on the chemical composition and other identifying characteristics of the components, following Annex C of ETAG 004, has been deposited at the IETcc. Further information can be observed from the product data sheets, which are part of the Technical Documentation for this ETA.

**Insulation product.** Factory-prefabricated, uncoated boards made of EPS and MW, having the description, characteristics and performances (as minimum) defined in the table below:

Characteristics	Standard	EPS	MW
Reaction to fire Euroclass	EN 13501-1	B1	A1
Length (mm) / Tolerance type	EN 822	1000 / L2	1200
Width (mm) / Tolerance type	EN 822	500 / W2	600
Thickness (mm) / Tolerance type	EN 823	10 a 300 / T2	50-200 / T5
Squareness	EN 824	S2	-----
Flatness	EN 825	P4	-----
Density (kg/m <sup>3</sup> )	EN 1602	15- 20	150/95
Thermal conductivity a 10 °C (W/m.K)	EN 12667 o EN 12939	0,04	0,036
Dimensional stability under Temperature and humidity specific conditions	EN 1604	DS(70,-)2 DS (N) 2	DS (H)
Tensile strength perpendicular to the faces in dry conditions (N/mm <sup>2</sup> )	EN 1607	≥ TR 100	≥ TR 7,5
Water absorption ((partial immersion) (kg/m <sup>2</sup> )	EN 1609	<1	< 1
Water vapour diffusion (μ)	EN 12086	40 a 50	1
Shear strength (N/mm <sup>2</sup> )	EN 12090	0,1 ≥ 0,02	-----
Shear modulus (N/mm <sup>2</sup> )	EN 12090	≥ 1	-----

**Render.** Render strip tensile resistance: NPA

**Fasteners.** Fastener with CE marking with ETA n° 09/0318. Plate dimensions of 60 mm diameter and plate and Stiffness 0,9 kN/mm<sup>2</sup>.

**Glass fibre mesh.** Tearing strength after ageing of the glass fibre mesh was tested according to the ETAG 004:

Status	Units	Malla ISOLXTREM	
		Warp direction	Weft direction
Initial	N / mm	≥ 20	
Ageing	N / mm	≥ 20	
	Resistencia Residual (%)	≥ 50	

#### 4 Assessment and verification of constancy of performance (AVCP) system applied, with reference to its legal base

**System of attestation of conformity.** According to the decision 97/556/EC of the European Commission <sup>(3)</sup> amended by 2001/596/EC <sup>(4)</sup> the system of assessment and verification of constancy of performance (see Annex V to Regulation (EU) n° 305/2011) given in the following table applies.

Product	Intended uses	Level or Classes	System
ISOLXTREM	External Thermal Insulation Composite System with rendering for use on building walls	Any	2+

This system of attestation of conformity +2 is defined as follows:

Tasks for the manufacturer: Initial type-testing of the product, Factory production control and Testing of samples taken at the factory in accordance with a prescribed test plan.

Tasks for the notified body: Certification of factory production control on the basis of:

- Initial inspection of factory and of factory production control.
- Continuous surveillance (annual), assessment and assessment of factory production control.

#### 5 Technical details necessary for the implementation of the AVCP system, as provided for the applicable EAD

The ETA is issued for this kit on the basis of agreed data/information, deposited at IETcc, which identifies the product that has been assessed and judged. It is the manufacturer's responsibility to make sure that all those who use the kit are appropriately informed of specific conditions according to sections 1, 2, 4 and 5 including the annexes of this ETA. Changes to the ETICS or the components or their production process, should be notified to the IETcc before the changes are introduced. IETcc will decide whether or not such changes affect the ETA and if so whether further assessment or alterations to the ETA shall be necessary.

##### 5.1 Tasks of the manufacturer

**Factory production control.** The manufacturer shall exercise permanent internal control of production. All the elements, requirements and provisions adopted by the manufacturer shall be documented in a systematic manner in the form of written policies and procedures, including records of results performed. This production control system shall ensure that the product is in conformity with this ETA.

The manufacturer may only use components stated in the technical documentation of this ETA including Control Plan. The incoming raw materials are subjected to verifications by the manufacturer before acceptance.

For the components of the ETICS which the manufacturer does not manufacture by himself, he shall make sure that factory production control carried out by the other manufacturers gives the guarantee of the components compliance with the ETA.

The factory production control shall be in accordance with the Control Plan<sup>(5)</sup> which is part of the Technical Documentation of this ETA. The Control Plan has been agreed between the manufacturer and the IETcc and is laid down in the context of the factory production control system operated by the manufacturer and deposited at the IETcc. The results of factory production control shall be recorded and evaluated in accordance with the provisions of the Control Plan.

**Initial type-testing of the product.** Initial type-testing carried out by the IETcc is that set out in chapter 5 of the guideline for External Thermal Insulation Composite System with rendering for use on building walls (ETAG 004). The IETcc assessed the results of these tests in accordance with chapter 6 of this Guide, as part of the ETA issuing procedure.

<sup>(3)</sup> Official Journal of the European Communities L229/14 of 20.08.1997

<sup>(4)</sup> Official Journal of the European Communities L209/33 of 02.08.2001

<sup>(5)</sup> The control plan is a confidential part of this European Technical Assessment and only handed over to the notified body involved in the procedure of attestation of conformity. See section 3.2.2.

The verifications underlying this ETA have been furnished on samples from the current production, these will replace the initial type-testing carried. After changing the production process or starting the production in another manufacturing plant the initial type-test shall be repeated.

**Other tasks of manufacturer.** The manufacturer shall, on the basis of a contract, involve a body which is notified for the tasks referred to in section 4 in the field of ETICS in order to undertake the actions laid down in this clause. For this purpose, the control plan shall be handed over by the manufacturer to the notified bodies involved.

For initial type - testing of the ETICS and the components the results of the tests performed as part of the assessment for the ETA shall be used unless there are changes in the production line or plant. In such cases the necessary initial type- testing has to be agreed with the IETcc.

The manufacturer shall make a declaration of conformity, stating that the ETICS is in conformity with the provisions of this ETA.

**5.2** Tasks of notified bodies. The notified body shall perform:

**Initial inspection of factory and of factory production control.** The Notified Body shall ascertain that, in accordance with the Control Plan, the factory (in particular the employees and the equipment) and the factory production control are suitable to ensure continuous and orderly manufacturing of the components according to the specifications mentioned in clause 2 of this ETA.

**Continuous surveillance, assessment and assessment of factory production control,** in accordance with the provisions laid down in the control plan, at least one per year.

The notified body shall retain the essential points of its actions referred to above and state the results obtained and conclusions drawn in a written report. The notified certification body involved by the manufacturer shall issue an EC Certificate of factory production control stating the conformity of the provisions of this ETA.

In cases where the provisions of the ETA and its control plan are no longer fulfilled the notified certification body shall withdraw the certificate of conformity and inform to IETcc without delay.

Issued in Madrid on 03/05/ 2017  
by



Instituto de Ciencias de la Construcción Eduardo Torroja

**CONSEJO SUPERIOR DE INVESTIGACIONES CIENTÍFICAS**

c/ Serrano Galvache 4. 28033 Madrid (Spain).

[director.ietcc@csic.es](mailto:director.ietcc@csic.es) [www.ietcc.csic.es](http://www.ietcc.csic.es)



On behalf of the Instituto de Ciencias de la Construcción Eduardo Torroja

Marta Mº Castellote  
Director



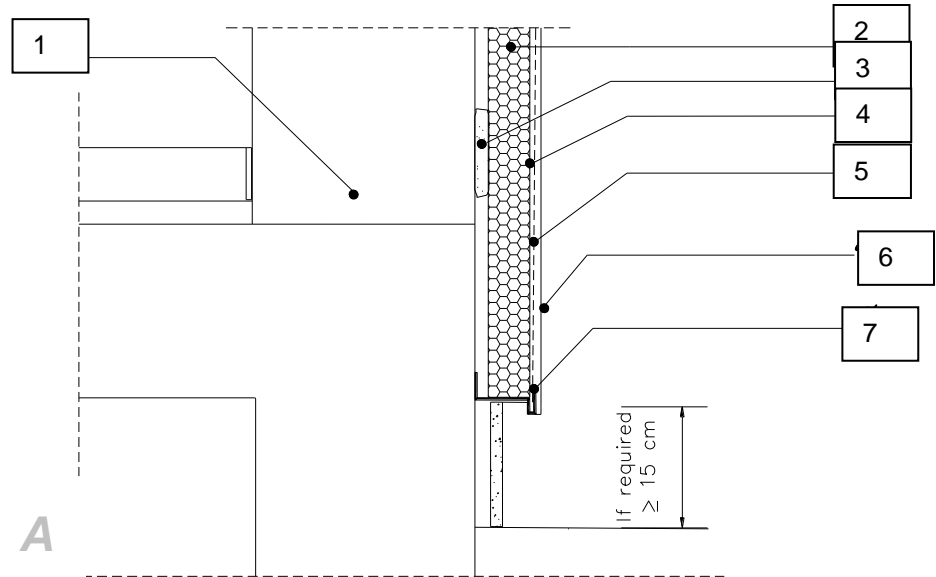
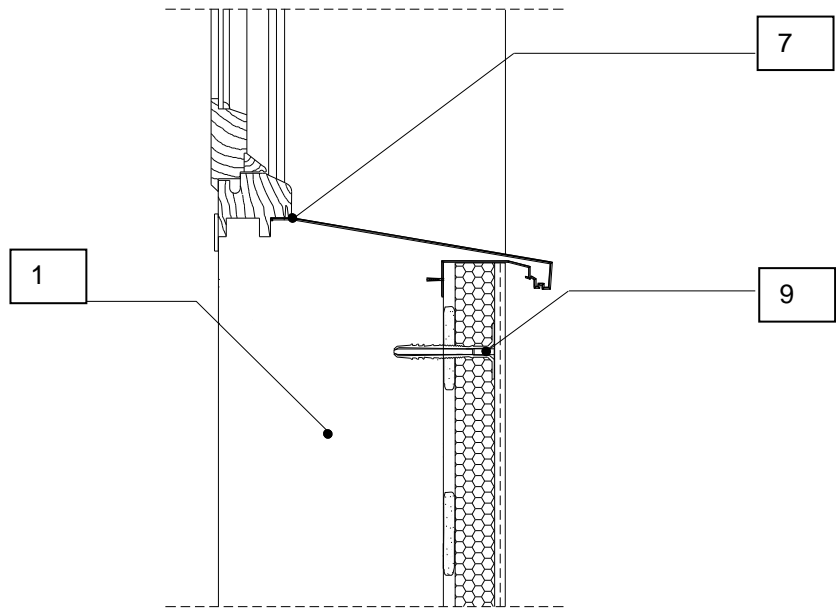

1. Substrate
2. EPS / MW board
3. Adhesive
4. Base coat )
5. Glass fibre standard mesh
6. Finishing coat
7. Aluminium base profile
9. Fixing

**DETAIL A: VERTICAL SECTION OF BASE AND APERTURE (WINDOW)**

**Annex 1**  
of European  
Technical Assessment

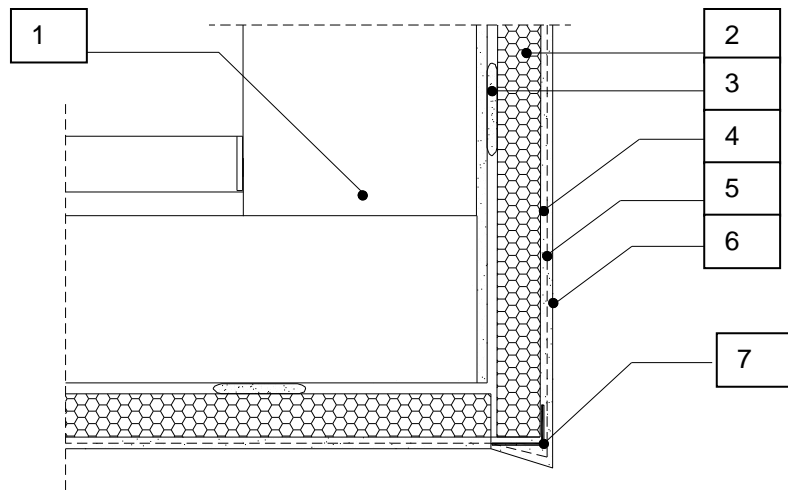

**B**

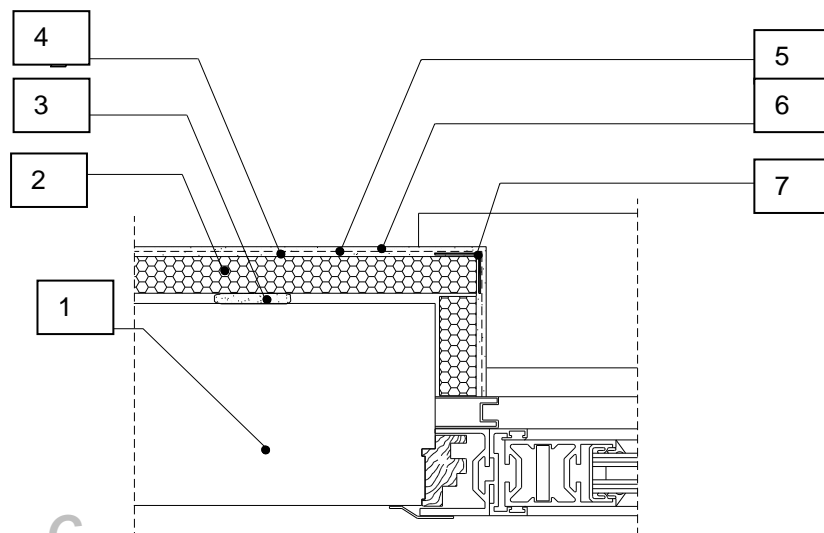

**C**

- 1. Substrate
- 2. EPS / MW boards
- 3. Adhesive
- 4. Base coat
- 5. Glass fibre standard mesh
- 6. Finishing coat
- 7. Aluminium corner profile

**DETAIL B: VERTICAL SECTION OF APERTURE (WINDOW)**  
**DETAIL C: HORIZONTAL SECTION OF APERTURE (WINDOW)**

**Annex 2**  
 of European  
 Technical Assessment