



**INSTITUTO DE CIENCIAS  
DE LA CONSTRUCCIÓN  
EDUARDO TORROJA**

C/ Serrano Galvache n. 4 28033 Madrid (Spain)  
Tel.: (34) 91 302 04 40 Fax: (34) 91 302 07 00  
[direccion.ietcc@csic.es](mailto:direccion.ietcc@csic.es) <https://dit.ietcc.csic.es>

**European Technical  
Assessment**

**ETA 23/0288  
of 27/03/2023**

English translation prepared by IETcc. Original version in Spanish language

**General Part**

**Technical Assessment Body issuing the ETA designated according to Art. 29 of Regulation (EU) 305/2011:**

Instituto de Ciencias de la Construcción Eduardo Torroja (IETcc)

**Trade name of the construction product:**

**BLPT, BLPC, BLPE**

**Product family to which the construction product belongs:**

Torque controlled expansion anchor made of galvanized steel of sizes M6, M8, M10, M12, M16 and M20 for use in concrete.

**Manufacturer:**

**Ningbo Bigood Metal Technology Co. Ltd.**  
No. 19, Eastern Section of Hongtang South Road  
Ningbo  
China  
website: [www.nbbigood.com](http://www.nbbigood.com)

**Manufacturing plants:**

Bigood plant 1

**This European Technical Assessment contains:**

11 pages including 3 annexes which form an integral part of this assessment.

**This European Technical Assessment is issued in accordance with regulation (EU) No 305/2011, on the basis of:**

European Technical Assessment EAD 330232-01-0601 "Mechanical Fasteners for use in concrete", ed. December 2019



*English translation prepared by IETcc*

This European Technical Assessment is issued by the Technical Assessment Body in its official language. Translations of this European Technical Assessment in other languages shall fully correspond to the original issued document and should be identified as such.

This European Technical Assessment may be withdrawn by the issuing Technical Assessment Body, in particular pursuant to information by the Commission according to article 25 (3) of Regulation (EU) No 305/2011.

Código seguro de Verificación : GEN-7f66-97bf-1f52-44f5-27cd-e30a-50d6-e6a1 | Puede verificar la integridad de este documento en la siguiente dirección : <https://portafirmas.redsara.es/pf/valida>

---

CSV : GEN-7f66-97bf-1f52-44f5-27cd-e30a-50d6-e6a1

DIRECCIÓN DE VALIDACIÓN : <https://portafirmas.redsara.es/pf/valida>

FIRMANTE(1) : ANGEL CASTILLO TALAVERA | FECHA : 29/03/2023 17:34 | Sin acción específica



## SPECIFIC PART

### 1. Technical description of the product

The Bigood BLPT heavy duty anchor in the range of M6, M8, M10, M12, M16 and M20 is an anchor made of galvanised steel. BLPT anchor has a hexagonal head, BLPC anchor has a countersunk head and the BLPE is the projecting bolt version. The anchor is installed into a predrilled cylindrical hole and anchored by torque-controlled expansion. The anchorage is characterised by friction between the expansion tube and the concrete.

Product and installation descriptions are given in annexes A1 and A2.

### 2. Specification of the intended use in accordance with the applicable European Assessment Document.

The performances given in section 3 are only valid if the anchor is used in compliance with the specifications and conditions given in annex B.

The verifications and assessment methods on which this European Technical Assessment is based lead to the assumption of a working life of the anchor of at least 50 years. The indications given on the working life cannot be interpreted as a guarantee given by the producer, but are to be regarded only as a mean to choosing the right products in relation to the expected economically reasonable working life of the works.

### 3. Performance of the product and references to the methods used for its assessment

#### 3.1 Mechanical resistance and stability (BWR 1)

Essential characteristic	Performance
Characteristic resistance to tension loads	See annex C2
Characteristic resistance to shear loads	See annex C3

#### 3.2 Safety in case of fire (BWR 2)

Essential characteristic	Performance
Reaction to fire	Anchorage satisfy requirements for class A1 according to EN 13501-1
Resistance to fire	See annex C4

### 4. Assessment and Verification of Constancy of Performances (hereinafter AVCP) system applied, with reference to its legal base

The applicable European legal act for the system of Assessment and Verification of Constancy of Performances (see annex V to Regulation (EU) No 305/2011) is 96/582/EC.

The system to be applied is 1.



**5. Technical details necessary for the implementation of the AVCP system, as provided for in the applicable European Assessment Document.**

The technical details necessary for the implementation of the AVCP system are laid down in the quality plan deposited at Instituto de Ciencias de la Construcción Eduardo Torroja.



Instituto de Ciencias de la Construcción Eduardo Torroja  
CONSEJO SUPERIOR DE INVESTIGACIONES CIENTÍFICAS

C/ Serrano Galvache n.º 4. 28033 Madrid.  
Tel: (+34) 91 302 04 40 Fax. (+34) 91 302 07 00

<https://dit.ietcc.csic.es>



On behalf of the Instituto de Ciencias de la Construcción Eduardo Torroja  
Madrid, 27<sup>th</sup> of March 2023

D. Ángel Castillo Talavera  
Director



**Product and installed condition**

BLPT anchor



BLPC anchor



BLPE anchor



Identification on anchor:

- Sleeve: outer diameter / total length / maximum fixture thickness to be fixed.
- Plastic ring: anchor name “BLP”, company logo

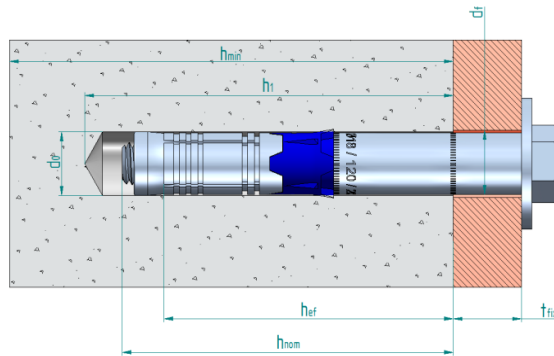

- $d_0$ : Nominal diameter of drill bit
- $d_i$ : Fixture clearance hole diameter
- $h_{ef}$ : Effective anchorage depth
- $h_1$ : Depth of drilled hole
- $h_{nom}$ : Overall anchor embedment depth in the concrete
- $h_{min}$ : Minimum thickness of concrete member
- $t_{fix}$ : Fixture thickness

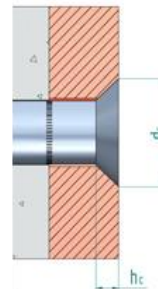

**BLPT anchor**

**Product description**

Installed condition

**Annex A1**



**Table A1: Materials**

Item	Designation	Material for BLPT	Material for BLPC	Material for BLPE
1	Bolt	DIN 931 ISO 898-1 class 8.8. Galvanized $\geq 5 \mu\text{m}$ ISO 4042 Zn5/An/T0	DIN 7991 ISO 898-1 class 10.9. Galvanized $\geq 5 \mu\text{m}$ ISO 4042 Zn5/An/T0	---
2	Projecting bolt	---	---	Threaded stud class 8.8 ISO 898-1. Galvanized $\geq 5 \mu\text{m}$ ISO 4042 Zn5/An/T0
3	Nut	---	---	DIN 934 class 8. Galvanized $\geq 5 \mu\text{m}$ ISO 4042 Zn5/An/T0
4	Washer	DIN 9021. Galvanized $\geq 5 \mu\text{m}$ ISO 4042 Zn5/An/T0	Special conical washer. Galvanized $\geq 5 \mu\text{m}$ ISO 4042 Zn5/An/T0	DIN 9021. Galvanized $\geq 5 \mu\text{m}$ ISO 4042 Zn5/An/T0
5	Sleeve	Carbon steel. Galvanized $\geq 5 \mu\text{m}$ ISO 4042 Zn5/An/T0		
6	Plastic ring	POM		
7	Expansion sleeve	Carbon steel. Galvanized $\geq 5 \mu\text{m}$ ISO 4042 Zn5/An/T0		
8	Cone	Hardened carbon steel. Galvanized $\geq 5 \mu\text{m}$ ISO 4042 Zn5/An/T0		

**BLPT anchor**

**Product description**

Materials

**Annex A2**



### **Specifications of intended use**

#### **Anchorage subjected to:**

- Static or quasi static loads
- Resistance to fire exposure up to 120 minutes

#### **Base materials:**

- Reinforced or unreinforced normal weight concrete without fibres according to EN 206-1:2013 + A1:2016
- Strength classes C20/25 to C50/60 according to EN 206-1:2013 + A1:2016
- Cracked or uncracked concrete

#### **Use conditions (environmental conditions):**

- Anchorages subjected to dry internal conditions.

#### **Design:**

- Anchorages are designed under the responsibility of an engineer experienced in anchorages and concrete.
- Verifiable calculation rules and drawings are prepared taking into account of the loads to be anchored. The position of the anchor is indicated on the design drawings (e.g., position of the anchor relative to reinforcement or to supports, etc.).
- Anchorages under static or quasi-static actions are designed for design method A in accordance with EN 1992-4:2018
- Anchorages under fire exposure are designed in accordance with EN-1992-4:2018. It must be ensured that local spalling of the concrete cover does not occur.

#### **Installation:**

- Hole drilling by rotary plus hammer mode.
- Anchor installation carried out by appropriately qualified personal and under the supervision of the person responsible for technical matters of the site.
- In case of aborted hole: new drilling at a minimum distance away of twice the depth of aborted hole or smaller distance if the aborted hole is filled with high strength mortar and if under shear or oblique tension load it is not the direction of the load application.

**BLPT anchor**

**Intended use**

**Specifications**

**Annex B1**

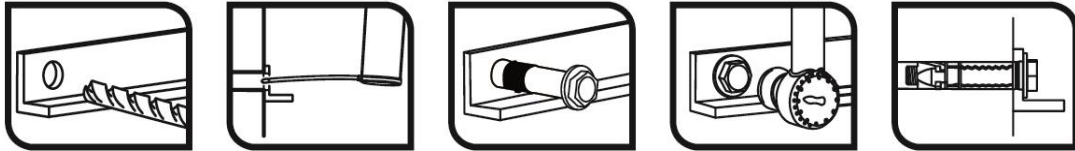

**Table C1: Installation parameters**

Installation parameters			Performances					
			M6 Ø10	M8 Ø12	M10 Ø16	M12 Ø18	M16 Ø24	M20 Ø28
$d_0$	Nominal diameter of drill bit:	[mm]	10	12	16	18	24	28
$d_f$	Fixture clearance hole diameter $\leq$	[mm]	12	14	18	20	26	31
$T_{inst}$	Nominal installation torque:	[Nm]	15	30	50	80	160	240
$h_{min}$	Minimum thickness of concrete member:	[mm]	100	120	140	170	200	250
$h_1$	Depth of drilled hole $\geq$	[mm]	70	85	95	110	130	160
$h_{nom}$	Overall anchor embedment depth in the concrete:	[mm]	59	72	83	97	117	146
$h_{ef}$	Effective anchorage depth:	[mm]	50	60	70	85	100	125
$t_{fix}$	Thickness of fixture <sup>1)</sup> $\leq$	[mm]	L - 60	L - 75	L - 85	L - 100	L - 120	L - 150
$s_{min}$	Minimum allowable spacing:	[mm]	100	120	175	200	220	320
$c_{min}$	Minimum allowable edge distance:	[mm]	50	60	70	80	100	160
$d_c$	Diameter of countersunk head in the fixture:	[mm]	16.4	20.6	26.8	30.8	38.8	44.8
$h_c$	Height of countersunk head in the fixture:	[mm]	3.2	4.3	5.4	6.4	7.4	8.4
SW	BLPT / BLPE socket size:	[--]	10	13	17	19	24	30
SW	BLPC hexagonal recess:	[--]	4	5	6	8	10	12

<sup>1)</sup> L = total anchor length

**Installation process**



**BLPT anchor**

**Performances**

Installation parameters and installation procedure

**Annex C1**





**Table C2: Characteristic values to tension loads of design method A according to EN 1992-4**

Characteristic values of resistance to tension loads of design according to design method A		Performances							
		M6 Ø10	M8 Ø12	M10 Ø16	M12 Ø18	M16 Ø24	M20 Ø28		
<b>Tension loads: steel failure</b>									
$N_{Rk,s}$	Characteristic resistance:	[kN]	16.1	29.3	46.4	67.4	126.0	196.0	
$\gamma_{Ms}$	Partial safety factor <sup>2)</sup> :	[-]	1.5						
<b>Tension loads: pull-out failure in concrete</b>									
$N_{Rk,p,ucr}$	Characteristic resistance in C20/25 uncracked concrete:	[kN]	15.0	20.0	-- <sup>1)</sup>				
$N_{Rk,p,cr}$	Characteristic resistance in C20/25 cracked concrete:	[kN]	-- <sup>1)</sup>						
$\gamma_{ins}$	Installation safety factor:	[-]	1.0	1.0	1.0	1.0	1.2	1.2	
$\psi_c$	Increasing factor for $N^0_{Rk,p}$ :	C30/37	[-]	1.22	1.22	1.22	1.22	1.08	1.08
		C40/50	[-]	1.41	1.41	1.41	1.41	1.15	1.15
		C50/60	[-]	1.58	1.58	1.58	1.58	1.20	1.20
<b>Tension loads: concrete cone and splitting failure</b>									
$h_{ef}$	Effective embedment depth:	[mm]	50	60	70	85	100	125	
$K_{ucr,N}$	Factor for uncracked concrete:	[-]	11.0						
$K_{cr,N}$	Factor for cracked concrete:	[-]	7.7						
$\gamma_{ins}$	Installation safety factor:	[-]	1.0	1.0	1.0	1.0	1.2	1.2	
$S_{cr,N}$	Concrete cone failure:	[mm]	3 x $h_{ef}$						
$C_{cr,N}$		[mm]	1.5 x $h_{ef}$						
$S_{cr,sp}$	Splitting failure:	[mm]	205	245	285	345	410	510	
$C_{cr,sp}$		[mm]	105	125	145	175	205	255	

<sup>1)</sup> The pull-out failure mode is not decisive.

<sup>2)</sup> In absence of other national regulations

**Table C3: Displacements under tension load**

Displacements under tension loads		Performances						
		M6 Ø10	M8 Ø12	M10 Ø16	M12 Ø18	M16 Ø24	M20 Ø28	
N	Service tension load in uncracked concrete C20/25 to C50/60:	[kN]	7,43	10,24	13,71	18,38	19,52	27,30
$\delta_{N0}$	Short term displacement:	[mm]	1,18	2,02	1,79	1,15	2,46	2,12
$\delta_{N\infty}$	Long term displacement:	[mm]	2,68	2,68	2,68	2,68	2,68	2,68
N	Service tension load in cracked concrete C20/25 to C50/60:	[kN]	5,81	7,62	9,62	12,86	13,65	19,09
$\delta_{N0}$	Short term displacement:	[mm]	1,75	2,69	2,57	3,53	1,76	2,41
$\delta_{N\infty}$	Long term displacement:	[mm]	3,75	4,69	4,57	5,53	3,76	4,41

BLPT anchor

Performances

Characteristic values for tension loads

Annex C2



**Table C4: Characteristic values to shear loads of design method A according to EN 1992-4**

Characteristic values of resistance to shear loads of design according to design method A		Performances					
		M6 Ø10	M8 Ø12	M10 Ø16	M12 Ø18	M16 Ø24	M20 Ø28
<b>Shear loads: steel failure without lever arm</b>							
$V_{Rk,s}$	Characteristic resistance: [kN]	20.2	33.0	62.2	75.1	111.2	141.7
$k_7$	Ductility factor: [-]	1.0					
$\gamma_{Ms}$	Partial safety factor <sup>1)</sup> : [-]	1.25					
<b>Shear loads: steel failure with lever arm</b>							
$M^0_{Rk,s}$	Characteristic bending moment: [Nm]	12.2	30.0	59.8	104.8	266.4	519.3
$\gamma_{Ms}$	Partial safety factor <sup>1)</sup> : [-]	1.25					
<b>Shear loads: concrete pryout failure</b>							
$k_8$	Pryout factor: [-]	1.0	2.0	2.0	2.0	2.0	2.0
$\gamma_{ins}$	Installation safety factor: [-]	1.0					
<b>Shear loads: concrete edge failure</b>							
$l_f$	Effective length of anchor under shear loads: [mm]	50	60	70	85	100	125
$d_{nom}$	Outside anchor diameter: [mm]	10	12	16	18	24	28
$\gamma_{ins}$	Installation safety factor: [-]	1.0					

<sup>1)</sup> In absence of other national regulations

**Table C5: Displacements under shear load**

Displacements under shear loads		Performances					
		M6 Ø10	M8 Ø12	M10 Ø16	M12 Ø18	M16 Ø24	M20 Ø28
V	Service shear load in uncracked and cracked concrete C20/25 to C50/60: [kN]	9,62	15,71	29,62	35,76	44,13	56,23
$\delta_{V0}$	Short term displacement: [mm]	2,15	1,22	1,31	1,72	1,41	1,96
$\delta_{V\infty}$	Long term displacement: [mm]	3,23	1,83	1,96	2,58	2,11	2,93

**BLPT anchor**

**Performances**

Characteristic values for shear load.

**Annex C3**



**Table C8: Characteristic values for resistance under fire exposure**

Characteristic values under fire exposure			Performances					
			M6 Ø10	M8 Ø12	M10 Ø16	M12 Ø18	M16 Ø24	M20 Ø28
<b>Steel failure</b>								
$N_{Rk,s,fi}$	Characteristic tension resistance:	R30 [kN]	0,2	0,4	0,9	1,7	3,1	4,9
		R60 [kN]	0,2	0,3	0,8	1,3	2,4	3,7
		R90 [kN]	0,1	0,3	0,6	1,1	2,0	3,2
		R120 [kN]	0,1	0,2	0,5	0,8	1,6	2,5
$V_{Rk,s,fi}$	Characteristic shear resistance:	R30 [kN]	0,2	0,4	0,9	1,7	3,1	4,9
		R60 [kN]	0,2	0,3	0,8	1,3	2,4	3,7
		R90 [kN]	0,1	0,3	0,6	1,1	2,0	3,2
		R120 [kN]	0,1	0,2	0,5	0,8	1,6	2,5
$M^0_{Rk,s,fi}$	Characteristic bending resistance:	R30 [Nm]	0,2	0,4	1,1	2,6	6,7	13,0
		R60 [Nm]	0,1	0,3	1,0	2,0	5,0	9,7
		R90 [Nm]	0,1	0,3	0,7	1,7	4,3	8,4
		R120 [Nm]	0,1	0,2	0,6	1,3	3,3	6,5
<b>Pull out failure</b>								
$N_{Rk,p,fi}$	Characteristic resistance:	R30 to R120 [kN]	--1)					
<b>Concrete cone failure <sup>2)</sup></b>								
$N_{Rk,c,fi}$	Characteristic resistance:	R30 [kN]	3,0	4,8	7,1	11,5	17,2	30,1
		R60 [kN]						
		R90 [kN]						
		R120 [kN]	2,4	3,8	5,6	9,2	13,8	24,1
$S_{cr,N,fi}$	Critical spacing:	R30 to R120 [mm]	4 x $h_{ef}$					
$C_{cr,N,fi}$	Critical edge distance:	R30 to R120 [mm]	2 x $h_{ef}$					
$S_{min,fi}$	Minimum spacing:	R30 to R120 [mm]	100	120	175	200	220	320
$C_{min,fi}$	Minimum edge distance:	R30 to R120 [mm]	$C_{min} = 2 \times h_{ef}$ , if fire attack comes from more than one side, the edge distance of the anchor has to be $\geq 300$ mm and $\geq 2 \times h_{ef}$					
<b>Concrete pryout failure</b>								
$k_8$	Pryout factor:	R30 to R120 [-]	1.0	2.0	2.0	2.0	2.0	2.0

- 1) The pull-out failure mode is not decisive.
- 2) As a rule, splitting failure can be neglected since cracked concrete and reinforcement is assumed.
- 3) In absence of other national regulations the partial safety factor for resistance under fire exposure  $\gamma_{m,fi} = 1,0$  is recommended

**BLPT anchor**

**Performances**

Characteristic values for resistance to fire

**Annex C4**

