



**INSTITUTO DE CIENCIAS
DE LA CONSTRUCCIÓN
EDUARDO TORROJA**

C/ Serrano Galvache, 4. 28033 Madrid (Spain)
Tel.: (+34) 91 302 0440 www.ietcc.csic.es
gestiondit@ietcc.csic.es dit.ietcc.csic.es

European Technical Assessment

**ETA 22/ 0220
15/ 02/ 2023**

English translation prepared by IETcc. Original version in Spanish language

General Part

Technical Assessment Body issuing the European Technical Assessment:
Instituto de Ciencias de la Construcción Eduardo Torroja (IETcc)

Trade name of the construction product

TECTOR NATURTHERM

Product family to which the construction product belongs

External Thermal Insulation Composite System with rendering for use on building walls

Manufacturer

Holcim España, S.A.U.

Avenida de Manoteras 20 , Edificio Tokio 1º planta
28050 Madrid. Spain

GRAPHENSTONE

C/ Carpinteros n.º 25
41520 El viso del Alcor (Sevilla). Spain

Manufacturing plant(s)

Cantera el Cuchillo, Carretera N.301, km. 321,4, 02409
Hellín, Albacete. Spain

Poliviso, C. Carpinteros, 25,
41520, El Viso del Alcor, Sevilla. Spain

This European Technical Assessment contains

10 pages including 2 Annex which form an integral part of this assessment.
Annex 3 contains confidential information and is not included in the European Technical Assessment when that assessment is publicly disseminated

This European Technical Assessment is issued in accordance with Regulation (EU) No 305/2011, on the basis of

040083-00-0404:
External thermal insulation composite systems (ETICS) with renderings

Translations of this European Technical Assessment in other languages shall fully correspond to the original issued document and should be identified as such.

Communication of this European Technical Assessment, including transmission by electronic means, shall be in full (excepted the confidential Annex(es) referred to above). However, partial reproduction may be made, with the written consent of the issuing Technical Assessment Body. Any partial reproduction has to be identified as such.



Specific parts

1 Technical description of the product

The External Thermal Insulation Composite System (from now on, referred to as ETICS) "TECTOR NATURTHERM" is designed and installed in accordance with the manufacturer, design and installation instructions, deposited at the IETcc⁽¹⁾. It is made up on site from these components. The manufacturer is ultimately responsible for the ETICS.

SATE TECTOR NATURTHERM is defined as "bonded system with supplementary mechanical fixings" with is used with EPS-XPS panel, and "mechanically fixed ETICS with supplementary adhesive" with is used with MW panel. The minimum number of fasteners per square metres are 6 for EPS and MW and 8 fasteners for building higher than 24 m.

This ETICS comprises the following components, which are factory supplied by the manufacturer or a supplier.

Components		Coverage ([kg/m ²])	Thickness (mm)		
Thermal Insulation + method of fixing	Tector NATURTHERM PANEL EPS / EPS graphite: Bonded Board of Expanded polystyrene (EPS) (EN 13163) with supplementary mechanical fixings (minimum 6 fasteners/m ²)	0.15 – 6.0	20 - 100		
	Tector NATURTHERM PANEL XPS: Bonded Board of Extruded polystyrene (XPS) (EN 13164) with supplementary mechanical fixings (minimum 6 fasteners/m ²)	1.0 - 4.0	20 - 100		
	Tector NATURTHERM PANEL MW: Mechanically fixed Mineral wool (MW) (EN 13162) with supplementary adhesive (minimum 6 fasteners/m ²)	5.0- 24.0	50 - 240		
Adhesive	Tector Therm BC. Minimum bonded surface: 60 % for EPS/XPS and 80% for MW. Eco-planet Cement (30 % CO ₂ reduction) based mortar in powder requiring addition and mixing with 20,0 ± 1 % water	1.2 – 1.5 (powder, and per mm layer thickness)	≥ 3,0		
Base coat	Tector Therm BC + Tector NATURTHERM MALLA 160	1.2 – 1.5 (powder, and per mm layer thickness)	3 - 5		
Glass fibre mesh	Tector NATURTHERM MALLA 160. Standard glass fibre alkali resistant mesh	0.16	0.58		
	Other different mesh can be used in this ETICS, if they have the CE marking according to EAD 040016-00-0404 and the following characteristics				
	Characteristics		Values		
	Mesh size (mm)		(3.5 x 3.8) ± 0.5		
	Elongation after ageing (%)		≤ 3.8		
	Mass per unit area (g/m ²)		≥ 160		
Thickness		0.58 ± 0.2 mm			
Organic content		20 ± 4			
After ageing (alkali conditioning), the mean value of residual strength of the standard mesh (see EAD 1.3.8.1) in the weft and warp direction shall be at least: 50 % of the strength in the as-delivered state and ≥ 20 N/mm.					
Primer coat	Naturcolor Fondo. Acrylic binder based painter which may require optionally 10-15% water	0.35 – 0.4	----		
Finishing coat	Naturcolor Fondo + Naturmortar Acrílico	Based on acrylic emulsion modified with acrylic resin ready to use	1 - 4.0		
Fasteners	Plastic anchors (expansion element and sleeve) for insulation material with different lengths in relation with thickness of insulation board. For MW can is used an additional washer of 9 cm diameter				
	Fasteners	ETA nº	Diameter Plate (mm)	Stiffness (kN/mm)	Minimum tension load (N)*
	Tector NATURTHERM	16/ 0509	60	0,5	500
	Fijación.	17/ 0450	60	0,3	300
*These values show the minimum pull out of the fastener in the weakest support (enclosed in its ETA). Other higher values appear in their ETAs. Other fasteners can be used with CE marking (EAD 330196-00-0604). When it is used on MW boards, they have to have a plate dimension ≥ 60 mm diameter and Stiffness ≥ 0,3 kN/mm. An additional larger washer 9 -14 cm can be used with TECTOR NATURTHERM PANEL MW			Remain under the manufacturer responsibility		
Ancillary elements	Aluminium and PVC profiles: base, corners, top and window sills, expansion joint and its fixing devices				

⁽¹⁾ The technical documentation of this European Technical Assessment is deposited at the *Instituto de Ciencias de la Construcción Eduardo Torroja* (IETcc) and, as far as relevant for the tasks of the notified bodies involved in the attestation of conformity procedure, is handed over to the notified bodies.



2 Specification of the intended use in accordance with the applicable European Assessment Document (hereinafter EAD)

2.1 Intended use(s)

This ETICS is intended to be used as external thermal insulation for building walls. The walls are made of masonry (bricks, blocks...) or concrete (cast on site or as prefabricated panels) with a reaction to fire classification A1 to A2-s2,d0 according to EN 13501-1 or A1 according to the EC decision 96/603/EC as amended. The ETICS is designed to give the wall to which is applied satisfactory thermal insulation.

This ETICS is made of non-load bearing construction elements. It does not contribute directly to the stability of the wall on which is installed, but it can contribute its durability by providing enhanced protection from the effect of weathering.

This ETICS can be used on new or existing (retrofit) vertical walls. It can also be used on horizontal or inclined surfaces which are not exposed to precipitation. The ETICS is not intended to ensure the airtightness of the building structure.

This ETA covers application of ETICS on supports of masonry or concrete.

2.2 Relevant general conditions for the use of the kit

The provisions made in this European Technical Assessment are based on an assumed working life of 25 years from installation in the works, according to EAD 040083-00-0404, provided that the conditions lay down for the installation, packaging, transport and storage as well as appropriate use, maintenance and repair are met. In this respect.

The indications given on the working life cannot be interpreted as a guarantee given neither by the product manufacturer nor by EOTA nor by the Technical Assessment Body issuing this ETA, but are regarded only as a means for choosing the right product in relation to the expected economically reasonable working life of the works.

Installation. The ETICS is installed on site. It is the responsibility of the manufacturer to guarantee that the information about design and installation of this ETICS is effectively communicated to the concerned people. This information can be given using reproductions of the respective parts of this ETA. Besides, all the data concerning the execution shall be clearly indicated on the packaging and/or the enclosed instruction sheets using one or several illustrations.

The wall on which the ETICS is applied shall be sufficiently stable and airtight. Its stiffness shall be large enough to ensure that ETICS is not subjected to deformations, which could lead to damage.

Design. In any case, the user shall comply with the national regulations and particularly concerning fires and wind load resistance. Only the components described in clause 1 with characteristics according to clause 3 of this ETA can be used for this ETICS.

The works including the details (connection, joint,...) shall be designed in order to avoid water penetration behind the system. The minimal surface area for the bonded ETICS, and the method of bonding shall comply with the characteristics of the ETICS as well as the national regulations. In any case, the minimal surface shall be at least 60 % for EPS/XPS and 80 % for MW. Besides, the numbers of fasteners used with MW must comply with the National requirements⁽²⁾.

Execution. The recognition and preparation of the substrate as well as the generalities about the execution of the ETICS shall be carried out in compliance with the manufacturer prescriptions and the corresponding national regulations.

The particularities in execution linked to the method of bonding and the application of the rendering system shall be handled in accordance with manufacturer prescriptions. In particular, it is suitable to comply with the quantities of rendering applied, the thickness regularity and the drying periods between layers.

⁽²⁾ The value of the pull through to calculate the numbers of fasteners will be the minor value between the average value of pull through fastener-MW (defined in this ETA) and the average value pull out of the fastener-support (defined in its ETA).



Use, maintenance and repair of the works. It is accepted that the finishing coats shall normally be maintained in order to fully preserve the system's performance. Maintenance will include at least:

- The repairing of localised damaged areas due to accidents
- The application of various products or paints, possibly after washing or ad hoc preparation.

Necessary repairs should be done rapidly. It is important to be able to carry out maintenance as far as possible using readily available products and equipment, without spoiling appearance.

3 Performance of the product and references to the methods used for its assessment

The identification tests and the assessment for the intended use of this ETICS according to the Basic Work Requirements (BWR) were carried out in compliance with EAD 040083-00-0404, The characteristics of each system shall correspond to the respective values laid down in following tables of this ETA, checked by IETcc.

Methods of verification and of assessing and judging are listed afterwards.

3.1 Safety in case of fire (BWR 2)

Basic requirement for construction works 2: Safety in case of fire		
Essential characteristic	Relevant clause in EAD	Performance
Reaction to fire of ETICS	2.2.1.1	NPA
Reaction to fire of thermal insulation material	2.2.1.2	EPS: E XPS: E MW : A1
Facade fire performance	2.2.2	NPA
Propensity to undergo continuous smouldering of ETICS	2.2.3	NPA

3.2 Hygiene, health and environment (BWR 3)

Basic requirement for construction works 3: Hygiene, health, and the environment				
Essential characteristic	Relevant clause in EAD	Performance		
Content, emission and/or release of dangerous substances. Leachable substances	2.2.4	NPA. The leachable substances are not determined in accordance with this EAD		
Water absorption of the base coat and rendering system (kg/m ²)	2.2.5.1	Rendering		
		Tector Term BC	0,09	0,45
Water absorption of the thermal insulation	2.2.5.2	Naturcolor Fondo + Naturmortar Acrílico		
		Tector NATURTHERM PANEL EPS: EN ISO 29767: ≤ 1 kg/m ²	0,17	0,1
Water absorption of the thermal insulation	2.2.5.2	Tector NATURTHERM PANEL XPS: EN ISO 29767: ≤ 1 kg/m ²		
		Tector NATURTHERM PANEL MW: EN ISO 29767: ≤ 1 kg/m ²		
Water-tightness of the ETICS Hygrothermal behaviour	2.2.6	The ETICS is assessed resistant to hygrothermal cycles on a rig, passed the test without defects and without pass through of water		
Water tightness of the ETICS: Freeze-thaw behaviour	2.2.7	The water absorption of the base coat and of rendering system is less than 0.5 kg/m ² after 24 hours and so the system can be assessed as freeze/thaw resistant without any further testing		
Impact resistance (Category) (diameter impact (cm) at 3J -10 J)	2.2.8	Rendering		
		EPS / XPS / MW + Tector Term BC + finishing coat		
		Tector Term BC	II (1 / 5) NPA I (0 / 2)	NPA
		Naturcolor Fondo + Naturmortar Acrílico	I (0.9 / 1.4) II (1.8 / 4.1) I (0.9 / 2.5)	I (0.1 / 0) I (1 / 2) I (0.9 / 1.1)
Water vapour permeability of the rendering system	2.2.9.1	Base coat + finishing coat		
		(S _d , m)	Required	
Water vapour permeability of the rendering system	2.2.9.1	Tector Term BC	0,1	< 1
		Naturcolor Fondo + Naturmortar Acrílico	0,9	
Water vapour permeability of the thermal insulation	2.2.9.2	Tector NATURTHERM PANEL EPS: EN 12086: μ = 60		
		Tector NATURTHERM PANEL XPS: EN 12086: μ = 60		
		Tector NATURTHERM PANEL MW: EN 12086: μ = 1		



3.3 Safety and accessibility in use (BWR 4)

Basic requirement for construction works 4: Safety and accessibility in use						
Essential characteristic	Clause EAD	Performance				
Bond strength between base coat and insulation product.(minimum / mean value)(kPa)	2.2.11.1	Thermal insulation	Initial state	After hydrothermal cycles	After 7 days' water immersion (on samples)	
		EPS	150 / 200 ≥ 80	100 / 137 ≥ 80	-----	
		XPS	340 / 360 ≥ 80	340 / 360 ≥ 80 (on samples)	-----	
		MW	18 / 20	7 / 9	-----	
The breakage location was 100% on the insulation board MW and EPS, on XPS was adhesive between the insulation and the base coat.						
Bond strength between adhesive and substrate (minimum /mean value) (kPa)	2.2.11.2	Initial state		Immersion 48 h and 2 h drying	Immersion 48 h and 7 d drying	
		1400 / 1600 ≥ 250		1400 / 1550 ≥ 80	1400 / 1520 ≥ 250	
Bond strength between adhesive and insulation (minimum /mean value) (kPa)	2.2.11.3	Thermal insulation	Initial state	Immersion 48 h and 2 h drying	Immersion 48 h and 7 d drying	
		EPS	150 / 200 ≥ 80	170 / 190 ≥ 30	200 / 230 ≥ 80	
		XPS	320 / 380 ≥ 80	190 / 235 ≥ 30	280 / 300 ≥ 30	
		MW	18 / 20	12 / 14	12 / 15	
The breakage location was 100 % on the insulation board MW and EPS, on XPS was adhesive between the insulation and the base coat.						
Fixing strength (transverse displacement test)	2.2.12	The test is not required since mechanically fixed ETICS with supplementary adhesive, where the bonded area exceeds 20 %.				
Pull-through test of fixings. (minimum / mean value) (kN/fixing)	2.2.13.1	In the middle of Tector NATURTHERM PANEL MW of 6 cm with TR ≥ 7,5 (Rpanel) These test results limited to insulation with TR ≥ 7.5				
		Dry condition (Center)		Wet condition (Center)		
		0.23 / 0.26		0.18 / 0.24		
Tensile perpendicular to the faces of thermal insulation	2.2.14.1	Tector NATURTHERM PANEL EPS: EN 1607, TR = 100 kPa				
		Tector NATURTHERM PANEL XPS: EN 1607, TR = 200 kPa				
		Tector NATURTHERM PANEL MW: EN 1607, TR = 7.5 kPa				
Shear strength / shear modulus of elasticity th.Insulation	2.2.15	Tector NATURTHERM PANEL EPS: EN 12090: Shear strength(kPa): 75; Shear modulus (kPa):1000				
		Tector NATURTHERM PANEL XPS: EN 12090: Shear strength(kPa): 150; Shear modulus (kPa):1000				
Rendering strip tensile test: base coat	2.2.17	NPA				
Bond strength after ageing (minimum / mean value) (kPa)	2.2.20	Rendering		EPS	XPS	
		Naturcolor Fondo + Naturmortar Acrílico		150 / 174	340 / 360	
				8 / 9		
The breakage location was 100% on the insulation board MW and EPS, on XPS was adhesive between the insulation and the base coat.						
Mechanical and physical characteristics of the mesh	2.2.21	Status		Warp	Weft	
		Initial / After ageing (N/ mm)		44 / 22	45 / 25	
		Deference (%)		≤ 50		
		Elongation after ageing (%)		≤ 4		

3.4 Energy economy and heat retention (BWR 6)

Basic requirement for construction works 6: Energy economy and heat retention		
Essential characteristic	Relevant clause in EAD	Performance
Thermal resistance thermal transmittance	2.2.23.1	Tector NATURTHERM PANEL EPS $\lambda_D = 0,037$ W/mK
		Tector NATURTHERM PANEL XPS $\lambda_D = 0.034 - 0.036$ W/mK
		Tector NATURTHERM PANEL MW $\lambda_D = 0.035$ W/mK



The additional thermal resistance provided by the ETICS (R_{ETICS}) to the substrate wall is calculated from the thermal resistance of the thermal insulation product ($R_{insulation}$), determined in accordance with 2.2.23.1, and from either the tabulated R render value of the render system (R_{render} is about $0.02 \text{ m}^2\text{K/W}$) or R_{render} determined by test according to EN 12667 or EN 12664 (depending on expected thermal resistance).

$$R_{ETICS} = R_{insulation} + R_{render} \text{ [(m}^2\text{K)/W]}$$

as described in EN ISO 10456.

The thermal bridges caused by mechanical fixing devices influence the thermal transmittance of the entire wall and shall be taken into account using the following calculation:

$$U_c = U + \Delta U \text{ [W/(m}^2\text{K)]}$$

With: U_c corrected thermal transmittance of the entire wall, including thermal bridges
 U thermal transmittance of the entire wall, including ETICS, without thermal bridges

$$U = \frac{1}{R_{ETICS} + R_{substrate} + R_{se} + R_{si}}$$

- $R_{substrate}$ thermal resistance of the substrate wall [(m²K)/W]
- R_{se} external surface thermal resistance [(m²K)/W]
- R_{si} internal surface thermal resistance [(m²K)/W]
- ΔU correction term of the thermal transmittance for mechanical fixing devices
 = $\chi_p \cdot n$ (for anchors) + $\sum \psi_i \cdot \ell_i$ (for profiles) (formula x)
- χ_p point thermal transmittance value of the anchor [W/K]. If not specified in ETA for anchors, the following values apply:
 = 0.002 W/K for anchors with a plastic screw/nail, stainless steel screw/nail with the head covered by at least 15 mm plastic material, or with a minimum 15 mm air gap at the head of the screw/nail.
 = 0.004 W/K for anchors with a galvanized carbon steel screw/nail with the head covered by at least 15 mm a plastic material or a minimum 15 mm air gap at the head of the screw/nail.
 = 0.008 W/K for all other anchors (worst case)
- n number of anchors per m². In case n is more than 16, the formula (x) is not applied.
- ψ_i linear thermal transmittance value of the profile [W/(m·K)]
- ℓ_i length of the profile per m².

The influence of thermal bridges can also be calculated as described in EN ISO 10211.
 It shall be calculated according to this standard if there are more than 16 anchors per m² foreseen. The declared χ_p -values do not apply in this case.

4 Assessment and verification of constancy of performance (hereinafter AVCP) system applied, with reference to its legal base

According to the decision 97/556/EC of the European Commission amended by 2001/596/EC, a system 2+ of assessment and verification of constancy of performance (see EC delegated regulation (EU) No 568/2014 amending Annex V to Regulation (EU) N° 305/2011) applies.

Product	Intended uses	Level or Classes	System
TECTOR NATURTHERM	External Thermal Insulation Composite System with rendering for use on building walls	Any	2+

This system of attestation of conformity +2 is defined as follows:

Tasks for the manufacturer: Initial type-testing of the product, Factory production control and Testing of samples taken at the factory in accordance with a prescribed test plan.

- Tasks for the notified body: Certification of factory production control on the basis of:
- Initial inspection of factory and of factory production control.
 - Continuous surveillance (annual), assessment and assessment of factory production control.



5 Technical details necessary for the implementation of the AVCP system, as provided for in the applicable EAD

Technical details necessary for the implementation of the AVCP system are laid down in the control plan which is deposited at IETcc⁽³⁾.

5.1 Tasks of the manufacturer

Factory production control. The manufacturer shall exercise permanent internal control of production. All the elements, requirements and provisions adopted by the manufacturer shall be documented in a systematic manner in the form of written policies and procedures, including records of results performed. This production control system shall ensure that the product is in conformity with this ETA.

The manufacturer may only use components stated in the technical documentation of this ETA including Control Plan. The incoming raw materials are subjected to verifications by the manufacturer before acceptance.

The factory production control shall be in accordance with the Control Plan. The results of factory production control shall be recorded and evaluated in accordance with the provisions of the Control Plan.

For the components of the ETICS, which the manufacturer does not manufacture by himself, he shall make sure that factory production control carried out by the other manufacturers gives the guarantee of the components compliance with the ETA.

Initial type-testing of the product. The initial type-testing have been conducted by the IETcc to issued this ETA in accordance with the EAD 040083-00-0404 "External thermal insulation composite systems (ETICS) with renderings". The verifications underlying this ETA have been furnished on samples from the current production.

Other tasks of the manufacturer. The manufacturer shall, on the basis of a contract, involve a body which is notified for the tasks referred to in section 4 in order to undertake the actions laid down in this clause. For this purpose, the control plan shall be handed over by the manufacturer to the notified bodies involved.

The manufacturer shall make a declaration of conformity, stating that the construction product is in conformity with the provisions of this ETA.

5.2 Tasks of notified bodies.

Initial inspection of factory and of factory production control. The Notified Body shall ascertain that, in accordance with the Control Plan, the factory (in particular the employees and the equipment) and the factory production control are suitable to ensure continuous and orderly manufacturing of the components according to the specifications mentioned in clause 2 of this ETA.

Continuous surveillance, assessment and assessment of factory production control, in accordance with the provisions laid down in the control plan, at least one per year.

The notified body shall retain the essential points of its actions referred to above and state the results obtained and conclusions drawn in a written report. The notified certification body involved by the manufacturer shall issue an EC Certificate of factory production control stating the conformity of the provisions of this ETA.

In cases where the provisions of the ETA and its control plan are no longer fulfilled the notified certification body shall withdraw the certificate of conformity and inform to IETcc without delay.

Issued in Madrid on 15 of February 2023

D. Ángel Castillo Talavera

Director

on behalf of Instituto de Ciencias de la Construcción Eduardo Torroja (IETcc – CSIC)

⁽³⁾ The Control Plan is a confidential part of the ETA and only handed over to the notified certification body involved in the assessment and verification of constancy of performance.



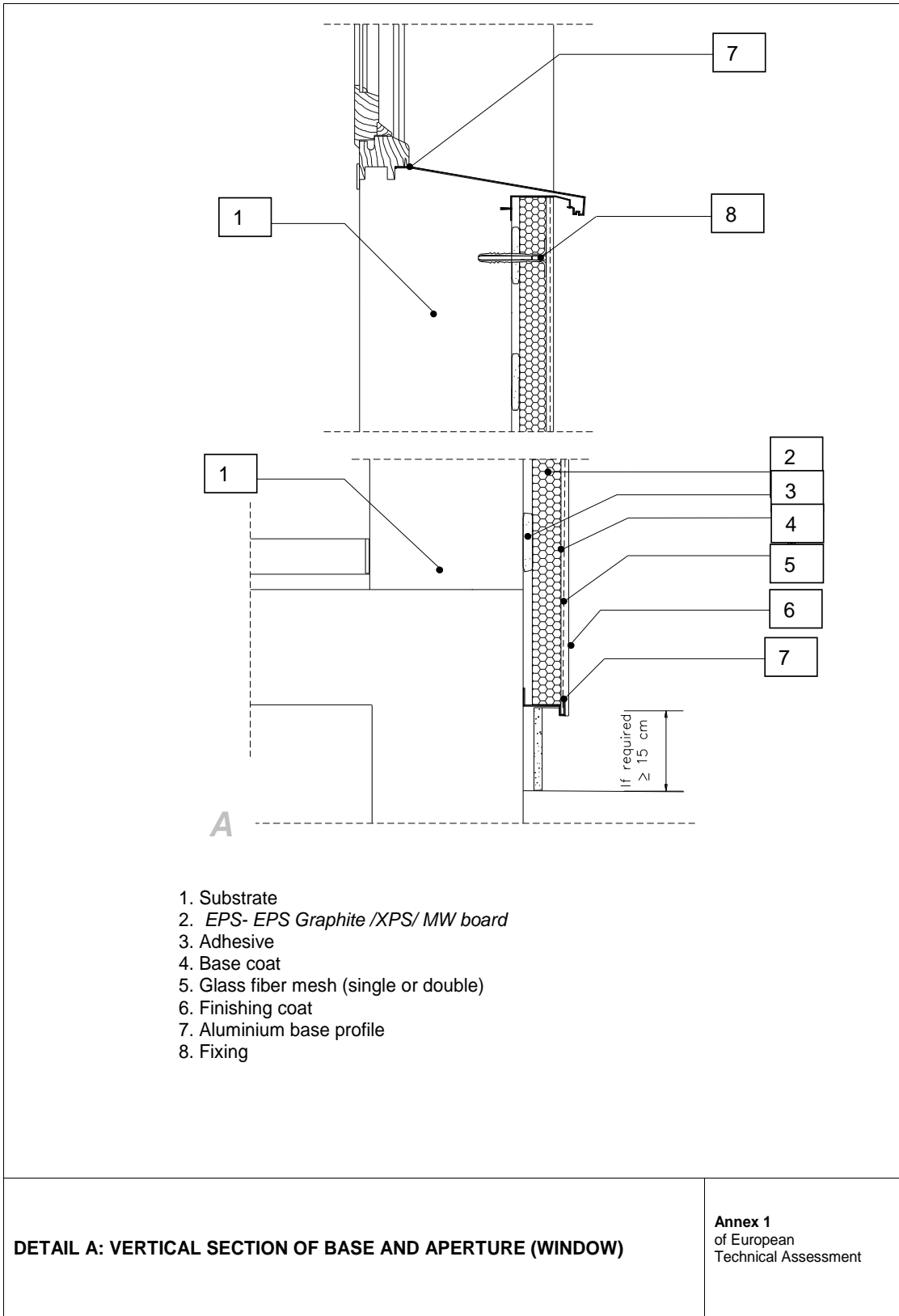

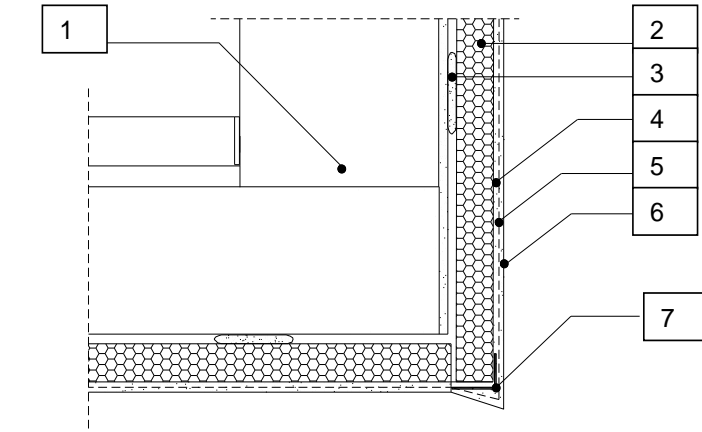

B

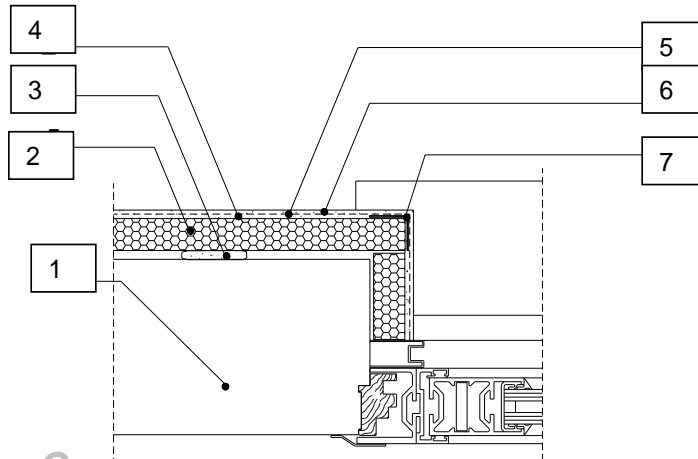

C

1. Substrate
2. EPS- EPS Graphite /XPS / MW boards
3. Adhesive
4. Base coat
5. Glass fiber mesh (single or double)
6. Finishing coat
7. Aluminium corner profile

DETAIL B: VERTICAL SECTION OF APERTURE (WINDOW)
DETAIL C: HORIZONTAL SECTION OF APERTURE (WINDOW)

Annex 2
of European
Technical Assessment

