

**INSTITUTO DE CIENCIAS  
DE LA CONSTRUCCIÓN  
EDUARDO TORROJA**

C/ Serrano Galvache n. 4 28033 Madrid (Spain)  
Tel.: (34) 91 302 04 40 Fax: (34) 91 302 07 00  
[direccion.ietcc@csic.es](mailto:direccion.ietcc@csic.es) [www.ietcc.csic.es](http://www.ietcc.csic.es)

## European Technical Assessment

**ETA 18/0609  
of 10/09/2018**

English translation prepared by IETcc. Original version in Spanish language

### General Part

**Technical Assessment Body issuing the ETA designated according to Art. 29 of Regulation (EU) 305/2011:**

Instituto de Ciencias de la Construcción Eduardo Torroja (IETcc)

**Trade name of the construction product**

**TRSO / TRSOK drop in anchor**

**Product family to which the construction product belongs**

Deformation controlled anchor made of galvanized steel of sizes M6, M8, M10, M12, M16 and M20 for use in non-cracked concrete

**Manufacturer**

**BSK Technika Zamocowań Sp. z o.o.**  
Dulęby 10  
40-833 Katowice, Poland.  
website: [www.bsk-technikazamocowan.pl](http://www.bsk-technikazamocowan.pl)

**Manufacturing plants**

ETA holder plant 1

**This European Technical Assessment contains**

10 pages including 3 annexes which form an integral part of this assessment.

**This European Technical Assessment is issued in accordance with regulation (EU) No 305/2011, on the basis of**

European Technical Assessment EAD 330232-00-0601 "Mechanical Fasteners for use in concrete", ed. October 2016

*English translation prepared by IETcc*

This European Technical Assessment is issued by the Technical Assessment Body in its official language. Translations of this European Technical Assessment in other languages shall fully correspond to the original issued document and should be identified as such.

This European Technical Assessment may be withdrawn by the issuing Technical Assessment Body, in particular pursuant to information by the Commission according to article 25 (3) of Regulation (EU) No 305/2011.

## SPECIFIC PART

### 1. Technical description of the product

The BSK TRSO / TRSOK in the range of M6 to M20 is an anchor made of galvanised steel, which is placed into a drilled hole and anchored by deformation-controlled expansion. The anchorage is characterised by friction between the sleeve and concrete.

Product and product description is given in annex A.

### 2. Specification of the intended use in accordance with the applicable European Assessment Document.

The performances given in section 3 are only valid if the anchor is used in compliance with the specifications and conditions given in annex B.

The verifications and assessment methods on which this European Technical Assessment is based lead to the assumption of a working life of the anchor of at least 50 years. The indications given on the working life cannot be interpreted as a guarantee given by the producer, but are to be regarded only as a mean to choosing the right products in relation to the expected economically reasonable working life of the works.

### 3. Performance of the product and references to the methods used for its assessment

#### 3.1 Mechanical resistance and stability (BWR 1)

Essential characteristic	Performance
Characteristic resistance under static or quasi static loading	See annexes C1 to C3
Displacements under tension and shear loads	See annexes C2 and C3

#### 3.2 Safety in case of fire (BWR 2)

Essential characteristic	Performance
Reaction to fire	Anchorage satisfies requirements for class A1

#### 3.3 Hygiene, health and the environment (BWR 3)

This requirement is not relevant for the anchors.

#### 3.4 Safety in use (BWR 4)

The essential characteristics regarding safety in use are included under the basic works requirements Mechanical resistance and stability.

#### 3.5 Protection against noise (BWR 5)

This requirement is not relevant for the anchors.

English translation prepared by IETcc

### **3.6 Energy economy and heat retention (BWR 6)**

This requirement is not relevant for the anchors.

### **3.7 Sustainable use of natural resources (BWR 7)**

No performance determined

## **4. Assessment and Verification of Constancy of Performances (hereinafter AVCP) system applied, with reference to its legal base**

The applicable European legal act for the system of Assessment and Verification of Constancy of Performances (see annex V to Regulation (EU) No 305/2011) is 96/582/EC.

The system to be applied is 1.

## **5. Technical details necessary for the implementation of the AVCP system, as provided for in the applicable European Assessment Document.**

The technical details necessary for the implementation of the AVCP system are laid down in the quality plan deposited at Instituto de Ciencias de la Construcción Eduardo Torroja.



Instituto de Ciencias de la Construcción Eduardo Torroja  
CONSEJO SUPERIOR DE INVESTIGACIONES CIENTÍFICAS

C/ Serrano Galvache n.º 4. 28033 Madrid.  
Tel: (+34) 91 302 04 40 Fax: (+34) 91 302 07 00  
[www.ietcc.csic.es](http://www.ietcc.csic.es)



On behalf of the Instituto de Ciencias de la Construcción Eduardo Torroja  
Madrid, 10<sup>th</sup> of September 2018

Angel Castillo Talavera  
Director

**Product**

**TRSO, TRSOK anchor**



**TRSO anchor**



**TRSOK anchor**

Identification on sleeve: “TRSO (TRSOK)” + Metric; e.g: TRSO M10

Anchor dimensions		M6	M8	M10	M12	M16	M20
ØD: External diameter	[mm]	8	10	12	15	20	25
Ød: internal diameter	[mm]	M6	M8	M10	M12	M16	M20
L: total length	[mm]	25	30	40	50	65	80

**Setting tool**



Setting tool dimensions		M6	M8	M10	M12	M16	M20
Ø D <sub>1</sub>	[mm]	7,5	9,5	11,5	14,5	18,0	22,0
Ø D <sub>2</sub>	[mm]	5,0	6,5	8,0	10,2	13,5	16,5
L <sub>s</sub>	[mm]	15	18	24	30	36	50

Setting tool could be assembled with a plastic handle for hand protection purposes

TRSO, TRSOK anchor	<b>Annex A1</b>
Product description	
Product	

**Installed condition**

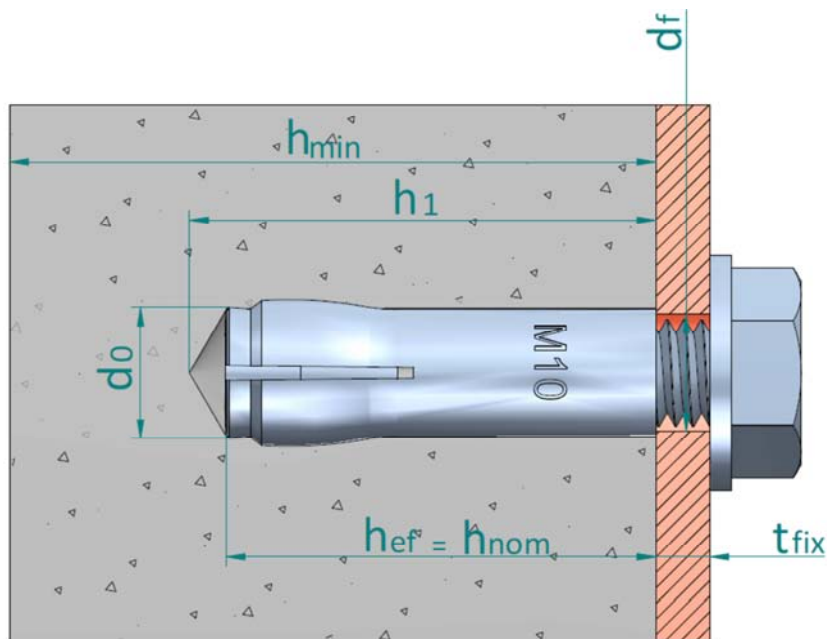

- $h_{ef}$ : Effective anchorage depth
- $h_1$ : Depth of drilled hole
- $h_{nom}$ : Overall anchor embedment depth in the concrete
- $h_{min}$ : Minimum thickness of concrete member
- $t_{fix}$ : Thickness of fixture
- $d_0$ : Nominal diameter of drill bit
- $d_f$ : Fixture clearance hole diameter

**Table A1: materials**

Item	Designation	Material for TRSO / TRSOK
1	Sleeve	Carbon steel wire rod, zinc plated $\geq 5 \mu\text{m}$ ISO 4042 A2
2	Cone	Carbon steel wire rod, zinc plated $\geq 5 \mu\text{m}$ ISO 4042 A2
3	Plastic retainer	PVC

TRSO, TRSOK anchor

Product description

Installed condition and Materials

**Annex A2**

### **Specifications of intended use**

#### **Anchorage subjected to:**

- Static or quasi static loads

#### **Base materials:**

- Reinforced or unreinforced normal weight concrete according to EN 206-1:2008
- Strength classes C20/25 to C50/60 according to EN 206-1:2008
- Uncracked concrete

#### **Use conditions (environmental conditions):**

- Anchorages subjected to dry internal conditions.

#### **Design:**

- Anchorages are designed under the responsibility of an engineer experienced in anchorages and concrete.
- Verifiable calculation rules and drawings are prepared taking into account of the loads to be anchored. The position of the anchor is indicated on the design drawings (e.g. position of the anchor relative to reinforcement or to supports, etc.).
- Anchorages under static or quasi-static actions are designed for design method A in accordance with:
  - ETAG 001, Annex C, edition August 2010
  - EN 1992-4:2018

#### **Installation:**

- Hole drilling by rotary plus hammer mode.
- Anchor installation carried out by appropriately qualified personal and under the supervision of the person responsible for technical matters of the site.
- In case of aborted hole: new drilling at a minimum distance away of twice the depth of aborted hole or smaller distance if the aborted hole is filled with high strength mortar and if under shear or oblique tension load it is not the direction of the load application.
- The bolt or threaded rod to be used shall be property class 4.6 / 5.6 / 5.8 / 6.8 or 8.8 according to ISO 898-1.
- The length of the bolt shall be determined as:
  - Minimum bolt length =  $t_{fix} + l_{s,min}$
  - Maximum bolt length =  $t_{fix} + l_{s,max}$

<b>TRSO, TRSOK anchor</b>	<b>Annex B1</b>
<b>Intended use</b>	
Specifications	

**Table C1: Installation parameters for TRSO, TRSOK anchor**

Installation parameters			Performances					
			M6	M8	M10	M12	M16	M20
$d_o$	Nominal diameter of drill bit:	[mm]	8	10	12	15	20	25
D	Thread diameter:	[mm]	M6	M8	M10	M12	M16	M20
$d_f$	Fixture clearance hole diameter $\leq$	[mm]	7	9	12	14	18	22
$T_{inst}$	Maximum installation torque:	[Nm]	4	11	17	38	60	100
$l_{s,min}$	Minimum screwing depth:	[mm]	6	8	10	12	16	20
$l_{s,max}$	Maximum screwing depth:	[mm]	10	13	17	21	27	34
$h_{min}$	Minimum thickness of concrete member:	[mm]	100	100	100	100	130	160
$h_1$	Depth of drilled hole:	[mm]	27	33	43	54	70	86
$h_{nom}$	Overall anchor embedm. depth in the concrete:	[mm]	25	30	40	50	65	80
$h_{ef}$	Effective anchorage depth:	[mm]	25	30	40	50	65	80
$s_{min}$	Minimum allowable spacing:	[mm]	60	60	80	100	130	160
$c_{min}$	Minimum allowable distance:	[mm]	105	105	140	175	230	280

**Installation process**

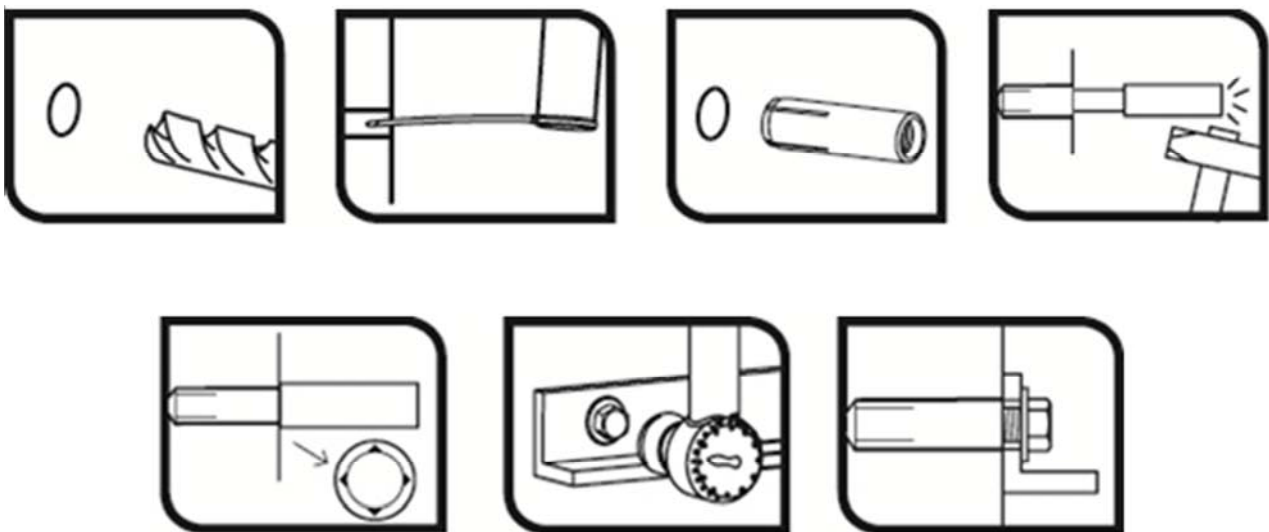

TRSO, TRSOK anchor

Performances

Installation parameters and installation procedure

Annex C1



**Table C2: Characteristic values to tension loads of design method A according to ETAG 001 Annex C or EN 1992-4 for TRSO, TRSOK anchor**

Characteristic values of resistance to tension loads of design according to design method A			Performances						
			M6	M8	M10	M12	M16	M20	
<b>Tension loads: steel failure</b>									
$N_{Rk,s}$	Tension steel char. resistance, steel class 4.6:	[kN]	8,0	14,6	23,2	33,7	62,8	98,0	
$\gamma_{Ms}$	Partial safety factor:	[-]	2,0	2,0	2,0	2,0	2,0	2,0	
$N_{Rk,s}$	Tension steel char. resistance, steel class 4.8:	[kN]	8,0	14,6	18,2	33,7	62,8	95,1	
$\gamma_{Ms}$	Partial safety factor:	[-]	1,5	1,5	1,5	1,5	1,5	1,5	
$N_{Rk,s}$	Tension steel char. resistance, steel class 5.6:	[kN]	10,1	18,3	18,2	42,2	78,5	122,5	
$\gamma_{Ms}$	Partial safety factor:	[-]	2,0	2,0	1,5	2,0	2,0	2,0	
$N_{Rk,s}$	Tension steel char. resistance, steel class 5.8:	[kN]	10,1	17,6	18,2	35,1	65,0	95,1	
$\gamma_{Ms}$	Partial safety factor:	[-]	1,5	1,5	1,5	1,5	1,5	1,5	
$N_{Rk,s}$	Tension steel char. resistance, steel class 6.8	[kN]	12,1	17,6	18,2	35,1	65,0	95,1	
$\gamma_{Ms}$	Partial safety factor:	[-]	1,5	1,5	1,5	1,5	1,5	1,5	
$N_{Rk,s}$	Tension steel char. resistance, steel class 8.8	[kN]	13,1	17,6	18,2	35,1	65,0	95,1	
$\gamma_{Ms}$	Partial safety factor:	[-]	1,5	1,5	1,5	1,5	1,5	1,5	
<b>Tension loads: pull-out failure in concrete</b>									
$N_{Rk,p,ucr}$	Tension characteristic resistance in C20/25 uncracked concrete:	[kN]	-- <sup>3)</sup>	-- <sup>3)</sup>	-- <sup>3)</sup>	-- <sup>3)</sup>	-- <sup>3)</sup>	-- <sup>3)</sup>	
$\Psi_c$	Increasing factor for $N_{Rk,p}^0$ :	C30/37	[-]	1,02	1,22	1,15	1,15	1,22	1,19
		C40/50	[-]	1,04	1,41	1,29	1,28	1,41	1,35
		C50/60	[-]	1,05	1,55	1,37	1,37	1,55	1,46
$\gamma_{ins}^{1)}$ $\gamma_2^{2)}$	Installation safety factor:	[-]	1,2	1,2	1,4	1,4	1,4	1,4	
<b>Tension loads: concrete cone and splitting failure</b>									
$h_{ef}$	Effective embedment depth:	[mm]	25	30	40	50	65	80	
$k_{ucr,N}^{1)}$	Factor for uncracked concrete:	[-]	11.0						
$k_{ucr,N}^{2)}$	Factor for uncracked concrete:	[-]	10.1						
$\gamma_{ins}^{1)}$ $\gamma_2^{2)}$	Installation safety factor:	[-]	1,2	1,2	1,4	1,4	1,4	1,4	
$S_{cr,N}$	Concrete cone failure:	[mm]	3 x $h_{ef}$						
$C_{cr,N}$		[mm]	1.5 x $h_{ef}$						
$S_{cr,sp}$	Splitting failure:	[mm]	150	180	240	300	390	480	
$C_{cr,sp}$		[mm]	75	90	120	150	195	240	
<b>Displacements under tension loads</b>									
$N$	Service tension load in uncracked concrete C20/25 to C50/60:	[kN]	2,4	3,4	6,0	7,4	17,8	18,2	
$\bar{\delta}_{N0}$	Short term displacement under tension loads:	[mm]	0,1	0,1	0,1	0,1	0,1	0,1	
$\bar{\delta}_{N\infty}$	Long term displacement under tension loads:	[mm]	0,3	0,3	0,3	0,3	0,3	0,3	

<sup>1)</sup> Parameter relevant only for design according to EN 1992-4:2018

<sup>2)</sup> Parameter relevant only for design according to ETAG 001, Annex C

<sup>3)</sup> Pull out failure does not govern

TRSO, TRSOK anchor

Performances

Characteristic values for tension loads

Annex C2

**Table C3: Characteristic values to shear loads of design method A according to ETAG 001 Annex C or EN 1992-4 for TRSO, TRSOK anchor**

Characteristic values of resistance to shear loads of design according to design method A			Performances						
			M6	M8	M10	M12	M16	M20	
<b>Shear loads: steel failure without lever arm</b>									
$V_{Rk,s}$	Shear steel char. resistance, steel class 4.6:	[kN]	4,0	7,3	11,6	16,8	31,4	49,0	
$\gamma_{Ms}$	Partial safety factor:	[-]	1,67	1,67	1,67	1,67	1,67	1,67	
$V_{Rk,s}$	Shear steel char. resistance, steel class 4.8:	[kN]	4,0	7,3	9,1	16,8	31,4	47,5	
$\gamma_{Ms}$	Partial safety factor:	[-]	1,25	1,25	1,25	1,25	1,25	1,25	
$V_{Rk,s}$	Shear steel char. resistance, steel class 5.6	[kN]	5,0	9,1	9,1	21,1	39,2	61,2	
$\gamma_{Ms}$	Partial safety factor:	[-]	1,67	1,67	1,25	1,67	1,67	1,67	
$V_{Rk,s}$	Shear steel char. resistance, steel class 5.8	[kN]	5,0	8,8	9,1	17,5	32,5	47,5	
$\gamma_{Ms}$	Partial safety factor:	[-]	1,25	1,25	1,25	1,25	1,25	1,25	
$V_{Rk,s}$	Shear steel char. resistance, steel class 6.8	[kN]	6,0	8,8	9,1	17,5	32,5	47,5	
$\gamma_{Ms}$	Partial safety factor:	[-]	1,25	1,25	1,25	1,25	1,25	1,25	
$V_{Rk,s}$	Shear steel char. resistance, steel class 8.8:	[kN]	6,5	8,8	9,1	17,5	32,5	47,5	
$\gamma_{Ms}$	Partial safety factor:	[-]	1,25	1,25	1,25	1,25	1,25	1,25	
<b>Shear loads: steel failure with lever arm</b>									
$M_{Rk,s}^0$	Characteristic bending moment, steel class 4.6	[Nm]	6,1	15,0	29,9	52,4	133,3	259,8	
$\gamma_{Ms}$	Partial safety factor:	[-]	1,67	1,67	1,67	1,67	1,67	1,67	
$M_{Rk,s}^0$	Characteristic bending moment, steel class 4.8	[Nm]	6,1	15,0	29,9	52,4	133,3	259,8	
$\gamma_{Ms}$	Partial safety factor:	[-]	1,25	1,25	1,25	1,25	1,25	1,25	
$M_{Rk,s}^0$	Characteristic bending moment, steel class 5.6	[Nm]	7,6	18,8	37,4	65,5	166,6	324,8	
$\gamma_{Ms}$	Partial safety factor:	[-]	1,67	1,67	1,67	1,67	1,67	1,67	
$M_{Rk,s}^0$	Characteristic bending moment, steel class 5.8	[Nm]	7,6	18,8	37,4	65,5	166,6	324,8	
$\gamma_{Ms}$	Partial safety factor:	[-]	1,25	1,25	1,25	1,25	1,25	1,25	
$M_{Rk,s}^0$	Characteristic bending moment, steel class 6.8	[Nm]	9,2	22,5	44,9	78,7	199,9	389,7	
$\gamma_{Ms}$	Partial safety factor:	[-]	1,25	1,25	1,25	1,25	1,25	1,25	
$M_{Rk,s}^0$	Characteristic bending moment, steel class 8.8	[Nm]	12,2	30,0	59,9	104,9	266,6	519,7	
$\gamma_{Ms}$	Partial safety factor: <sup>1)</sup>	[-]	1,25	1,25	1,25	1,25	1,25	1,25	
<b>Shear loads: concrete pryout failure</b>									
$k_s^{(1)}$ $k^{(2)}$	k factor:	[-]	1,0	1,0	1,0	1,0	2,0	2,0	
$\gamma_{ins}^{(1)}$ $\gamma_2^{(2)}$	Installation safety factor:	[-]	1,0						
<b>Shear loads: concrete edge failure</b>									
$l_f$	Effective anchorage depth under shear loads:	[mm]	25	30	40	50	65	80	
$d_{nom}$	Outside anchor diameter:	[mm]	8	10	12	15	20	25	
$\gamma_{ins}^{(1)}$ $\gamma_2^{(2)}$	Installation safety factor:	[-]	1,0						
<b>Displacements under shear loads</b>									
V	Service shear load in uncracked concrete C20/25 to C50/60:	[kN]	3,8	5,0	5,2	10,1	18,6	27,2	
$\bar{\delta}_{V0}$	Short term displacement under shear loads:	[mm]	2,4	2,4	2,4	1,3	1,0	1,0	
$\bar{\delta}_{V\infty}$	Long term displacement under shear loads:	[mm]	3,5	3,5	3,5	2,0	1,5	1,5	

<sup>1)</sup> Parameter relevant only for design according to EN 1992-4:2018

<sup>2)</sup> Parameter relevant only for design according to ETAG 001, Annex C

TRSO, TRSOK anchor

Performances

Characteristic values for shear load.

Annex C3