

**INSTITUTO DE CIENCIAS
DE LA CONSTRUCCIÓN
EDUARDO TORROJA**

C/ Serrano Galvache n. 4 28033 Madrid (Spain)
Tel.: (34) 91 302 04 40 Fax: (34) 91 302 07 00
direccion.ietcc@csic.es <https://dit.ietcc.csic.es>

European Technical Assessment

ETA 18/0386 of 13/02/2019

English translation prepared by IETcc. Original version in Spanish language

General Part

Technical Assessment Body issuing the ETA designated according to Art. 29 of Regulation (EU) 305/2011

Instituto de Ciencias de la Construcción Eduardo Torroja (IETcc)

Trade name of the construction product

TEX screws: TEX-ZT, TEX-ZP, TEX-BT, TEX-BP, TECBT, TXAB

Product family to which the construction product belongs

Screws for use in timber constructions of diameters 6, 8 and 10

Manufacturer

Index - Técnicas Expansivas S.L.
Segador 13
26006 Logroño (La Rioja) Spain.
website: www.indexfix.com

Manufacturing plants

Index plant 11

This European Technical Assessment contains

17 pages including 4 annexes which form an integral part of this assessment.

This European Technical Assessment is issued in accordance with regulation (EU) No 305/2011, on the basis of

European Assessment Document EAD 130118-00-0603 "Screws for use in timber constructions".
Ed. October 2016

English translation prepared by IETcc

This European Technical Assessment is issued by the Technical Assessment Body in its official language. Translations of this European Technical Assessment in other languages shall fully correspond to the original issued document and should be identified as such.

This European Technical Assessment may be withdrawn by the issuing Technical Assessment Body, in particular pursuant to information by the Commission according to article 25 (3) of Regulation (EU) No 305/2011.

SPECIFIC PART

1. Technical description of the product

The Index TEX screws of diameters 6, 8 and 10 are screws made of hardened carbon steel with a corrosion protection according to annex B and an antifriction coating. The overall length of the screw is ranging from 40 to 450 mm. Further dimensions are shown in annex D.

The washers are made of carbon steel. The dimensions of the washers are shown in annex D.

2. Specification of the intended use in accordance with the applicable European Assessment Document.

The performances given in section 3 are only valid if the screws are used in compliance with the specifications and conditions given in annex A. Durability is only ensured if the specification of the intended use according to annex A is taken into account. The verifications and assessment methods on which this European Technical Assessment is based lead to the assumption of a working life of the anchor of at least 50 years. The indications given on the working life cannot be interpreted as a guarantee given by the producer, but are to be regarded only as a mean to choosing the right products in relation to the expected economically reasonable working life of the works.

3. Performance of the product and references to the methods used for its assessment

- **Mechanical resistance and stability (BWR 1)**

Essential characteristic	Performance
1. Dimensions	See annex D
2. Characteristic yield moment	See annex B
3. Bending angle	See annex B
4. Characteristic withdrawal parameter	See annex B
5. Characteristic head pull-through parameter	See annex B
6. Characteristic tensile strength	See annex B
7. Characteristic yield strength	See annex B
8. Characteristic torsional strength	See annex B
9. Insertion moment	See annex B
10. Spacing, end and edge distances of the screws and minimum thickness of the wood based material	See annex B
11. Slip modulus for mainly axially loaded screws	See annex B
12. Durability against corrosion	See annex B

- **Safety in case of fire (BWR 2)**

Essential characteristic	Performance
13. Reaction to fire	The screws are made of steel classified as Euroclass A1 in accordance with EC decision 96/603/EC, as amended by EC dec.2000/605/EC.

- **Safety in use (BWR 4)**

The essential characteristics regarding safety in use are included under the basic works requirement Mechanical Resistance and Stability.

English translation prepared by IETcc

4. Assessment and verification of constancy of performance (hereinafter AVCP) system applied, with reference to its legal base

The applicable European legal act for the system of Assessment and Verification of Constancy of Performances (see annex V of Regulation (EU) No 305/2011) is 1997/176/EC.

The system to be applied is 3.

5. Technical details necessary for the implementation of the AVCP system, as provided for in the applicable European Assessment Document.

The technical details necessary for the implementation of the AVCP system are laid down in the quality plan deposited at Instituto de Ciencias de la Construcción Eduardo Torroja.



Instituto de Ciencias de la Construcción Eduardo Torroja
CONSEJO SUPERIOR DE INVESTIGACIONES CIENTÍFICAS

C/ Serrano Galvache n.º 4. 28033 Madrid.
Tel: (+34) 91 302 04 40 Fax. (+34) 91 302 07 00

<https://dit.ietcc.csic.es>



On behalf of the Instituto de Ciencias de la Construcción Eduardo Torroja
Madrid, 13th of February 2019



Director IETcc-CSIC

SPECIFICATION OF INTENDED USE

Screws subjected to:

- Static and quasi-static loads

Base materials:

- The self-tapping screws are used for connections in load bearing timber structures between wood-based members or between those members and steel members:
 - Solid timber (softwood) according to EN 14081-1¹,
 - Glued laminated timber (softwood) according to EN 14080²,
 - Laminated veneer lumber LVL of softwood according to EN 14374³, arrangement of the screws only perpendicular to the plane of the veneers,
 - Glued solid timber (softwood) according to EN 14080 or national provisions that apply at the installation site,
 - Cross-laminated timber (softwood) according to European Technical Assessments or national provisions that apply at the installation site.
- The screws may be used for connecting the following wood-based panels to the timber members mentioned above:
 - Plywood according to EN 636⁴ and EN 13986⁵,
 - Oriented Strand Board, OSB according to EN 300⁶ and EN 13986,
 - Particleboard according to EN 312⁷ and EN 13986,
 - Fibreboards according to EN 622-2⁸, EN 622-3⁹ and EN 13986,
 - Cement-bonded particle boards according to EN 634-2¹⁰ and EN 13986,
 - Solid-wood panels according to EN 13353¹¹ and EN 13986.
- Wood-based panels shall only be arranged on the side of the screw head.
- Index TEX screws may be used for the fixing of thermal insulation material on top of rafters or on wood-based members in vertical façades according to annex C.

Use Conditions (environmental conditions):

- The corrosion protection of the Index TEX screws is specified in Annex B. With regards to the use and the environmental conditions, the national provisions of the place of installation apply.

Installation provisions

- EN 1995-1-1¹² in conjunction with the respective national annex applies for the installation.
- A minimum of two screws shall be used for connections in load bearing timber structures. This does not apply for special situations specified in National Annexes to EN 1995-1-1.
- The screws are driven into the wood-based member made of softwood without pre-drilling. The screw holes in steel members shall be pre-drilled with an adequate diameter greater than the outer thread diameter.
- If screws with an outer thread diameter $d \geq 8$ mm are driven into the wood-based member without pre-drilling, the structural solid or glued laminated timber, laminated veneer lumber and similar glued members shall be from spruce, pine or fir.
- Screws may be used with washers according to Annex D. After inserting the screw the washers shall touch the surface of the wood-based member completely.
- By fastening screws in wood-based members the head of the screws shall be flush with the surface of the wood based member.
- In the case of fastening battens on thermal insulation material on top of rafters the screws shall be driven in the rafter through the battens and the thermal insulation material without pre-drilling in one sequence.
- Maintenance and repair is not required during the assumed intended working life. Should repair prove necessary, it is normal to replace the screw.

TEX screws	Annex A1
Intended use	
Specifications	

English translation prepared by IETcc

- ¹ EN 14081-1:2016 Timber structures – Strength graded structural timber with rectangular cross section – Part 1: General requirements
- ² EN 14080:2013 Timber structures - Glued laminated timber and glued solid timber – Requirements
- ³ EN 14374:2004 Timber structures - Structural laminated veneer lumber - Requirements
- ⁴ EN 636:2012+A1:2015 Plywood – Specifications
- ⁵ EN 13986:2004+A1:2015 Wood-based panels for use in construction - Characteristics, evaluation of conformity and marking
- ⁶ EN 300:2006 Oriented strand boards (OSB) – Definition, classification and specifications
- ⁷ EN 312:2010 Particleboards - Specifications
- ⁸ EN 622-2:2004 Fibreboards – Specifications – Part 2: Requirements for hardboards
- ⁹ EN 622-3:2004 Fibreboards - Specifications - Part 3: Requirements for medium boards
- ¹⁰ EN 634-2:2007 Cement-bonded particleboards – Specifications – Part 2: Requirements for OPC bonded particleboards for use in dry, humid and external conditions
- ¹¹ EN 13353:2008+A1:2011 Solid wood panels (SWP) – Requirements
- ¹² EN 1995-1-1:2016 Eurocode 5. Design of timber structures. Part 1-1. General. Common rules for buildings

TEX screws	Annex A2
Intended use	
Specifications	

CHARACTERISTIC VALUES OF THE LOAD-CARRYING CAPACITY

Table B1. Characteristic load-carrying capacities of Index TEX screws

Outer thread diameter	[mm]	6.0	8.0	10.0
$M_{y,k}$: characteristic yield moment:	[Nm]	13.80	34.96	54.08
$f_{tens,k}$: characteristic tensile strength:	[kN]	13.72	25.20	36.09
$f_{tor,k}$: characteristic torsional strength:	[Nm]	12.39	30.26	51.20
$R_{tor,k}$: insertion moment:	[Nm]	2.63	6.86	9.62
bending angle:	[°]	27	22	18

General

The characteristic load-carrying capacity and the characteristic axial withdrawal capacity of Index TEX screws should be designed in accordance with EN 1995-1-1 or an appropriate national code.

The penetration length of the threaded part of the screw in the wood-based members l_{ef} shall be

$$l_{ef} \geq 4d / (\sin \alpha) \quad (B.1)$$

where

- α : angle between screw axis and grain direction
- d: outer thread diameter of the screw.

The outer thread diameter of screws inserted in cross-laminated timber shall be at least 6 mm. The inner thread diameter d_1 of the screws shall be greater than the maximal width of the gaps in the layer of cross laminated timber.

Laterally loaded screws

The characteristic load-carrying of index TEX screws shall be calculated according to EN 1995-1-1 using the outer diameter d as the nominal diameter of the screw. The contribution from the rope effect may be considered.

The embedding strength for the screws in wood-based members or in wood-based panels shall be taken from EN 1995-1-1 or from national provisions that apply at the installation site unless otherwise specified in the following.

Axial withdrawal capacity

The characteristic withdrawal parameter at an angle $\alpha = 90^\circ$ to the grain based on a characteristic density of the wood-based member of 350 kg/m³ is

- $f_{ax,k} = 11 \text{ N/mm}^2$ for screws with $6 \text{ mm} \leq d \leq 8 \text{ mm}$ and
- $f_{ax,k} = 10 \text{ N/mm}^2$ for screws with $d = 10 \text{ mm}$

For LVL a maximum characteristic density of 500 kg/m³ shall be used in equation (8.40a) of EN 1995-1-1.

TEX screws	Annex B1
Characteristic values of the load-carrying capacities	
General	

Head pull-through capacity

The characteristic value of the head pull-through parameter for Index TEX screws for a characteristic density of 380 kg/m³ of the timber and for wood-based panels like:

- Plywood according to EN 636 and EN 13986
- Oriented Strand Board, OSB according to EN 300 and EN 13986
- Particleboard according to EN 312 and EN 13986
- Fibreboards according to EN 622-2, EN 622-3 and EN 13986
- Cement-bonded particle boards according to EN 634-2 and EN 13986
- Solid-wood panels according to EN 13353 and EN 13986

with a thickness of more than 20 mm is

$$f_{head,k} = 10 \text{ N/mm}^2$$

For wood based panels with a thickness $12 \text{ mm} \leq t \leq 20 \text{ mm}$ the characteristic value of the head pull-through parameter for the screws is:

$$f_{head,k} = 8 \text{ N/mm}^2$$

For wood based panels with a thickness of less than 12 mm the characteristic head pull-through capacity for screws shall be based on a characteristic value of the head pull-through parameter of 8 N/mm², and limited to 400 N complying with the minimum thickness of the wood based panels of 1.2·d, with d as outer thread diameter and the values in Table B2.

Table B2 Minimum thickness of wood based panels

Wood based panel	Minimum thickness [mm]
Plywood	6
Fibreboards (hardboards and medium boards)	6
Oriented Strand Boards, OSB	8
Particleboards	8
Cement-bonded particle board	8
Solid wood panel	12

In steel-to-timber connections the head pull-through capacity is not governing.

Slip modulus

The axial slip modulus K_{ser} of the threaded part of a screw for the serviceability limit state shall be taken independent of angle α to the grain as:

$$K_{ser} = 780 \cdot d^{0.2} \cdot l_{ef}^{0.4} \text{ [N/mm]} \tag{B.2}$$

where

d: outer thread diameter of the screw [mm]

l_{ef} : penetration length of the threaded part of the screw in the wood-based member [mm].

TEX screws	Annex B2
Characteristic values of the load-carrying capacities	
Head pull-through capacity	

English translation prepared by IETcc

Spacing, end and edge distances of the screws and minimum thickness of the wood based material

Minimum thickness for structural members made from solid timber, glued laminated timber, glued solid timber, laminated veneer lumber and cross laminated timber is $t = 30$ mm for screws with $d \leq 8$ mm and $t = 40$ mm for screws with $d = 10$ mm.

For laterally and/or axially loaded screws

Screws in non pre-drilled holes.

For Index TEX screws minimum spacing and distances are given in EN 1995-1-1, clause 8.3.1.2 and Table 8.2 as for nails in non-predrilled holes.

Here, the outer thread diameter d shall be considered.

For only axially loaded screws

For index TEX screws the minimum spacings, end and edge distances are given in EN 1995-1-1, clause 8.3.1.2 and Table 8.2 as for nails in non-predrilled holes and clause 8.7.2, Table 8.6.

Durability against corrosion

Screws and washers made from carbon steel are electrogalvanised and yellow or blue chromate. The mean thickness of the zinc coating is $5 \mu\text{m}$.

TEX screws	Annex B3
Characteristic values of the load-carrying capacities	
Spacing, edge distances, minimum thickness and durability	

FASTENING OF THERMAL INSULATION MATERIAL ON TOP OF RAFTERS

General

Index TEX screws may be used for the fixing of thermal insulation material on top of rafters or on wood-based members in vertical façades. In the following, the meaning of the word rafter includes wood-based members with inclinations between 0° and 90°.

The thickness of the thermal insulation material may be up to 300 mm. The thermal insulation material shall be applicable as insulation on top of rafters or for façades according to national provisions that apply at the installation site.

The battens have to be from solid timber according to EN 338¹³ and/or to EN 14081-1¹⁴. The minimum thickness t and the minimum width b of the battens are given in table C1:

Table C1 Minimum thickness and minimum width of the battens

Outer thread diameter	Minimum thickness t	Minimum width b
[mm]	[mm]	[mm]
6	30	50
8	30	50
10	40	60

The angle α between the screw axis and the grain direction of the rafter should be between 30° and 90°. Instead of battens the wood-based panels specified in section *Mechanical model* may be used.

The minimum width of the rafters shall be 60 mm.

The spacing between screws shall be not more than 1.75 m.

Friction forces shall not be considered for the design of the characteristic axial load of the screws.

The anchorage of wind suction forces as well as the bending stresses of the battens shall be considered for design.

Screws perpendicular to the grain of the rafter (angle $\alpha = 90^\circ$) may be arranged where required considering the design of the battens.

Parallel inclined screws and thermal insulation material in compression

Mechanical model

The analysis of the fixing of the insulation and battens or boards, respectively, may be carried out using the static model of figure C1.

The system of rafter, thermal insulation material on top of rafter and counter battens parallel to the rafter may be considered as a beam on elastic foundation. The counter batten represents the beam, and the thermal insulation material on top of the rafter the elastic foundation. The minimum compressive stress of the thermal insulation material at 10% deformation, measured according to EN 826¹⁵, shall be $\sigma_{(10\%)} = 0.05 \text{ N/mm}^2$. The counter batten is loaded perpendicular to the axis by point loads F_b transferred by regularly spaced battens. Further point loads F_s are caused by the shear load of the roof due to dead and snow load, which are transferred from the screw heads into the counter battens.

¹³ EN 338:2016 Structural timber - Strength classes

¹⁴ EN 14081-1:2016 Timber structures - Strength graded structural timber with rectangular cross section - Part 1: General requirements

¹⁵ EN 826:2013 Thermal insulating products for building applications - Determination of compression behaviour

TEX screws

Fastening of thermal insulation material on top of rafters

General

Annex C1

English translation prepared by IETcc

Alternatively of battens the following wood-based panels may be used to cover the thermal insulation material if they are suitable for that use:

- Plywood according to EN 636 and EN 13986,
- Oriented Strand Board, OSB according to EN 300 and EN 13986,
- Particleboard according to EN 312 and EN 13986,
- Fibreboards according to EN 622-2, EN 622-3 and EN 13986.

The minimum thickness of the wood-based panels shall be 22 mm.

The word batten includes the meaning of wood-based panels in the following.

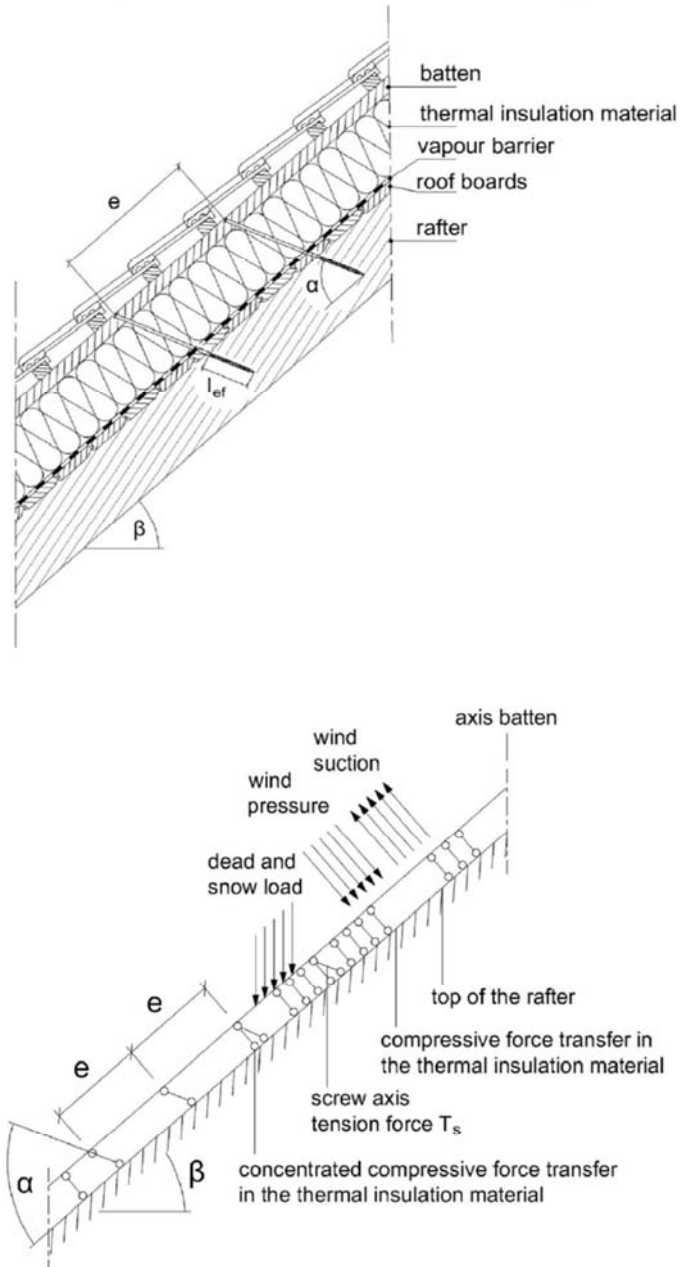

Figure C.1 Fastening of the thermal insulation material on top of rafters - structural system

TEX screws	Annex C2
Fastening of thermal insulation material on top of rafters	
Structural system	

Design of the battens

It's assumed that the spacing between the counter battens exceeds the characteristic length l_{char} .
The characteristic values of the bending stresses are calculated as:

$$M_k = \frac{(F_{b,k} + F_{s,k}) \cdot l_{char}}{4} \quad (C.1)$$

where

$$l_{char} = \sqrt[4]{\frac{4 \cdot EI}{w_{ef} \cdot K}} \quad (C.2)$$

l_{char} = characteristic length

EI = bending stiffness of the batten

K = coefficient of subgrade

w_{ef} = effective width of the thermal insulation material

$F_{b,k}$ = point loads perpendicular to the battens

$F_{s,k}$ = point loads perpendicular to the battens, load application in the area of the screw heads

The coefficient of subgrade K may be calculated from the modulus of elasticity E_{HI} and the thickness t_{HI} of the thermal insulation material if the effective width w_{ef} of the thermal insulation material under compression is known. Due to the load extension in the thermal insulation material the effective width w_{ef} is greater than the width of the batten or rafter, respectively. For further calculations, the effective width w_{ef} of the thermal insulation material may be determined according to:

$$w_{ef} = w + t_{HI} / 2 \quad (C.3)$$

where

w = minimum from width of the batten or rafter, respectively

t_{HI} = thickness of the thermal insulation material

$$K = E_{HI} / t_{HI} \quad (C.4)$$

The following condition shall be satisfied:

$$\frac{\sigma_{m,d}}{f_{m,d}} = \frac{M_d}{W \cdot f_{m,d}} \leq 1 \quad (C.5)$$

For the calculation of the section modulus W the net cross section shall be considered.
The characteristic values of the shear stresses shall be calculated according to:

$$V_k = \frac{(F_b + F_s)}{2} \quad (C.6)$$

The following condition need to be satisfied:

$$\frac{\tau_d}{f_{v,d}} = \frac{1.5 \cdot V_d}{A \cdot f_{v,d}} \leq 1 \quad (C.7)$$

For the calculation of the cross section area the net cross section shall be considered.

Design of the thermal insulation material

The characteristic value of the compressive stresses in the thermal insulation material shall be calculated according to:

$$\sigma_k = \frac{1.5 \cdot F_{b,k} + F_{s,k}}{2 \cdot l_{char} \cdot w} \quad (C.8)$$

The design value of the compressive stress shall not be greater than 110% of the compressive strength at 10% deformation calculated according to EN 826.

TEX screws

Fastening of thermal insulation material on top of rafters

Design of the battens and the thermal insulation material

Annex C3

Design of the screws

The screws are loaded predominantly axial. The characteristic value of the axial tension force in the screw may be calculated from the shear loads of the roof R_s :

$$T_{Sk} = \frac{R_{Sk}}{\cos \alpha} \quad (C.9)$$

The load-carrying capacity of axially loaded screws is the minimum design value of the axial withdrawal capacity of the threaded part of the screw, the head pull-through capacity of the screw and the tensile capacity of the screw according to Annex A.

In order to limit the deformation of the screw head for thermal insulation material with thickness over 220 mm or with compressive strength below 0.12 N/mm², respectively, the axial withdrawal capacity of the screws shall be reduced by the factors k_1 and k_2 :

$$F_{ax,\alpha,Rd} = \min \left\{ \frac{f_{ax,d} \cdot d \cdot l_{ef} \cdot k_1 \cdot k_2}{1.2 \cdot \cos^2 \alpha + \sin^2 \alpha} \cdot \left(\frac{\rho_k}{350} \right)^{0.8}; f_{head,d} \cdot d_h^2 \cdot \left(\frac{\rho_k}{350} \right)^{0.8}; \frac{f_{tens,k}}{\gamma_{M2}} \right\} \quad (C.10)$$

where:

$F_{ax,\alpha,Rd}$ design axial capacity of the screw at an angle α to the grain [N]

$f_{ax,d}$ design value of the axial withdrawal parameter of the threaded part of the screw [N/mm²]

d outer thread diameter of the screw [mm]

l_{ef} penetration length of the threaded part of the screw in the rafter [mm], $40 \text{ mm} \leq l_{ef} \leq 100 \text{ mm}$

ρ_k characteristic density of the wood-based member [kg/m³], for LVL the assumed characteristic density shall not exceed 500 kg/m³

α angle α between screw axis and grain direction, $30^\circ \leq \alpha \leq 90^\circ$

$f_{head,d}$ design value of the head pull-through parameter of the screw [N/mm²]

d_h head diameter of the screw [mm]

$f_{tens,k}$ characteristic tensile capacity of the screw according to Annex 2 [N]

γ_{M2} partial factor according to EN 1993-1-1¹⁶ in conjunction with the particular national annex

$k_1 \min \{1; 220/t_{HI}\}$

$k_2 \min \{1; \sigma_{10\%}/0.12\}$

t_{HI} thickness of the thermal insulation material [mm]

$\sigma_{10\%}$ compressive stress of the thermal insulation material under 10% deformation [N/mm²]

If equation (C.10) is fulfilled, the deflection of the battens does not need to be considered when designing the load carrying capacity of the screws.

¹⁶ EN 1993-1-1:2013/a1:2014: Eurocode 3: Design of steel structures - Part 1-1: General rules and rules for buildings

TEX screws	Annex C4
Fastening of thermal insulation material on top of rafters	
Design of the screws	

English translation prepared by IETcc

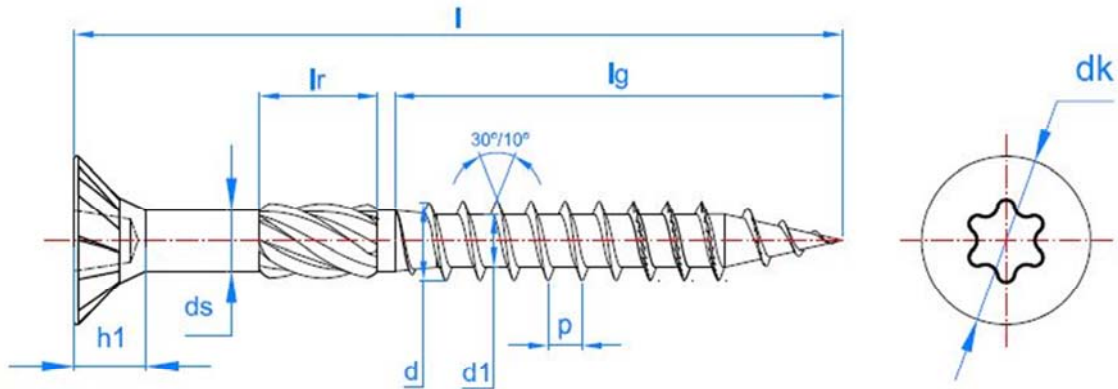

Parameter	Dia 6	Dia 8	Dia 10
d	5.8 ÷ 6.30	7.80 ÷ 8.30	9.70 ÷ 10.20
d ₁	3.80 ÷ 4.10	5.40 ÷ 5.70	6.30 ÷ 6.60
d _s	4.35 ÷ 4.45	5.75 ÷ 5.85	6.95 ÷ 7.10
p	4.14 ÷ 5.06	5.58 ÷ 6.82	6.12 ÷ 7.48
L _r	6 ÷ 8	11 ÷ 13	11 ÷ 13
h ₁	5.57 ÷ 5.87	7.10 ÷ 7.40	8.85 ÷ 9.15
d _k	11.40 ÷ 11.80	14.20 ÷ 14.80	17.60 ÷ 18.40
Recess	T30	T40	T40

Nominal size	Total length	
	Minimum	Maximum
40	38.5	40
45	43.5	45
50	48.5	50
60	58.5	60
70	68.5	70
80	78.5	80
90	88.5	90
100	98	100
110	108	110
120	118	120
130	128	130
140	138	140
150	148	150

Nominal size	Total length	
	Minimum	Maximum
160	158	160
180	178	180
200	197	200
220	117	220
240	137	240
260	257	260
280	277	280
300	297	300
320	316	320
340	336	340
360	356	360
380	376	380
400	396	400
450	446	450

TEXBT: zinc plated, yellow passivated
TEXZT: zinc plated

TEX screws

Dimensions

TEXBT, TEXZT hexalobular recess screws

Annex D1

English translation prepared by IETcc

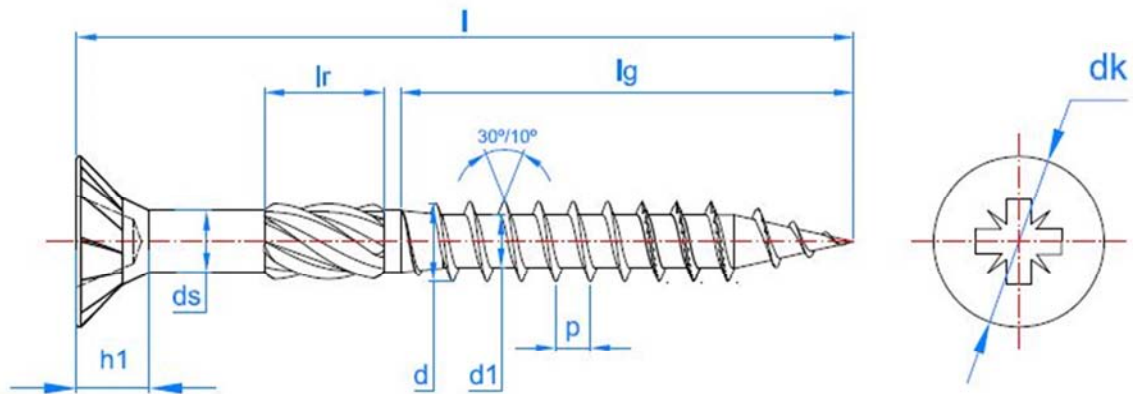

Parameter	Dia 6
d	5.8 ÷ 6.30
d ₁	3.80 ÷ 4.10
d _s	4.35 ÷ 4.45
p	4.14 ÷ 5.06
L _r	6 ÷ 8
h ₁	5.57 ÷ 5.87
d _k	11.40 ÷ 11.80
Recess	PZ3

Nominal size	Total length	
	Minimum	Maximum
40	38.5	40
45	43.5	45
50	48.5	50
60	58.5	60
70	68.5	70
80	78.5	80
90	88.5	90
100	98	100
110	108	110
120	118	120
130	128	130
140	138	140
150	148	150

Nominal size	Total length	
	Minimum	Maximum
160	158	160
180	178	180
200	197	200
220	117	220
240	137	240
260	257	260
280	277	280
300	297	300
320	316	320
340	336	340
360	356	360
380	376	380
400	396	400
450	446	450

TEXBP: zinc plated, yellow passivated
TEXZP: zinc plated

TEX screws

Dimensions

TEXBP, TEXZP Pozidrive recess screws

Annex D2

English translation prepared by IETcc

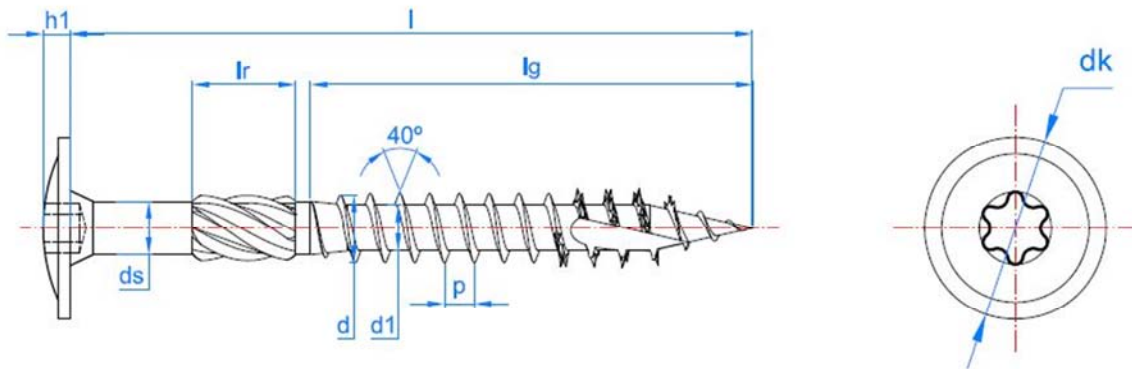

Parameter	Dia 6	Dia 8	Dia 10
d	5.80 ÷ 6.30	7.80 ÷ 8.30	9.70 ÷ 10.20
d ₁	3.80 ÷ 4.10	5.40 ÷ 5.70	6.30 ÷ 6.60
d _s	4.35 ÷ 4.45	5.75 ÷ 5.85	6.95 ÷ 7.10
p	4.60	6.20	6.80
L _r	6 ÷ 8	11 ÷ 13	11 ÷ 13
h ₁	2.65 ÷ 2.95	3.25 ÷ 3.55	3.65 ÷ 3.95
d _k	13.8 ÷ 14.50	20.5 ÷ 21.5	24 ÷ 25.5
Recess	T30	T40	T40

Nominal size	Total length	
	Minimum	Maximum
80	78.5	80
100	98	100
120	118	120
140	138	140
160	158	160
180	178	180
200	197	200
220	117	220
240	137	240
260	257	260
280	277	280
300	297	300

TECBT: zinc plated, yellow passivated

TEX screws

Dimensions

TECBT hexalobular recess screws

Annex D3

English translation prepared by IETcc

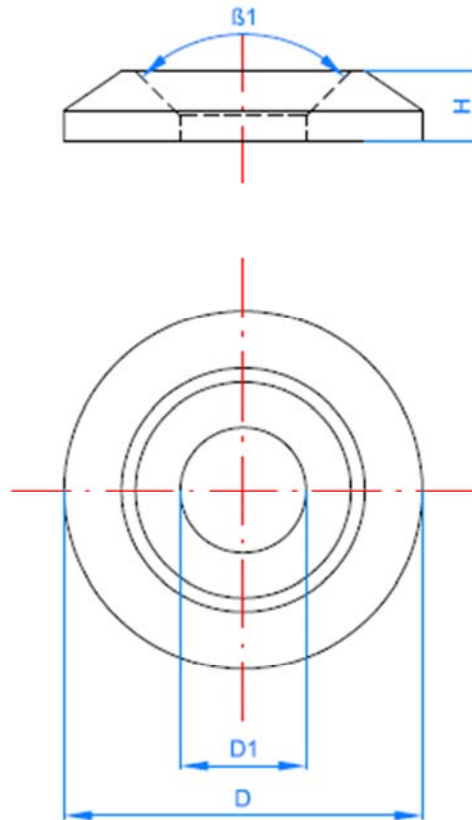

Code	ØD1	ØD	H	β1
TXABM06	7.5 ± 0.3	19.5 ± 0.3	4.6 ± 0.3	90°
TXABM08	8.5 ± 0.3	24.5 ± 0.3	5.4 ± 0.3	90°
TXABM10	10.8 ± 0.3	30.0 ± 0.3	6.4 ± 0.3	90°

TXAB: zinc plated yellow passivated

TEX screws	Annex D4
Dimensions	
Washers	