



**INSTITUTO DE CIENCIAS
DE LA CONSTRUCCIÓN
EDUARDO TORROJA**

C/ Serrano Galvache n. 4 28033 Madrid (Spain)
Tel.: (+34) 91 302 04 40 Fax: (+34) 91 302 07 00
direccion.ietcc@csic.es www.ietcc.csic.es

European Technical Assessment

ETA 16 / 0504 of 21 / 10 /16

English translation prepared by IETcc. Original version in Spanish language

General Part

Technical Assessment Body issuing the ETA designated according to Art. 29 of Regulation (EU) 305/2011:

Instituto de Ciencias de la Construcción Eduardo Torroja (IETcc)

Trade name of the construction product

TP CHC

Product family to which the construction product belongs

Torque controlled expansion anchor made of zinc plated of sizes M6, M8 and M10 for use in precast prestressed hollow core slabs for multiple use in non-structural applications.

Manufacturer

Team Pro International FZCO

Office No LB007002
Jebel Ali, Dubai, United Arab Emirates
website: www.team-pro.info

Manufacturing plant

Team Pro Plant 1

This European Technical Assessment contains

8 pages including 4 annexes which form an integral part of this assessment. **Annex E contains confidential information and is not included in the European Technical Assessment when that assessment is publicly available.**

This European Technical Assessment is issued in accordance with regulation (EU) No 305/2011, on the basis of

Guideline for European Technical Approval ETAG 001 "Metal anchors for use in concrete", ed. April 2013, Parts 1 and 6 used as European Assessment Document (EAD)

Translations of this European Technical Assessment in other languages shall fully correspond to the original issued document and should be identified as such.

This European Technical Assessment may be withdrawn by the issuing Technical Assessment Body, in particular pursuant to information by the Commission according to article 25 paragraph 3 of Regulation (EU) n. 305/2011.

SPECIFIC PART

1. Technical description of the product

The Team Pro TP CHC anchors are made of a metal sleeve and a metal expansion cone. By screwing in a metal normal metric screw with necessary length, not delivered with the product, the expansion cone is pulled into the sleeve. Therefore, the sleeve expands outside the concrete in the hollow area of the hollow prestressed concrete slab. To ensure that the anchor is expanded properly and the expansion cone is pulled into the sleeve sufficient torque moment must be applied on the anchor

The Team Pro TP CHC anchors in the range of M6 to M10 correspond to the pictures and provisions given in annexes A and B. The characteristic material values, dimensions and tolerances of the anchors not indicated in annexes A and B shall correspond to the respective values laid down in the technical documentations⁽¹⁾ of this European Technical Assessment.

For the installation process see figure given in annex C; for the installed anchor see figure given in annex D.

Each sleeve is marked with the identifying mark of the producer, the trade name, the anchor diameter and the metric of bolt required.

The performance of the anchors, including installation data, characteristic anchor values and fire resistance for the design of anchorages is given in chapter 3.

The anchors shall only be packaged and supplied as complete units.

2. Specification of the intended use in accordance with the applicable EAD.

2.1 Intended use

The anchors are intended to be used for anchorages for which requirements for mechanical resistance and stability, safety in case of fire and safety and accessibility in use in the sense of the basic requirements 1, 2 and 4 of Construction Product Regulation no 305/21011 shall be fulfilled and failure of anchorages made with these products would compromise the stability of the works, cause risk to human life and/or lead to considerable economic consequences.

The anchors are to be used only for anchorages subject to static or quasi-static loading in precast prestressed hollow core slabs for multiple use in non-structural applications of concrete of strength class \geq C40/50, according to EN 206.

The anchors may only be used in concrete subject to dry internal conditions.

The anchors may be used for anchorages with requirements related to resistance to fire.

Design under static or quasi-static actions shall be performed in accordance with ETAG 001 annex C or CEN/TS 1992-4-4, design method B. For applications with resistance under fire exposure the anchorages are designed in accordance with method given in TR020 "Evaluation of anchorage in concrete concerning resistance to fire". Anchorages are designed under the responsibility of an engineer experienced in anchorages and concrete work.

(1) The quality plan has been deposited at Instituto de Ciencias de la Construcción Eduardo Torroja and is only made available to the notified bodies involved in the AVCP procedure.

Verifiable calculations and drawings are prepared taking into account of the load to be anchored. The position of the anchor is indicated on the design drawings (e.g. position of the anchor relative to reinforcement or to supports, etc.).

The provisions made in this European Technical Assessment are based on an assumed working life of the anchor of 50 years. The assumed working life is the foreseen period of time throughout which the construction product, as installed into the construction work, will keep its performances allowing the construction work, behaving under predictable actions and with normal maintenance, to meet the basic requirements for construction works.

3. Performance of the product and references to the methods used for its assessment

The identification tests and the assessment for the intended use of this anchor according to the basic work requirements (BWR) were carried out in compliance with the ETAG 001. The characteristics of the components shall correspond to the respective values laid down in the technical documentation of this ETA, checked by IETcc.

3.1 Mechanical resistance and stability (BWR 1)

Mechanical resistance and stability has been assessed according to ETAG 001 “Metal anchors to be used in concrete”, parts 1 and 6.

Installation parameters			Performances		
			M6	M8	M10
d_o	Nominal diameter of drill bit:	[mm]	10	12	16
D	Thread diameter:	[mm]	M6	M8	M10
d_f	Fixture clearance hole diameter:	[mm]	7	9	12
T_{inst}	Installation torque:	[Nm]	10	20	30
h_1	Depth of drilled hole \geq	[mm]	45	50	60
h_{nom}	Overall anchor embedment depth in the base material:	[mm]	38	44	53
l_c	Core distance \geq	[mm]	100	100	100
l_p	Prestressing steel distance \geq	[mm]	100	100	100
a_p	Distance between anchor position and prestressing reinforcement steel \geq	[mm]	50	50	50
l_s	Minimum length of bolt:	[mm]	$t_{fix}+40$	$t_{fix}+46$	$t_{fix}+55$
	Minimum steel class of bolt:		6.8 ISO 898-1		
s_{min}	Minimum spacing:	[mm]	100	100	100
c_{min}	Minimum edge distance:	[mm]	60	70	80

Characteristic values of resistance to loads of design method B			Performances			
			M6	M8	M10	
All load directions						
F_{Rk}^0	Characteristic resistance in \geq C40/50 prestressed hollow core slab:	$d_b \geq 25; < 30$ mm	[kN]	3,5	5,0	8,0
		$d_b \geq 30; < 40$ mm	[kN]	7,0	10,0	10,0
		$d_b \geq 40$ mm	[kN]	8,5	11,5	14,0
γ_M	Partial safety factor: ¹⁾		[-]	1,8	1,5	1,8
s_{cr}	Characteristic spacing:		[mm]	200	200	200
c_{cr}	Characteristic edge distance:		[mm]	100	100	100
Shear load with lever arm						
$M_{Rk,s}^0$	Characteristic bending moment, steel class 6.8:		[Nm]	9,1	22,5	44,9
γ_{Ms}	Partial safety factor: ¹⁾		[-]	1,25	1,25	1,25
$M_{Rk,s}^0$	Characteristic bending moment, steel class 8.8:		[Nm]	12,2	30,0	59,9
γ_{Ms}	Partial safety factor: ¹⁾		[-]	1,25	1,25	1,25

1) In absence of other national regulations

3.2 Safety in case of fire (BWR 2)

Reaction to fire has been assessed according to Commission Decision 96/603/EC, amended by 2000/605/EC. See class in table below:

Reaction to fire	M6	M8	M10
Reaction to fire: [-]	Class A1		

Resistance to fire has been assessed according to Technical Report 020: "Evaluation of anchorages in concrete concerning resistance to fire"

Characteristic resistance under fire exposure in \geq C40/50 prestressed hollow core slabs for use in non structural applications in concrete		Performances		
		M6	M8	M10
d_b	Minimum slab bottom thickness for fire resistance: [mm]	30	30	40
Any load direction				
R30	Characteristic resistance $F_{Rk,fi30}^0$: [kN]	0,20	0,37	0,87
R60	Characteristic resistance $F_{Rk,fi60}^0$: [kN]	0,18	0,33	0,75
R90	Characteristic resistance $F_{Rk,fi90}^0$: [kN]	0,14	0,26	0,58
R120	Characteristic resistance $F_{Rk,fi120}^0$: [kN]	0,10	0,18	0,46
R30 to	Spacing $s_{cr,fi}$: [mm]	160	160	160
R120	Edge distance $c_{cr,fi}$: [mm]	80	80	80
Shear load with lever arm				
R30	Characteristic bending moment $M_{Rk,s,fi30}^0$: [Nm]	0,15	0,38	1,12
R60	Characteristic bending moment $M_{Rk,s,fi60}^0$: [Nm]	0,14	0,34	0,97
R90	Characteristic bending moment $M_{Rk,s,fi90}^0$: [Nm]	0,11	0,26	0,75
R120	Characteristic bending moment $M_{Rk,s,fi120}^0$: [Nm]	0,08	0,19	0,60

- 1) In absence of other national regulations the partial safety factor for resistance under fire exposure $\gamma_{M,fi} = 1,0$ is recommended. Design under fire exposure is according to the design method given in TR020. The design equations are given in TR020, section 2.2.1.
TR020 covers the design for fire exposure from one side. If fire attack is from more than one side, the design method may be taken if edge distance of the anchor is $c \geq 300$ mm.

3.3 Hygiene, health and the environment (BWR 3)

This requirement is not relevant for the anchors.

3.4 Safety in use (BWR 4)

Requirements with respect to the safety in use are not included in this Essential Requirement but are treated under the Essential Requirement Mechanical Resistance and Stability (see section 3.1).

3.5 Protection against noise (BWR 5)

This requirement is not relevant for the anchors.

3.6 Energy economy and heat retention (BWR 6)

This requirement is not relevant for the anchors.

3.7 Sustainable use of natural resources (BWR 7)

No Performance Determined.

4. System of assessment and verification of constancy of performance

According to the decision 97/161/EC of the European Commission ⁽²⁾ the system of assessment and verification of constancy of performance (see Annex V to Regulation (EU) No 305/2011) given in the following table applies:

Product	Intended use	Level or class	System
Metal anchors for use in concrete (light-duty type).	For use in redundant systems for fixing and/or supporting to concrete elements such as lightweight suspended ceilings, as well as installation.	--	2+

5. Technical details necessary for the implementation of the AVCP system, as provided for in the applicable EAD

Technical details necessary for the implementation of the AVCP system are laid down in the quality plan deposited at Instituto de Ciencias de la Construcción Eduardo Torroja.



Instituto de ciencias de la construcción Eduardo Torroja
CONSEJO SUPERIOR DE INVESTIGACIONES CIENTÍFICAS

C/ Serrano Galvache n.º 4. 28033 Madrid.
Tel: (+34) 91 302 04 40 Fax. (+34) 91 302 07 00

www.ietcc.csic.es



On behalf of the Instituto de Ciencias de la Construcción Eduardo Torroja
Madrid, 21st of October 2016

Marta Mª Castellote Armero
Director

(2) Published in the Official Journal of the European Union (OJEU) L62/41 of 4.3.1997 See www.new.eur-lex.europa.eu/oj/direct-access.html

INDEX OF ANNEXES:

Annex A: Assembled anchor

Annex B. Materials

Annex C. Installation process

Annex D. Schema of the anchor in use

Annex A: Assembled anchor

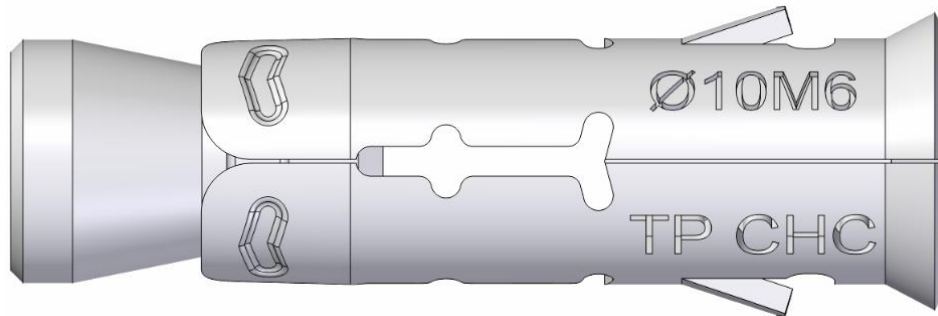

Identification on anchor:

- Expansion sleeve:
 - Outer diameter, metric
 - Anchor trade name. "TP CHC"
 - Company logo

Annex B. Materials

Item	TP CHC anchor
Expansion sleeve	Carbon steel strip, electro zinc plated $\geq 5 \mu\text{m}$ ISO 4042 A2
Cone	Carbon steel wire rod, electro zinc plated $\geq 5 \mu\text{m}$ ISO 4042 A2

Annex C. Installation process

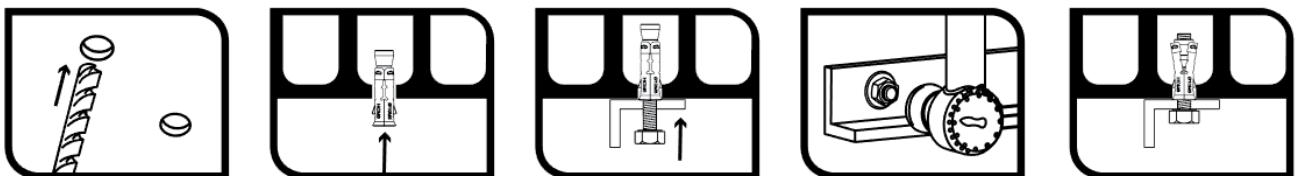

Annex D. Schema of the anchor in use

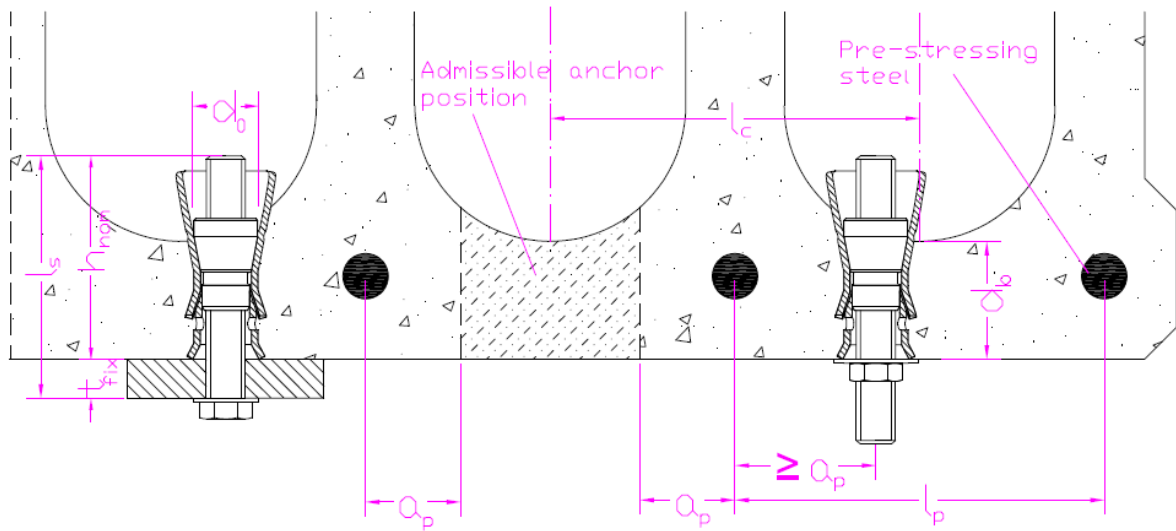

- h_{nom} : Overall anchor embedment depth in the base material
- d_0 : Nominal diameter of drill bit
- d_b : Minimum thickness of prestressed hollow core concrete slab
- t_{fix} : Thickness of fixture
- l_s : Overall length of bolt
- l_c : Core distance
- l_p : Prestressing steel distance
- a_p : Distance between anchor position and prestressing steel